

Chapter 1

Introduction

This chapter discusses the motivation for the research described in this thesis. The research methodology is presented, followed by a literature review. Finally, an outline of the thesis is given along with a list of original contributions.

1.1 Motivation

The quest to improve the dynamic performance, the operating efficiency, and the amount of material that is used in systems that employ mechanical structures, has prompted many designers to employ lightweight materials and to reduce the cross sectional dimensions of those structures. The benefits of using lightweight materials and reduced cross sectional dimensions include: reduced weight, decreased wind resistance, reduced energy requirements, increased acceleration, and a decreased in the physical space requirements. Some practical outcomes resulting from these benefits include: the enhanced manoeuvrability of robotic arms, the increased range of aircraft, and the reduced fuel consumption of vehicles.

However, one side-effect of employing lightweight materials and reducing the cross sectional dimensions is that the structures become more flexible. Flexible structures are more susceptible to the detrimental effects of unwanted vibration, particularly when they operate at or near their natural frequencies or when they

are excited by disturbances that coincide with their natural frequencies.

The enhanced vibration of a structure subjected to an oscillating force close to a natural frequency of the structure is known as resonance. For many structures, operating at or near resonance is undesirable because it can degrade performance, reduce lifetime, and even lead to rapid destruction. A paradigm for this behaviour is the failure of the Tacoma Narrows Bridge in 1940. The shallow and narrow span of the bridge made it flexible and the deck of the bridge acted like an aircraft wing in uncontrolled turbulence when it was subjected to an unpredicted wind pattern [109]. This one example shows how important it is to attenuate or control the vibration in flexible structures, especially those that occur at or near resonance.



Figure 1.1: The twisted roadway of the Tacoma Narrows Bridge before its failure.

Rather than sacrifice the gains to be made by reducing the mass of structures, interest has centred on means of reducing vibration when it occurs. Particular emphasis has been placed on active control, in which anti-phase excitation is introduced in order to destructively interfere with vibration frequencies.

The design and implementation of a high performance vibration controller for

a flexible structure can be a difficult task. The difficulty is due to the following factors:

1. The order of a flexible structure can be very large and mostly unknown [52]. Structures with large orders have many modes of vibration and controlling all of the modes is, in practice, impossible. Therefore, controllers are usually designed to attenuate only the most significant or dominant vibration modes. In the design of a system that consists of a controller and a flexible structure, it is common practice to approximate the actual flexible structure with a low order approximation model [96]. This approximation is achieved by removing all the modes that lie outside the bandwidth of interest. However, the use of a low order approximation model can cause system uncertainties due to unmodeled dynamics. These unmodeled dynamics can lead to system instability due to spillover, which is any unwanted vibration associated with other modes. There are two types of spillover: control spillover and observation spillover. Control spillover occurs when the control force excites unmodeled dynamics. The excitation of these unmodeled dynamics can degrade the performance of the system. Observation spillover refers to the measurement error caused by the contribution of excluded modes to the sensor measurements. While control spillover leads to poor performance, observation spillover can lead to instability, as shown in the numerical simulation by Balas [8].
2. To control a flexible structure that has widely separated multi-mode vibration a wide-band controller is needed. However, the design of a high performance wide-band controller is difficult. The difficulty is due to the design trade-off between the error reduction in one frequency band and the increase of sensitivity at other frequencies, as explained in Bode's theorem [94]. That is, a wide-band controller is necessary to cover all the modes

of interest, but a narrow-band controller is required to achieve good attenuation of a certain mode, without having a negative effect on the other modes.

3. In many applications, the parameters of systems with flexible structures are not fixed. The parameters can be time varying with different variations in characteristics. The variations can be relatively small and continuous, such as in the reduction of the total mass of aeroplane due to its fuel consumption, or sudden and large, such as when an aircraft releases a missile, or when a robot arm picks up or drops a heavy object. For some applications, the variations are not *a priori* known, e.g., a robot arm collecting samples of unknown mass or being subjected to unforeseen environmental disturbances. For these kinds of applications the difficulty associated with the design of controllers is even greater. A fixed-parameter controller might be able to achieve stability, but the capability of this type of controller in dealing with system uncertainty is limited [152]. Fixed-parameter controllers usually give poor performance or even become unstable when the parameters are extended to values beyond the limits of the initial design.

These factors assist designers in determining the essential requirements of a vibration controller for flexible structures. To retain the high-speed performance of the flexible structures the transient response of the closed-loop system needs to be fast with respect to the rate of change of the system's states. Furthermore, a controller must be able to give optimum attenuation to unwanted vibration regardless of any system uncertainties, such as those caused by variations to the system parameters or by the unmodeled dynamics due to mode truncation. Moreover, the controllers must be able to effectively attenuate vibration modes of interest without introducing spillover. Other desirable requirements include, employing a minimum number of sensor-actuator pairs, using a simple design

structure, and imposing a minimal computational load when processing real-time applications.

Given these requirements, the question is how to design and implement a suitable controller. Seeking the answer to this questions is the motivation for the research described in this thesis.

1.2 Research Methodology

The research methodology consists of four steps. In the first step, a literature review overviews the relevant existing methods for controlling the vibration of flexible structures, and discusses the relevant shortcomings or gaps in those methods. Based on the gaps that are found in the existing methods, new control methods are proposed. The first method that is proposed, is relatively simple that works well under very tight assumptions. This is followed by proposals for relatively complex methods that allow the assumptions to be relaxed, and therefore with wider applications.

In the second step, an experimental plant that can be used as a tool for the design and evaluation of the effectiveness of the proposed control methods, is designed and implemented. The plant chosen must represent a real application and have the essential characteristics of a flexible structure. A flexible cantilever beam with magnetically clamped loads located at arbitrary positions along the beam is chosen as the experimental plant. The reasons for choosing this structure are:

1. A cantilever beam with relatively heavy loads mounted along the length of the beam is widely used as a basic model for a number of flexible advanced engineering structures such as robot arms or aircraft wings [137, 138].
2. This structure has well- separated multi-mode vibration. The frequency of

the first mode is separated by more than one decade from its corresponding third mode frequency.

3. This structure can exhibit large and sudden changes to its natural frequencies by dropping the load(s).

From the above reasons it can be seen that a cantilever beam can be used to represent real applications and that the chosen cantilever beam has the required characteristics of a testbed that can be used for the design and evaluation of the proposed control methods.

In the third step, simulation models of the experimental plant are implemented, and computer simulations are exercised. These simulations reduce the design time, increase the success rate of the real-time implementation, and help in the evaluation of the performances of the proposed controllers prior to their use with the experimental plant.

In the fourth step, the proposed controllers are used with the experimental plant and the effectiveness of the proposed control methods are evaluated.

1.3 Control of Vibration

Vibration control can be categorized into two major techniques: passive control and active control.

Passive Control

With passive control, vibration is attenuated or absorbed by passive components such as vibration dampers and dynamic absorbers that use mass-spring-damper decoupling. This technique is conventional and well developed [120]. However, it has two major drawbacks. Firstly, it is ineffective at low frequencies. The natural frequency is inversely proportional to the square root of the spring compliance

and to the mass of the damper. Hence, at low frequencies, the volume and mass requirements are often impractically large for many applications where physical space and mass loading are critical [53, 93]. Secondly, the passive technique only works effectively for a narrow band of frequencies and is not easy to modify. The passive components are sensitive to the characteristics of the structures (i.e., damping factors and natural frequencies) and to the sources of vibration. A redesign of the components is usually needed when the characteristics of the structures or the sources of vibration are changed.

Active Control

With active control an electronic controller sends command signals to actuator(s) such as electromagnetic shakers, piezoelectric ceramics and films, or magnetostrictive devices to generate a secondary vibrational response. This secondary response can reduce the overall response by destructively interfering with the response of the system due to the primary source of vibration. In contrast with passive control, active control works effectively over a wide bandwidth where the working band does not depend on the characteristics of the structure, and is limited only by the bandwidth of the actuators. Furthermore, the actuators are less sensitive to the characteristics of the structures and the vibration sources. Therefore, the same actuators can be used even if the characteristics of the structures or the vibration sources are changed. To maintain the system performance, the electronic controller might need to be modified, but this modification is relatively easy, especially with digital controllers.

From this discussion, it is clear that passive control is not suitable for controlling flexible structures with varying parameters. On the other hand, active control shows good potential. This thesis focuses on the design of active controllers.

1.4 Active Vibration Control

1.4.1 Feedforward and Feedback Control

Active control can be classified as feedforward or feedback control depending on the derivation of the error signal.

Feedforward Control

The design of feedforward control is based on the assumption that a reference signal representing the primary excitation is available or that the primary excitation to the structure can be directly observed. This approach has a very attractive feature because if the reference signal and the primary excitation are exactly the same, it is theoretically possible to achieve exact cancellation of the vibration [45]. Another advantage of this approach is that the overall system is always stable since this approach does not modify the characteristics of the original plant. However, in many cases such as in the attenuation of the resonant response of an impulsively excited structure or in the attenuation of vibration in a structure with sudden parameter changes, a suitable reference signal may not be available. Therefore, the only possible way to control vibration in such cases is to employ feedback control [45].

Feedback Control

In feedback control, the error signal, which is the difference between the desired response and the controlled output, is fed to the controller. The controller then generates control signals to drive the error signal to zero. With feedback control, stability becomes a major concern because the feedback modifies the characteristic of the original plant.

Due to the variations of the system parameters and the excitation signal in the flexible cantilever beam with varying load conditions, feedforward control is not suitable for application with this system. Therefore, the design control method

discussed in this thesis focuses on feedback control.

1.4.2 Wave Control and Modal Control

Active control can also be classified according to the model descriptions upon which the control design is based. The most common descriptions of the vibration of continuous systems are in terms of waves and modes of motion [35]. These two descriptions lead to two different approaches for active control: wave control and modal control. The first concentrates on controlling the flow of vibrational energy through a structure, while the second focuses on controlling the modes of the structure.

Wave Control

In a structure where the flow of vibrational energy from one part to another is significant and needs to be reduced, wave control is normally used. Wave control design makes use of the wave equation of a structure and the local properties at and around the control region. Since inherently the local properties of the structure are less sensitive to system properties wave control has a good robustness. However, because it does not take into account global motion, global behaviour can adversely affect the amount of control achieved.

When implementing wave control, to achieve good performance over a large area of a structure, large numbers of sensors in the form of a sensor array, are required [44, 57, 131]. Therefore, one of the desirable design requirements, stated earlier, namely employing a minimum number of sensor-actuator pairs, cannot be achieved if wave control is used. Moreover, most implementations of wave control are of the feedforward type [19, 24, 44, 57, 89, 131]. For these reasons, no further discussion or investigation of wave control is considered.

Modal Control

For a control system where the objective is to attenuate the overall structural

vibration, modal control is usually employed [45]. In modal control theory, the structure's dynamics are broken up into a series of decoupled second-order ordinary differential equations (ODE) through coordinate transformation. Each second-order ODE is similar to a single-degree-of-freedom (SDOF) system, thus making it easy to analyse. This transformation also draws upon physical intuition and insight gained from the experience of modal analysis which is well developed. Since the modal properties (i.e., damping factors, natural frequencies and mode shapes) depend on the global properties of the structure, and since by reducing the amplitudes of the structural modes the space average mean square velocity over the whole structure is reduced, modal control is said to be a global control method [89, 35]. As a natural consequence of its global nature, modal control may suffer from spillover.

1.5 Modal Based Controllers for Multi-mode Vibration Control

The main modal control methods that can be found in the literature for controlling multi-mode vibration in flexible structures include: independent modal space control (IMSC) [90], positive position feedback (PPF) control [37], and resonant control [43, 113, 114].

The IMSC method controls each mode separately in order to evade the spillover problem. The modal control for each mode uses only the respective displacement and velocity feedback for the corresponding mode to avoid the coupling of modal equations. Independent displacement and velocity gains are selected as modal gains for each mode. Therefore, an independent controller can be designed for each mode of vibration. The control gain for each mode can be found from solving a second-order Riccati equation from optimal control theory by minimizing a quadratic performance index J which is the sum of the potential energy and

kinetic energy of the vibrating system. IMSC, however, has a significant disadvantage in that each mode requires its own sensor-actuator pair [54]. In order to control multi-mode vibration using a single sensor-actuator pair, Baz *et al.* [12, 13] developed a time-sharing technique, referred to as modified independent modal space control, whereby each mode of vibration is separately controlled according to the mode's energy. At periodic intervals, the energy in each mode is calculated and the mode with the highest energy is controlled. Once the controlled mode has settled and the energy in another mode becomes dominant, the control effort is redirected to that mode. This method, however, has a high computational load, which is caused by the need to calculate and compare the energies in all modes of interest at every time interval.

The PPF method was proposed by Goh and Caughey [37] to avoid the spillover problem. A special second-order compensator is designed such that its gain drops sharply at high frequencies so as to avoid exciting residual modes. An example of a PPF application used to control multi-mode vibration with only a single sensor-actuator pair is shown in [132]. Here the PPF controls slewing and vibration of a single-link flexible manipulator with two dominant modes. Two parallel PPF controllers are employed to cancel the first two modes. Each controller parameters are based on the corresponding natural frequency of the mode for which it is designed. To test the performance of the controlled system subjected to parameter changes, the actuator position is shifted from the original position to make the natural frequencies change from the original frequencies. Experimental results show that PPF is insensitive to parameter changes but still gives reasonable attenuation. Although PPF does not introduce spillover, it does, however, possess a drawback that could affect its suitability for multi-mode applications. The phase of the PPF compensator tends to 0 for vibration frequencies below the targeted mode and π for frequencies above. Hence, for a single-mode controller the effective structural flexibility below the targeted mode is increased.

This will in turn lead to larger steady-state errors [136]. This problem becomes compounded when using parallel PPF compensators to handle multiple modes since the modal gain of each compensator is not independent and the higher mode compensators may adversely affect the attenuation of the lower modes [34]. Consequently, the attenuation of the lower modes with a multi-mode compensator is compromised thus rendering the PPF compensator structure unsuitable for the overall attenuation of multiple modes.

The Resonant Control method proposed by Pota *et al.* [113] is based on the resonant characteristic of flexible structures. The controller applies high gain at the natural frequency and rolls off quickly away from the natural frequency thus avoiding spillover. It is also described as having a decentralized characteristic from a modal control perspective [43], thereby making it possible to treat each of the system's modes in isolation. Hence, in contrast to PPF, the gain selection for each mode of the resonant controller is independent, which enables the design of the multi-mode controller to be as simple as that of the single-mode controller. Other advantages of this controller are that it is able to control multi-mode vibration using only a single collocated sensor-actuator pair, and that its design is based only on the structure natural frequencies thus resulting in a minimal computational load suitable for real-time implementation.

The characteristics of resonant control meet the design requirements set at the beginning of this chapter. The control method is simple with only one design parameter. It is robust to unmodeled dynamics that can cause spillover, and it is capable of suppressing multi-mode vibration using a single sensor-actuator pair. Based on these characteristics, the resonant control will be used as a basis for controller design. However, the frequency-sensitivity characteristic of the resonant controller is a limitation if the structure natural frequencies are altered by changes in its configuration and/or loading. Therefore, to enable the resonant

controller to cope with the system uncertainties, modifications or extensions of the controller are also investigated.

1.6 Control Methods for Systems with Varying Parameters

Two basic methods that can be found in the literature for controlling systems with varying parameters are: gain-scheduling control [14, 25, 60, 72, 116, 143] and multiple model control (MMC) [5, 6, 22, 38, 40, 48, 110, 75].

Gain-Scheduling Control

Gain-scheduling control is one of the most commonly applied techniques for controlling variable parameter systems, especially where the dynamic behaviour of the systems change with the operating conditions [1, 14, 25, 72]. The reason that gain-scheduling is so commonly adopted is that this method offers some practical advantages such as simple design and low computational load. The gain-scheduling method is based on the assumption that there exists a rigid relationship between the measurable variables, known as auxiliary variables, that characterize the system's environment and the operating conditions, and the parameters of the system. The principle of gain-scheduling is to change or schedule the parameters of the controller as functions of the auxiliary or scheduling variables, as shown in Fig. 1.2 [1]. From the figure, gain-scheduling can be viewed as a feedback control system in which the feedback gains are adjusted using feedforward compensation [1]. The adjustment of the controller gains is precomputed off-line and, therefore, provides no feedback to compensate for incorrect schedules [56]. This is one of the disadvantages of the gain-scheduling control, where unpredictable changes in the plant's dynamics may lead to deterioration of performance or even to complete failure.

Another drawback of gain-scheduling is assuming the availability of the aux-

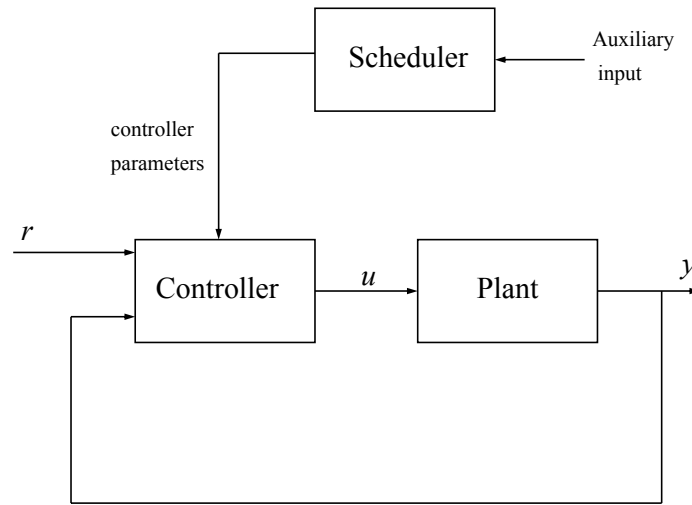

Figure 1.2. Block diagram of gain scheduling control.

iliary variables. Gain-scheduling control is not appropriate for a system with no direct correlation between the measurable variables and the system parameters. For the multi-mode vibration of a flexible beam with varying load conditions, simple correlations between measurable variables such as position, velocity, displacement or frequency with the current loading conditions or parameters of the system do not exist. All the measurable variables are dependent not only on the current loading condition but also on the external disturbance. Therefore, gain-scheduling control method is not suitable for controlling multi-mode vibration in a flexible structure with varying loading conditions.

Multiple Model Control

In contrast to gain-scheduling control, multiple model control (MMC) does not need auxiliary variables for its operation. In MMC, a set of model-controller pairs, referred to as model bank and controller bank, is designed. The design of the models in the model bank is based on the *a priori* knowledge of the plant. Several models are provided to cover the various plant conditions that may exist between the upper and lower bounds of the plant. It is assumed that at least one model or

a weighted combination of models in the model bank will be close enough to the current plant condition. Corresponding to each model, a controller is designed to achieve desired performance. A supervisor or a weighting function is used to choose a single model or a combination of models as the best representation of the current plant condition. Two methods to determine the criteria for the best representation of the current plant condition are found in the literature [5, 6, 22, 38, 40, 48, 64, 75, 101]. The first method is based on the similarity of the models to the current plant. In this method, a probability estimate using Bayes' rule is commonly used [5, 22, 40, 48]. The second method is based on the error tracking on the time horizon. In this method, the minimum mean-squares error algorithm is commonly used [38, 64, 75, 101].

A shortcoming of the MMC is the high computational load requirement. Intensive computations are necessary to solve Bayes' rule or the minimum mean-squares algorithm in the supervisor or weighting function scheme. The computational load also increases with the number of models in the model bank. MMC with its existing supervisor or weighting function scheme requires a powerful processor for real-time implementation and it may be impractical to implement if the number of models is large. To overcome this shortcoming, a simple supervisor scheme can be designed based on the selective attenuation characteristic of resonant control so that a less powerful processor can be used.

The prior knowledge assumption used in the MMC method is satisfied if all the loading conditions are *a priori* known. If, however, loading and environmental conditions cannot be previously predicted then alternative methods, which specifically deal with uncertain systems, are required.

1.7 Control Methods for Systems with Uncertainties

The flexible beam with its varying loading conditions being used as the experimental plant in this research has large uncertainties. The uncertainties are due to the variation in the loading conditions and the unmodeled dynamics due to truncation in the modeling process. There are two major control methods for dealing with systems with uncertainties [41, 108, 154, 158]: robust control and adaptive control.

1.7.1 Robust Control

Robust control uses a design method which focuses on the robustness of the control algorithm. In this approach, the controller is designed to withstand certain degrees of bounded uncertainties caused by non-linearity, modeling errors or exogenous disturbances. The design typically requires that the uncertainties be bounded in a specific region [118]. Therefore, it is important to know the parameters' boundaries before designing a robust control. Once the controller is designed, its parameters do not change and control performance is guaranteed within the designed region.

There are two main design approaches in robust control: H_∞ control and Lyapunov's stability direct method. In a H_∞ controller, robustness is achieved using a state feedback control law that minimizes the supremum norm of the transfer function from the disturbance input to the system's output [79, 97]. In Lyapunov's stability direct method, robustness is maintained via the use of a control law in which the Lyapunov function decreases along a trajectory. This is based on the principle that a dynamic system will settle down at its equilibrium point if the system's total energy decreases [67].

In general, robust control is suitable for dealing with small uncertainties

[152, 154, 158]. However robust control cannot give satisfactory performance when applied to a control system with large uncertainties. For this kind of a system, the amount of uncertainty is too large to compensate for using a fixed-parameter controller. Furthermore, the response at some operating points may have to be overly conservative in order to satisfy specifications at other operating points, while the controlled process itself varies significantly during operation [157]. Because robust control is not suitable for the control of flexible structures with large uncertainty it will not be considered any further.

1.7.2 Adaptive Control

In contrast to the robust control approach, the adaptive control approach uses an on-line identification technique to estimate the current plant parameters. Its distinctive feature is that it consists of a tuneable controller and an identifying mechanism (an estimator). Sastry and Bodson [129] define adaptive control as a direct aggregation of a (non-adaptive) control methodology with some form of recursive system identification.

Based on how the estimator is combined with the controller, adaptive control is divided into two different approaches: indirect adaptive control and direct adaptive control.

Indirect Adaptive Control

In indirect adaptive control it is assumed that a model of the plant is available through on-line estimation, so that the controller parameters can be up-dated on-line. In principle, one can combine any parameter estimation scheme with any control method to form an indirect adaptive control. The algorithm used in this approach can be described in two steps. The first step is to estimate the parameters of the plant, and the second step is to determine the controller parameters based on the estimated parameters from the first step. This approach is based

on the certainty equivalence principle [1]. Using this principle, the controller parameters are computed by assuming that the current plant model parameter estimations are equal to the real one. The most popular implementation of

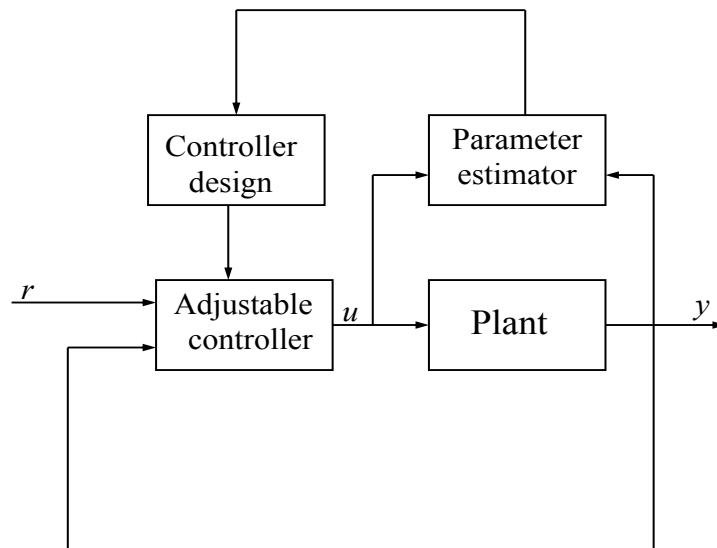

Figure 1.3. Block diagram of the Self Tuning Regulator scheme.

indirect adaptive control is the Self Tuning Regulator (STR) scheme which is illustrated in Fig. 1.3.

Direct Adaptive Control

In direct adaptive control, it is assumed that there exists a parameterization of the controller such that the closed-loop system behaves in the desired fashion. Therefore, the parameters which need to be identified are the controller parameters. Direct adaptive control usually has the disadvantage that all process zeros are cancelled [150]. This implies that direct adaptive control is intended only for plants with a stable inverse or minimum phase systems, where the cancellation of all the process zeros is guaranteed. Direct adaptive control is usually implemented in a Model Reference Adaptive System (MRAS) scheme, as shown in Fig. 1.4.

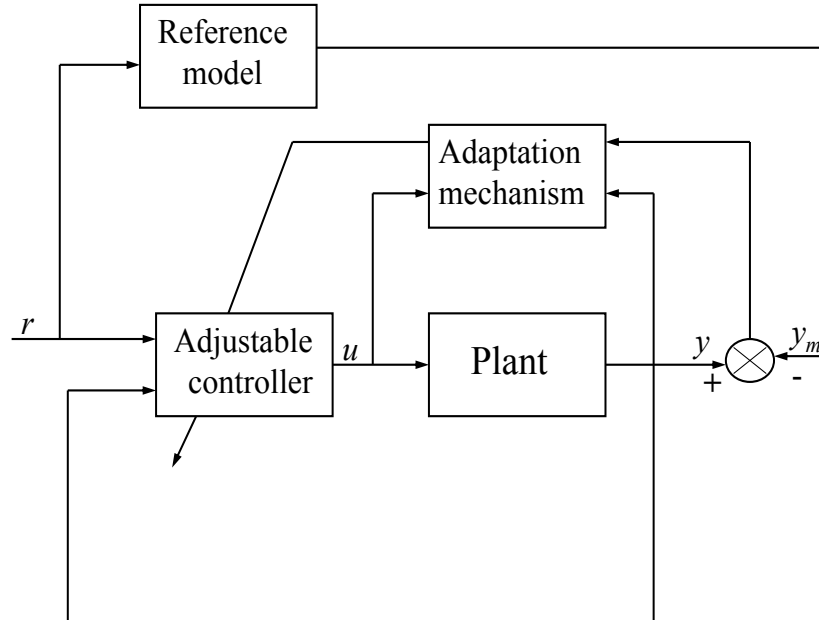

Figure 1.4: Block diagram of Model Reference Adaptive System scheme.

Since the on-line parameter estimator used in adaptive control will track the changes to the plant parameters and produce new parameters for the controller, the adaptive control approach is applicable to systems with large parameter variations.

In the field of vibration control, numerous applications of adaptive control are found in the literature. Wherein the adaptive control is applied to systems subjected to varying disturbances [4, 16, 49, 69, 87, 112, 133, 134, 144] and to systems with varying parameters [7, 11, 50, 51, 121, 125, 141]. For systems subjected to varying disturbances, the estimator is used to estimate and/or track the variations of disturbances. The estimation results are then used to update the adaptive controller parameters so that optimum attenuation is achieved. Several estimation methods such as zero crossing [4], gradient descent [49, 55], phase-locked-loop (PLL) [16], least-mean-squares [112], and recursive-

least-squares (RLS) [69, 87, 133, 134, 144] are commonly used to estimate the disturbances. For systems with varying parameters, the estimator is used to estimate or track parameters changes. The most commonly used estimation method for estimating the parameters of a system is the RLS [7, 51, 121, 125, 141]. Compared to robust control, adaptive control possesses two distinctive advantageous features. Firstly, adaptive control is capable of dealing with large and sudden changes to a system parameters. Secondly, adaptive control is compatible with any standard controller design method. It is relative easy to modify or convert any standard control method into an adaptive controller. Because of these two features adaptive resonant control methods are included in this research.

1.8 Natural Frequency Estimator

One simple technique that is used to make a resonant controller adaptive is to use a zero-crossing method to measure the vibrating structure's frequency [3, 4]. However, this method only works effectively when the structure is subjected to a single frequency excitation. For a broadband disturbance, which includes multiple frequencies that match the structure natural frequencies, the zero-crossing method is unable to identify any of the natural frequencies. Consequently, the controller will be unable to attenuate the corresponding resonant vibration. Thus, for multiple-frequency excitation, an effective natural frequency estimation method is required.

With adaptive control, the computational efficiency and convergence rate of the natural frequency estimator are as critical as the estimator's ability to produce accurate estimations of the system natural frequencies. The non-parametric frequency estimation approach that is based on the computationally intensive Fast Fourier Transform [145, 124] is therefore not suitable for adaptive control methods. Rew *et al.* [122] surveyed the parametric frequency estimation approach

and developed a real-time natural frequency estimator based on the Recursive Least-Squares (RLS) method combined with the Bairstow method. The results from that paper show that for multi-mode frequency estimation, the estimator is sensitive to sampling rate selection and to unmodeled high frequency modes. The estimator will fail to give reasonable estimations for the lower modes if the sampling rate is too high relative to the natural frequencies of those modes. For a system with resonant modes that are spaced more than a decade apart in frequency, a sampling rate that suitable for one mode will be too high for the lower modes, thus the estimator cannot give reasonable results. The word length limitation in the digital implementation also contributes to inaccuracy in the estimation, especially for high sampling rates and high order implementations, as shown in [9, 117]. Furthermore, as discussed by Wahlberg and Ljung [148], frequency domain analysis shows that the least-squares method has a tendency to emphasize high frequencies, especially at high sampling rates. This analysis led designers to use prefiltering to remove frequencies above the highest mode of interest in order to improve the estimation accuracy [20, 125, 126]. However, although Rovner and Franklin [126] show that prefiltering improves the estimation accuracy, particularly for the highest modes, the estimator's high-pass filter characteristic still produces inaccurate results for the lower modes.

As part of this research, an adaptive resonant controller for the control of multi-mode vibration in a flexible beam with varying load conditions is designed. To achieve the desired requirements set out at the beginning of the thesis, a natural frequency estimator, that can accurately estimate system natural frequencies when the resonant modes are spaced more than a decade apart in frequency, is required. To design an accurate estimator, the sampling rate selection, the prefiltering components, and the determination of the estimator order must be included in the design considerations.

1.9 Multiple Model Adaptive Control

Due to the on-line estimation process, an adaptive controller inherently has a relatively slow transient performance compared to a fixed-parameter controller [30, 41, 50, 157]. For a large and sudden change in the system parameters, adaptive control might produce a large transient performance. For certain systems with strict operational requirements such as an aircraft, a large transient performance may be unacceptable. Consequently, it is necessary to improve the transient performances of adaptive controllers used in this type of application.

An approach that has been used to improve the transient performances of an adaptive control is to combine adaptive control with MMC, as proposed by Narendra and Balakrishnan [100]. The method is known as multiple model adaptive control (MMAC). In this method, a bank of *a priori* known fixed-parameter models, which represent the possibilities of different conditions, is provided. In addition one or more adaptive models are included in the model bank to add an adaptation capability to the system. A bank of controllers, with each controller associated with a corresponding model in the model bank, is designed to satisfy the control objective. The paired model-controller banks work in parallel. At every instant a supervisor selects the best model based on a certain criterion, and assigns the corresponding controller to be applied to the plant. Concurrently, the adaptive model(s) is fine tuned to bring its parameters closer to the current parameters of the plant so that optimum performance can be achieved. In principle this method uses fixed-parameter models when the adaptive model is still in the transient condition, and switches to the adaptive model once the model has reached its steady-state condition. With the assumption that there is at least one model close enough to the current plant condition each time the system is changed from one condition to another, the transient response of the system is improved.

Along with the MMC method, the main disadvantage of the MMAC method is the high computational demand of the supervisor scheme. The computational demand of the MMAC also increases due to the estimation process of the adaptive models. Therefore, to practically apply the MMAC method a simple supervisor scheme is required.

1.10 Aim of the Thesis

Motivated by the need for a simple high performance controller for suppressing vibration in a dynamically loaded flexible structure, this thesis describes research that is devoted to the investigation and development of active control methods for minimizing multi-mode vibration with varying natural frequencies. The implemented controllers are able to give good performance when subjected to large and sudden changes of the system parameters, but simple enough to implement in a real-time system. A cantilever beam with magnetically clamped loads is chosen as the research vehicle. This cantilever beam is specifically designed to exhibit large variations in natural frequencies and has wide ranging natural frequencies, where the first and the third natural frequencies are separated by more than a decade.

Investigations into three control methods: multi-model multi-mode resonant control (M^4RC), multi-mode adaptive resonant control (ARC) and multi-model multi-mode adaptive resonant control (M^4ARC) are proposed, discussed and evaluated in this thesis.

M^4RC

M^4RC is a multi-model control approach. In this approach it is assumed that all the possible loading conditions for the flexible beam are *a priori* known through a modeling process. From the *a priori* knowledge of the plant, a bank of models is designed such that each model gives optimum attenuation for a particular loading

condition. A simple supervisor scheme, based on the utilization of a filter bank system, is used to determine for each mode which model has the closest frequency to the observed vibration frequency.

ARC

If the assumption, that not all the possible loading conditions are *a priori* known, is relaxed, then it is possible for unknown loading conditions to be encountered by the system. To cope with unknown loading conditions, ARC is proposed to control the system. The proposed ARC uses only the natural frequencies of the system as the design parameter and an on-line natural frequency estimator is proposed to estimate the natural frequencies.

M⁴ARC

Finally, to improve the transient response of the proposed ARC, M⁴ARC is proposed. The M⁴ARC is a combination of the ARC and the M⁴RC. The principle of the M⁴ARC is to use the M⁴RC to deal with the transient conditions and then switch to the ARC once the system's steady-state is reached in order to achieve optimum control during unforeseen loading changes.

1.11 Outline of the Thesis

This thesis presents the design and implementation of the resonant-based controllers for attenuating multi-mode vibration in dynamically loaded flexible structures. A detailed outline of the thesis structure is given below.

In Chapter 2, the experimental plant for validating the proposed controllers is first discussed. The derivation of the mathematical models and the implementation of the corresponding simulation model of the experimental plant are then presented. Since all the proposed controllers are designed using the modal control method, the mathematical models of the beam for different loading conditions

are derived using modal analysis. In many flexible structures, such as beams, the torsional and axial vibration are very small compared to the flexural vibration. Therefore, only the derivations of equations of motions for flexural vibration of a beam with arbitrary loadings along the beam are considered. The mathematical models obtained from the modeling processes are validated by comparing these models with valid models cited in the literature. The models obtained are then compared with the experimental plant and with the numerical models obtained using Finite Element Method software ANSYSTM. The comparisons are used to find out whether the numerical models obtained from ANSYS are accurate enough to be used as models for the design of the controllers. Finally, in order to implement the simulation models of the experimental plant, the transfer function form of the mathematical models are derived using modal analysis in ANSYS. The simulation models are then implemented in SimulinkTM. Details on the derivation of the simulation models and the transfer functions of the models are given in Appendix A.

In Chapter 3, the M⁴RC is proposed to enable the resonant control to cope with the natural frequency variations in a multi-mode system. A brief introduction to resonant control is presented at the beginning of the chapter, followed by a presentation of the controller structure and an analysis of its characteristics. To implement the resonant controller in a real-time micro controller platform, the continuous-time resonant controller is transformed to its corresponding discrete-time version. To preserve the passivity characteristic of the continuous resonant controller, a bilinear transformation method is used as the discretization method. The stability analysis of the discrete time resonant control is then obtained using the passivity theorem. Definitions of passivity in continuous and discrete systems are given in Appendix B. A discussion of the multiple model control approach as the basis of the M⁴RC design is presented prior to describing the M⁴RC design. To test the effectiveness of the proposed method, a series of simulation studies

are conducted, and the results then verified through experimental studies.

In Chapter 4, an on-line natural frequency estimator is proposed to give an adaptation capability to the resonant controller which uses natural frequency as the design parameter. A literature review of the estimation methods used to determine the natural frequencies of flexible structures is given at the beginning of this chapter. The literature review is focused on the shortcomings of the extant methods and the reasons for their shortcomings. A review of the on-line parameter estimation concept and the derivation of the RLS algorithm are given followed by a stability analysis of the RLS algorithm. The effects of the high-pass characteristics of the RLS, the sampling period selection, and the finite word-length limitation on the estimation accuracy of the RLS-based estimator are then analysed. This analysis leads to the proposed method for designing an accurate natural frequency estimator for a flexible structure. Simulation and experimental studies are then used to evaluate the performance of the proposed estimator.

In Chapter 5, the ARC and the M⁴ARC are proposed. The chapter starts with a brief review of adaptive control transient response and the MMAC method. Due to the simple characteristics of resonant control, the proposed ARC uses only the natural frequencies as the adaptation parameter. Since the controller is formed in an indirect method, the stability analysis of the controller can be given by analysing the stability of the estimator and the stability of the controller separately. To improve the transient response of the adaptive resonant controller, a modification of the MMAC concept is applied to form M⁴ARC. A simple supervisor scheme to reduce the computational burden and avoid rapid switching between controllers in the system is proposed. The performances of the proposed ARC and M⁴ARC are compared with the fixed-parameter resonant control method in simulation and experimental studies.

In Chapter 6, a summary and a conclusion obtained from the research are presented and recommendations for further continuation of the research are given.

Simulink models for simulation and experimental implementations are given in Appendix C.

1.12 Original Contributions to the Thesis

To the author's knowledge, the design and implementation of the three control methods for multi-mode vibration control of a flexible structure, namely: M⁴RC (in Chapter 3), ARC, and M⁴ARC (in Chapter 5), and the multi-mode natural frequency estimator (in Chapter 4) as presented in this thesis, are original. More specifically, the original contributions are highlighted as follows:

1. A new approach to the multiple model control method using a simple supervisor scheme, M⁴RC, is proposed in Chapter 3. The M⁴RC is proposed to enable the resonant control to perform optimum vibration attenuation in systems with varying natural frequencies. The M⁴RC design is an adaptation of the multiple model method with a new supervisor scheme. The approach is new in the sense that the supervisor scheme in the M⁴RC uses a measurement of how close the system's output vibration frequencies are to the natural frequencies of the known models as the index performance to choose the optimum controller. This approach is relatively simple and less computationally complex compared to existing strategies reported in the literature. The M⁴RC also only uses a single adjustable controller per mode, while the existing multi-model methods use one controller per model. Therefore, it is more feasible to implement the M⁴RC in a real-time system.
2. A new real-time natural frequency estimator for flexible structures is proposed in Chapter 4. The proposed approach is new in the sense that the

estimator is a set of parallel second-order estimators that use different sampling periods for different modes. It is different to the classical RLS estimator, which uses a single estimator where the estimator's order is equal to the order of the system to be estimated, and the estimator uses a single-rate sampling period. Parallel structure and different sampling periods for different modes are employed to improve the accuracy estimation for wide-band multi-mode flexible structures where the frequency of the first mode is separated by more than one decade from its corresponding third mode frequency. The parallel low-order structure of the estimator has the advantages that it is more accurate, more robust and requires less computational power than its classical counterpart.

3. A new simple and robust adaptive control method, ARC, and a new approach to the multiple model adaptive control, M⁴ARC, are developed in Chapter 4. Compared to extant adaptive control methods for multi-mode vibration, the ARC has two advantages. Firstly, the ARC only uses natural frequencies as adaptation parameters. This results in a simple controller. Secondly, because the ARC only uses the natural frequencies of the system as the adaptation parameters, it is inherently robust to unmodeled dynamics caused by mode truncation. This is because the natural frequencies of the system do not change in the presence of mode truncation. Mode truncation changes the zeros of the system, but not the poles, which correspond to the natural frequencies of the system. Compared to the MMAC, M⁴ARC has two principal differences. Firstly, M⁴ARC uses a simple supervisor that utilizes information from a filter bank system and a natural frequency estimator, compared to MMAC which uses a supervisor utilising the minimum mean squares algorithm. The use of a simple supervisor in M⁴ARC, reduces the computational requirements and also avoids rapid switching. Secondly,

in the M⁴ARC only one adjustable controller is used in the system regardless of the number of models (fixed and adaptive), while in MMAC the number of controllers is equal to the number of models used in the system. Overall, M⁴ARC is simpler than MMAC, and is thus more feasibly implemented in a real-time system.

Apart from the above original contributions, this thesis also provides a general formulation of the frequency equation for a cantilever beam with two lumped masses at arbitrary positions along the beam (in Chapter 2). This ready-to-use formula can be used as a basic tool to form simulation models. These simulation models can assist in the design of vibration controllers used for flexible structures with varying parameters.

The outcomes of these three original contributions provide a basis for further research into the implementation of adaptive control applicable to a large class of flexible structures.