

**THE EFFICACY OF HOME BASED EXERCISE REGIMES
FOR LIMB OEDEMAS**

Amanda Moseley
BN, RN, BHSc(Hons)

A thesis submitted for the degree of
Doctorate of Philosophy
Flinders University
Adelaide, South Australia, Australia

School of Medicine
2007

DECLARATION

I certify that this thesis does not incorporate without acknowledgement any material previously submitted for a degree or diploma in any university; and that to the best of my knowledge and belief it does not contain any material previously published or written by another person except where due reference is made in the text.

Amanda Moseley

CONTENTS

SUMMARY	XIV
ACKNOWLEDGEMENTS	XVI
INTRODUCTION	1
CHAPTER 1. FLUID MOVEMENT AND DRAINAGE IN A ‘NORMAL’ LYMPHATIC AND VENOUS SYSTEM, A DYSFUNCTIONAL LYMPHATIC AND VENOUS SYSTEM AND THE ASSOCIATED DETRIMENTAL CHANGES	5
Fluid movement between the capillary bed and the interstitium in the normal state	5
Figure 1a. Traditional Starling principles with the inclusion of the role of the initial lymphatics	6
Figure 1b. Revised Starling principles with the inclusion of the role of the initial lymphatics	7
The reabsorption of fluid, protein and other substances by the initial lymphatics in the normal state.	8
Figure 2a. Depiction of an initial lymphatic capillary demonstrating the endothelial cells and anchoring filaments	9
Figure 2b. Depiction of the opening of an endothelial junction by tension on the anchoring filament and the movement of fluid and protein	9
Movement and reabsorption of lymph along the lymphatic system in the normal state	10
Figure 3. Depiction of a lymph collector and the role of the lymphangion and valves	10
Figure 4. Depiction of a lymph node demonstrating how lymph is filtered.	12
Lymph movement and drainage in a compromised lymphatic system	13
How the lymphatic system becomes compromised	13
Primary lymphoedema	13
Secondary lymphoedema	13
Compensatory mechanisms that can occur in a damaged lymphatic system	15
What occurs when the lymphatic system becomes overwhelmed	15
Secondary Lymphoedema	18
Possible precipitators of secondary lymphoedema	18
Changes that accompany secondary lymphoedema	18

Figure 5. Stages of lymphoedema and accompanying changes	20
Lower Limb Venous Flow in a Normal Functioning Venous System	21
Figure 6: Depiction of lower limb venous flow and the role of muscle contraction and venous valves	22
What causes the lower limb venous system to fail?	22
Figure 7: Depiction of the vein damage sustained by a deep vein thrombosis	24
The Development of Lower Limb Chronic Venous Insufficiency (CVI)	25
Figure 8: Venous hypertension causes back pressure and increased filtration at the venule end of the capillary bed.	25
Changes that accompany chronic venous insufficiency	27
The Impact of Limb Swelling Upon the Individual	29
CHAPTER 2. THE ASSESSMENT, DIAGNOSIS AND TREATMENT OF THE LYMPHOEDEMA OR VENOUS OEDEMA LIMB	30
Patient history and physical assessment	30
Limb assessment	32
Circumference	32
Limb volume	33
Using tape measurement	33
Using water displacement	35
Imaging	35
Magnetic Resonance Imaging (MRI)	35
Computerized Tomography Scanning (CT Scan) and ultrasound	36
Limb lymphatic function	36
Lymphography	36
Lymphoscintigraphy	37
Leg venous function	38
Venous doppler	38
Duplex ultrasound	38
Air plethysmography	38
Phlebography and varicography	39

Lymphoscintigraphy	39
Limb Range of Movement	40
Subjective Symptoms & Quality of Life	40
The Importance of Treatment and Management of the Lymphoedema or Venous Oedema Limb	42
Treatments for the Lymphoedema or Venous Oedema Limb	44
Peripheral Therapies	44
Surgery for Limb Lymphoedema	46
Surgical Anastomoses	46
Excisional Operations	47
Liposuction	47
Treatments for Chronic Venous Insufficiency of the Lower Limb	49
Sclerotherapy & Laser Therapy	49
Vein Stripping and Perforator Vein Ligation	50
Venous Bypass and Valve Repair/Replacement	50
The Important Role of Exercise for the Lymphoedema or Venous Oedema Limb	52
CHAPTER 3. SYSTEMATIC REVIEW OF THE EFFECTIVENESS OF COMMONLY RECOMMENDED CONSERVATIVE THERAPIES FOR SECONDARY LIMB LYMPHOEDEMA AND OEDEMA OF THE LEGS.	55
Synopsis	55
Objectives	56
Review Methods	56
Types of Studies	56
Types of Participants	56
Inclusion Criteria	57
Secondary lymphoedema of the limbs	57
Oedema of the legs	57

Exclusion Criteria	58
Secondary lymphoedema of the limbs	58
Oedema of the legs	58
Types of Interventions	59
Combined Decongestive Therapy or Complete Physical Therapy or Complex Physical Therapy	59
Manual Lymphatic Drainage	60
Self/partner massage	61
Compression (multi-layering) bandaging	61
Compression garments	62
Limb Exercises	63
Limb Elevation	63
Pneumatic Pump Therapy	63
Low Level Laser Therapy	65
Oral Pharmaceuticals	65
Types of Outcome Measures	67
Search Strategy	67
Quality Assessment	71
Analysis	71
Results	72
Legend	73
Complete Decongestive/Physio Therapy (CPT)	74
Table 3.1. Summary of Results of Complete Decongestive/Physio Therapy	80
Manual Lymphatic Drainage (MLD)	84
Table 3.2. Summary of Results of Manual Lymphatic Drainage (MLD) Trials	89
Compression (Garments or Bandaging) for Limb Lymphoedema	93

Table 3.3a. Summary of Results of Compression (Garments or Bandaging) for Limb Lymphoedema	97
Compression Garments for Leg Oedema	100
Table 3.3b. Summary of Results of Compression Garments for Leg Oedema	103
Exercise Regimes for Limb Lymphoedema	104
Table 3.4a. Summary of Results of Exercise Regimes for Limb Lymphoedema	109
Exercise Regimes for Leg Oedema	113
Table 3.4b. Summary of Results of Exercise Regimes for Leg Oedema	115
Elevation for Limb Lymphoedema	116
Elevation for Leg Oedema	116
Table 3.5a. Summary of Results of Elevation for Limb Lymphoedema	117
Table 3.5b. Summary of Results of Elevation for Leg Oedema	117
Pneumatic Pump Therapy	118
Table 3.6. Summary of Results of Pneumatic Pump Therapy	123
Low Level Laser Therapy	126
Table 3.7. Summary of Results of Low Level Laser Therapy	128
Oral Pharmaceuticals for Limb Lymphoedemas	130
Table 3.8a. Summary of Results of Oral Pharmaceuticals for Limb Lymphoedemas	134
Oral Pharmaceuticals for Leg Oedema	137
Table 3.8b. Summary of Results of Oral Pharmaceuticals for Leg Oedema	144
Comparison Graphs of the Reviewed Conservative Therapies	149
Figure 3.1a. Average percentage change for each conservative regime at end of trial in secondary arm lymphoedema	149
Figure 3.1b. Average percentage change for each conservative regime at end of trial in lower limb swelling	150
Discussion	151
Appendix 3.1. Articles Excluded from the Systematic Review	157

Appendix 3.2a. Quality Assessment Tool for Randomized Trials.	167
Appendix 3.2b. Quality Assessment Tool for Non-Randomized Trials.	168
Appendix 3.3a. Quality Ratings of Randomised Trials	169
Appendix 3.3b. Quality Ratings of Non-Randomised Trials	172
CHAPTER 4. RESULTS OF NEW EXERCISE REGIMES FOR LIMB OEDEMAS	174
Trial Methods	174
Trial Recruitment	174
Inclusion/Exclusion Criteria	175
Secondary Leg Lymphoedem	175
Secondary Arm Lymphoedema	175
Venous Leg Oedema	175
Withdrawal Criteria	176
Measurements	177
Perometry	177
Figure 4.1.a. Perometer (Pero-systems [®] , Germany); demonstrating the square measuring frame, tracking system and the adjustable limb support	178
Bioimpedance	179
Figure 4.1.b. InBody 3.0 [®] (Biospace Ltd [®] , Korea) muti-frequency (5-500Hz) bioimpedance machine; demonstrating the data display screen and hand and feet electrodes	180
Tonometry	181
Figure 4.1.c. Tonometer (Flinders Medical Centre Biomedical Engineering, Australia) demonstrating the mechanical loading, micrometer linear scale and foot plate	182
Table 4.1.a. Tonometry measurement technique for each lymphatic territory in the arm and leg	183
Subjective measurements	183
Calculation of actual oedema and percentage change	184
Secondary Leg Lymphoedema & Venous Leg Oedema Only	184

Quality of Life Questionnaire	184
Secondary Leg Lymphoedema Only	185
Lymphoscintigraphy	185
TRIAL ONE: The effect of the Sun Ancon[®] Chi Machine[®] Aerobic Exerciser which delivers leg elevation and passive exercise for those with chronic secondary leg lymphoedema	186
Abstract	186
Aim	187
Treatment Regime	187
Figure 4.1.1. The Sun Ancon [®] Chi machine [®] Aerobic Exerciser (Hsin Ten Enterprise [®] , Taiwan)	188
Measurement Schedule	188
Analysis	189
Study Population	189
Results	189
Leg Changes	189
Figure 4.1.2a. Change in median leg volume (ml's) over three weeks of treatment with the Aerobic Exerciser and then at 1 month follow up, as measured by perometry	191
Figure 4.1.2b. Change in median leg fluid (ml's) over three weeks of treatment with the Aerobic Exerciser then at 1 month follow up, as measured by bioimpedance	192
Table 4.1.1. Subjective leg symptoms - before and after treatment with the Aerobic Exerciser then at 1 month follow up	193
Whole Body Composition Changes	194
Figure 4.1.3a. Changes in whole body extra cellular fluid volume (L's) over three weeks of treatment with the Aerobic Exerciser then at 1 month follow up, as measured by bioimpedance	195
Figure 4.1.3b. Changes in body weight (Kg's) over three weeks of treatment with the Aerobic Exerciser then at 1 month follow up, as measured by bioimpedance	196
Table 4.1.2. Correlations of leg changes (volume, fluid & symptoms) and body compositional changes after 3 weeks of treatment with the Aerobic Exerciser	197
Quality of Life Changes	198

Table 4.1.3a. Improvements in certain quality of life domains after three weeks of treatment with the Aerobic Exerciser	199
Table 4.1.3b. Correlations in quality of life improvements with subjective leg symptom improvements after 3 weeks of treatment with the Aerobic Exerciser	199
Lymphoscintigraphy	200
Figure 4.1.4a. Lymphoscintigraphy: Exemplar of MBq counts indicating radioactivity transit through the affected leg before and after treatment with the Aerobic Exerciser	201
Figure 4.1.3b. Example of a participant who had an improvement in Lymphoscintigraphy after 3 weeks of Aerobic Exerciser use	202
Compliance & Side Effects	203
Discussion	203
TRIAL TWO: The effect of the Sun Ancon[®] Chi Machine[®] Aerobic Exerciser which delivers leg elevation and passive exercise for those with venous oedema of the legs	206
Abstract	206
Aim	207
Treatment Regime	207
Measurement Schedule	207
Analysis	207
Study Population	208
Results	208
Affected Leg(s) Change	208
Figure 4.2.1. Changes in median leg fluid (ml's) over three weeks of treatment with the Aerobic Exerciser then at 1 month follow up, as measured by bioimpedance	210
Table 4.2.1. Subjective leg symptoms at the beginning and end of 3 weeks of treatment with the Aerobic Exerciser and then at 1 month follow up	211
Body Composition Change	212
Figure 4.2.2. Changes in weight (Kg's) over three weeks of treatment with the Aerobic Exerciser then at 1 month follow up, as measured by bioimpedance	213

Table 4.2.2. Changes in body composition at the end of three weeks of treatment with the Aerobic Exerciser then at 1 month follow up, as measured by bioimpedance	214
Quality of Life	215
Table 4.2.3a. Improvements in certain quality of life domains after three weeks of treatment with the Aerobic Exerciser	216
Table 4.2.3b. Correlations in quality of life improvements with subjective leg symptom improvements after 3 weeks of treatment with the Aerobic Exerciser	216
Side Effects	217
Discussion	217
TRIAL THREE: The effect of gentle arm exercise combined with deep breathing on secondary arm lymphoedema	219
Abstract	219
Aim	220
Treatment Regime	220
Figure 4.3.1. Sequence of arm exercise plus deep breathing performed over 10 minutes.	221
Measurement Schedule	221
Analysis	222
Study Population	222
Table 4.3.1. Demographic details of participants in the 1 month exercise plus deep breathing (EDB) group and the 1 month control group	223
Results	224
Arm Volume Changes	224
Tonometry Changes	224
Figure 4.3.2. Median arm volume and percentage oedema reduction at various periods after performing the exercise plus deep breathing regime	225
Subjective Arm Symptoms Changes	226
Table 4.3.2. Change in subjective arm symptoms at various periods after performing the exercise plus deep breathing regime	227
1 Month Follow Up	228

Figure 4.3.3. Correlation of median arm volume reduction directly after performing the exercise regime with median arm volume reduction after 1 month of performing the exercise regime (n = 24)	229
Table 4.3.3. Change in parameters in the deep breathing plus exercise (EDB) group and the Control (CO) group at the end of 1 month	230
Adverse Effects & Compliance	231
Discussion	231
TRIAL FOUR: The effect of instructed limb exercise for those with secondary arm or leg lymphoedema	234
Abstract	234
Aim	235
Treatment Regime	235
Measurement Schedule	235
Analysis	236
Study Population	236
Table 4.4.1. Profile of arm and leg lymphoedema participants	237
Results	
<i>Arm Lymphoedema Participants</i>	238
Arm Volume Changes	238
Truncal Fluid Changes	238
Figure 4.4.1. Mean arm volume and fluid at baseline, directly after performing the instructed exercise regime and 20 minutes post regime	239
Figure 4.4.2. Mean truncal fluid in the arm lymphoedema group at baseline, directly after performing the instructed exercise regime and 20 minutes post regime	240
Subjective Arm Symptom and Range of Movement Changes	241
Table 4.4.2. Mean reductions in arm subjective limb symptoms directly after performing the instructed exercise regime	242
Table 4.4.3. Mean improvements in arm range of movement (degrees ^o) directly after performing the instructed exercise regime	242

<i>Leg Lymphoedema Participants</i>	
Leg Volume Changes	243
Truncal Fluid Changes	243
Figure 4.4.3. Mean leg volume and fluid at baseline, directly after performing the instructed exercise regime and 20 minutes post regime	244
Figure 4.4.4. Mean truncal fluid in the leg lymphoedema group at baseline, directly after performing the instructed exercise regime and 20 minutes post regime	245
Subjective Leg Symptom and Range of Movement Changes	246
Table 4.4.4. Mean reductions in leg subjective limb symptoms directly after performing the instructed exercise regime	247
Table 4.4.5. Mean improvements in leg range of movement (degrees ^o) directly after performing the instructed exercise regime	247
Discussion	248
Comparison graphs of the percentage volume change achieved by the three new exercise regimes in comparison to previously studied exercise regimes	249
Figure 5a. Percentage arm volume change for different exercise regimes in arm lymphoedema; initial (post trial) reduction and follow up reduction	250
Figure 5b. Percentage leg volume change for different exercise regimes in leg lymphoedema & venous oedema; initial (post trial) reduction and follow up reduction	251
CHAPTER 5. DISCUSSION OF THE IMPORTANCE OF EXERCISE REGIMES FOR LIMB OEDEMAS	252
RECOMMENDATIONS	261
REFERENCES	262

Summary

Both secondary lymphoedema and venous oedema of the limb are the consequence of an imbalance between tissue fluid infiltrate and drainage, which leads to interstitial fluid accumulation, tissue compositional changes, limb discomfort and morbidity. Numerous conservative therapies have been developed to address some of these negative outcomes, with a proportion of these being labour and cost intensive. This makes the investigation of cost effective and easy to implement home based regimes very important. One such therapy is limb exercise, which can be beneficial for limb oedemas through changes in both interstitial pressure and calf muscle activation. The potential benefits of exercise certainly justify further investigation to help determine it's viability as a self instigated therapy for limb oedemas.

A systematic review of existing conservative therapies (including limb exercise) revealed varying, and at times not very rigorous outcomes for those with limb oedemas. Some claims of treatment outcomes were quite startling, with a volume reduction of 652mls in one complex physical therapy study. In other studies the limb volume reductions were smaller, especially in the self maintenance therapies. All reviewed therapies that measured subjective limb symptoms found that these were improved, whether the participants were receiving active or placebo treatment. Studies which included a follow up period demonstrated that a form of additional therapy needed to be undertaken to maintain the initial improvements in limb volume and subjective symptoms. This also needs to be considered when determining the benefits of the reviewed therapies, as some require significant clinical and economic resources.

Four clinical trials were then conducted on three new exercise regimes for oedematous limbs. The first regime investigated leg elevation and passive exercise for lymphoedema and venous oedema of the legs. Both groups experienced a significant reduction in limb volume, weight, and reported skin dryness, pain, heaviness, tightness, limb size plus improvements in quality of life parameters such as depression and physical activities. Some improvements were also maintained at the one month follow up, most notably body weight, skin dryness and perceived limb size.

A 10 minute deep breathing plus arm exercise regime for secondary arm lymphoedema initially achieved reductions in arm volume, truncal fluid and perceived heaviness and tightness, with greater reductions in these parameters being achieved when this regime was performed over a 1 month period. A pilot study of combined deep breathing, self massage and sequential limb exercises for secondary arm and leg lymphoedema demonstrated a small volume reduction for those with arm lymphoedema but a greater reduction in those with leg lymphoedema. However, both groups experienced positive improvements in perceptions of limb heaviness, tightness and range of movement.

The limb reductions and improvements achieved by these exercise regimes were sometimes similar to and at other times greater than those obtained in previous exercise studies and existing conservative therapies administered by clinicians and/or the patient. The systematic review in combination with the clinical trials has demonstrated the multifaceted benefits of limb exercise, including limb volume reduction and improvements in subjective symptoms, limb function and quality of life issues. This makes exercise a cheap and easy to implement adjunct or alternative regime for those with limb oedemas.

Acknowledgements

I would like to acknowledge and thank Professor Neil Piller (Principal Supervisor), Associate Professor Colin Carati and Dr Jack Walsh (Co-Supervisors) who have all been kind, patient and guiding mentors through out this process. I would also like to thank Adrian Esterman (Biostatistcian) who provided invaluable advice for the statistical analysis of the clinical trials, Margi Moncrieff (Wound Care Nurse Consultant) and Dr Jack Walsh (Vascular Specialist) who helped in the recruitment of patients and Gillian Buckley (Physiotherapist) who was the co-investigator of the instructed self massage and sequential limb exercise pilot study.

Thank you to Hsin Ten Enterprise[®] who provided the financial support through Flinders Consulting Pty Ltd. for the Aerobic Exerciser trial and the Lyn Wrigley Foundation (Australia) for providing the research grant for the arm exercise plus deep breathing trial. Special thanks to all the participants who generously volunteered to participate in these clinical trials. Lastly, I would like to thank my husband David, who unwaveringly supports all the endeavours I undertake in life.

Introduction

Secondary lymphoedema and venous oedema of the limbs represent an imbalance between tissue infiltrate and drainage which resultant limb swelling, detrimental vessel and tissue changes and reduced quality of life. Surprisingly, these conditions effect a significant number of the population, with an estimated 30% of people developing secondary limb lymphoedema as a sequelae of cancer treatment (Williams, Franks & Moffatt 2005; Deo, Ray, Rath et al 2004), with chronic venous insufficiency and subsequent lower limb oedema affecting 4-5% of the population in developed countries (Stafa 2002; Fowkes, Evans & Lee 2001). These conditions have a personal and socioeconomic impact upon the individual and an economic impact upon the health care system, which treats not only the primary conditions, but also their co-morbidities (such as ulceration and cellulitis).

Therefore it is in the best interest of both the individual and the health care system to implement therapy to reduce the risk of these conditions developing and to halt their progression when they do occur. Unfortunately, universal access to effective and beneficial treatment for these conditions is currently not available. Globally, treatment access is reliant upon the resources each health care system can provide for treatment and the availability of suitably qualified clinicians who can both accurately diagnose and treat the conditions. Individually, access is reliant upon the person's time availability, financial resources and geographical location (for example, city versus rural living).

These access issues make the establishment of beneficial and cost effective home based treatment regimes very important. In particular, exercise can be cost effective and easy to undertake in the home environment and therefore a potentially very beneficial maintenance tool in both lymphatic and vascular limb swelling. Although exercise has been traditionally incorporated into overall therapy programs for limb oedemas, and has been shown to be beneficial in combination with complex physical therapy (Casley-Smith 1997; Swedborg 1980), compression and massage (Leduc, Peeters & Borgeois 1990; Olszewski & Engeset 1988), it's stand alone effects and benefits have only recently been explored.

This may partly be related to clinicians traditionally being hesitant in recommending exercise for those with limb oedemas, in the fear that the increased muscular blood flow would precipitate or exacerbate the oedema, not help it. However, research has demonstrated that strenuous exercise does not always exacerbate the pre-existing swelling or contribute to it's development (Turner, Hayes & Reul-Hirche 2004; McKenzie & Kalda 2003; Kahn, Azoulay, Hirsch et al 2001; Harris & Niesen-Vertommen 2000; Ciocon, Galindo-Ciocon & Galindo 1995). In fact, it has been shown that exercise changes interstitial tissue pressure and therefore has crucial benefits for limb oedemas. These benefits include increased lymph flow (Havas, Lehtonen, Vuorela et al 2000; Mazzoni, Coates, O'Brodovich & Goeree 1993; Skalak & Schönbein 1990) and transport of inflammatory proteins (Olszewski & Engst 1998; Havas, Parviainen, Vuorela et al 1997). Exercise also activates the calf muscle pump, which increases venous ejection fraction in those with lower limb oedema subsequent to chronic venous insufficiency (Padberg, Jrohston & Sisto 2004; Yang, Vandongen & Stacey 1998).

As patients with limb oedemas have variable access to conservative therapies, alternative or adjunct regimes that contribute to limb maintenance, are easy to implement and cost effective are most certainly needed. Considering previous research has shown that exercise maybe beneficial, both for oedema arising from lymphatic and/or vascular dysfunction, further research into new modalities that use exercise as their core component is warranted. Therefore, this thesis explores the benefits of different exercise regimes for limb oedema of both lymphatic and vascular origin. This is achieved through;

- An exploration of normal and detrimental lymphatic and venous flow in the limb and what occurs when the lymphatic and venous systems fail
- An exploration of the importance of accurate diagnosis, measurement and treatment of the oedematous limb
- A systematic review of commonly recommended conservative therapies for limb oedemas, including;
 - Complex physical therapy
 - Manual lymphatic drainage
 - Self massage
 - Compression (bandaging and garments)
 - Limb exercise
 - Limb elevation
 - Low level laser therapy
 - Pneumatic pump therapy
 - Oral Pharmaceuticals

- A comparison of the average percentage reduction achieved by the reviewed conservative therapies
- The presentation of four clinical trials which investigated the benefits of different exercise regimes for limb oedemas, including;
 - Limb elevation and passive exercise for secondary leg lymphoedema and venous oedema of the legs
 - Combined deep breathing and arm exercise for secondary arm lymphoedema
 - Instructed deep breathing, self massage and sequential limb exercises for secondary arm and leg lymphoedema
- A comparison of the percentage oedema reduction achieved by the new exercise regimes against the reductions achieved by previously studied exercise regimes.
- An exploration of the overall volume reductions and improvements in subjective symptoms, quality of life and range of movement achieved by the new exercise regimes in comparison with existing exercise regimes, self maintenance therapies and health professional administered therapies.

Chapter 1. Fluid movement and drainage in a ‘normal’ functioning lymphatic and venous system, in a dysfunctional lymphatic and venous system and the associated detrimental changes

Fluid movement between the capillary bed and the interstitium in the normal state

For over 100 years, the ‘Starling Principle’ (expanded upon by Landis) has been accepted as an accurate depiction of fluid exchange between the microcirculation and tissues, where fluid moves out of the arterial end and is reabsorbed at the venule end of the capillary system. More specifically, this original work proposed that fluid fluxes were dependent upon net hydrostatic and colloid osmotic pressures (Michel 1997; Levick 1991). Therefore, at the arterial end of the microcirculation (where hydrostatic pressure is high), fluid (plus dissolved substances) are filtered or ‘forced’ across the capillary membrane into the interstitium whilst at the venous end (where colloid osmotic pressure is high), fluid plus dissolved by-products are reabsorbed or “pulled” from the interstitium back into the capillary (figure 1a). Reabsorption of fluid and especially protein was also noted to occur via the initial lymphatic capillaries, so that the movement of fluid was seen to be perfectly balanced between arterial infiltration and both venule and lymphatic reabsorption.

Figure 1a. Traditional Starling principles with the inclusion of the initial lymphatic capillaries

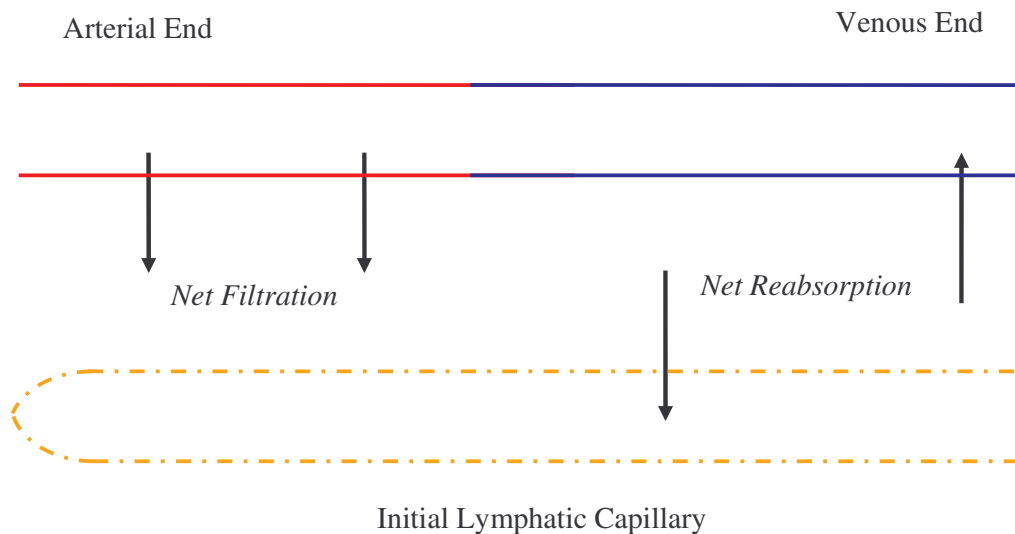

However, re-examination of this original work has concluded that a sustained reuptake of fluid at the venous end of the capillary bed is not to be expected, especially in tissues such as skin, muscle or mesentery (Michel 1997). This is due to the discovery of capillary junction strands with small breaks and pores, which greatly inhibit back diffusion of fluid from the interstitium (Hu, Adamson, Liu, Curry & Weinbaum 2000). This is not to say that it doesn't occur at all, just that it is more likely to be a transient phenomena. Experiments have also shown that filtration from the capillary does not only occur at the arterial end of the microcirculation but also extends into the venular end (Levick 1991). Hence, fluid movement is now considered to be a more complicated phenomenon, where filtration occurs along the majority of the capillary bed (albeit in small amounts at the venular end) with reabsorption

occurring only transiently at the venule end of the capillary system (figure 1b). This leaves the initial lymphatics as the major reabsorber of fluid, its constituents and protein and therefore a vital component in the maintenance of the interstitial fluid balance in the normal state.

Figure 1b. Revised Starling principles with the inclusion of the initial lymphatic capillaries

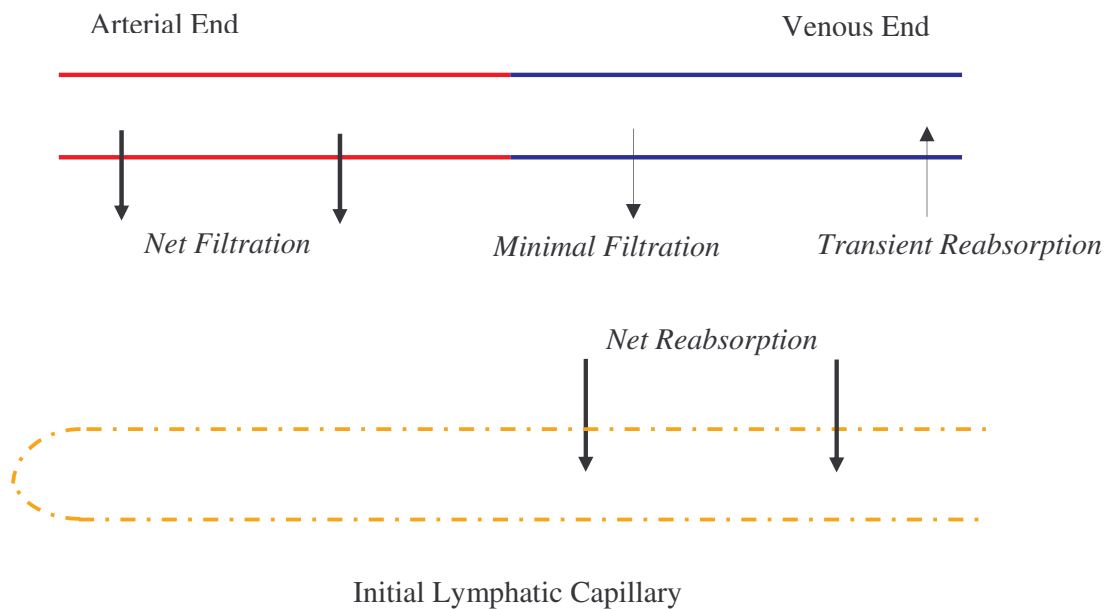

The reabsorption of fluid, protein and other substances by the initial lymphatics in the normal state.

Along with fluid and dissolved substances, a small amount of plasma protein also moves across the capillary wall at the arterial end, with the amount of protein leaving the circulation per unit of time being constant (Földi 2003), unless the permeability of the capillary membrane is increased. The continual input of filtrate from the arteriole end helps to move this protein away from the capillary and into the lymphatic system (Levick 1991); where in a normally functioning system it is drained away.

Protein, fluid, fats (Weissleder & Schuchhardt 2000) and endogenous cells such as macrophages and erythrocytes (Berens von Rautenfeld & Schacht 2003) enter the lymphatic system via the initial lymphatic capillaries, which are located in close proximity to the vascular microcirculation. These blind ended capillaries have an outer layer of overlapping endothelial cells which are connected to the interstitium via anchoring filaments (figure 2a). When there is a fluid influx into the interstitium and subsequent expansion, there is a resultant pulling force on these anchoring filaments, causing some of the endothelial cells to open (figure 2b). This allows the movement of fluid and substances into the lymphatic capillary, with the endothelial cells closing behind to prevent back diffusion into the interstitium. Work undertaken by Azzali (1999) also suggests that intraendothelial channels (which may aid fluid absorption) exist in the endothelial wall, with the number of these channels varying according to different physiological conditions and the degree of colloid and hydrostatic pressure.

Variations in interstitial pressure caused by arterial pulsation, respiration and muscle contraction also provide tension on the anchoring filaments, enhancing the transport of fluid and substances into the initial lymphatic capillaries (Weissleder & Schuchhardt 2000; Mortimer 1995).

Figure 2a. Depiction of an initial lymphatic capillary demonstrating the endothelial cells and anchoring filaments

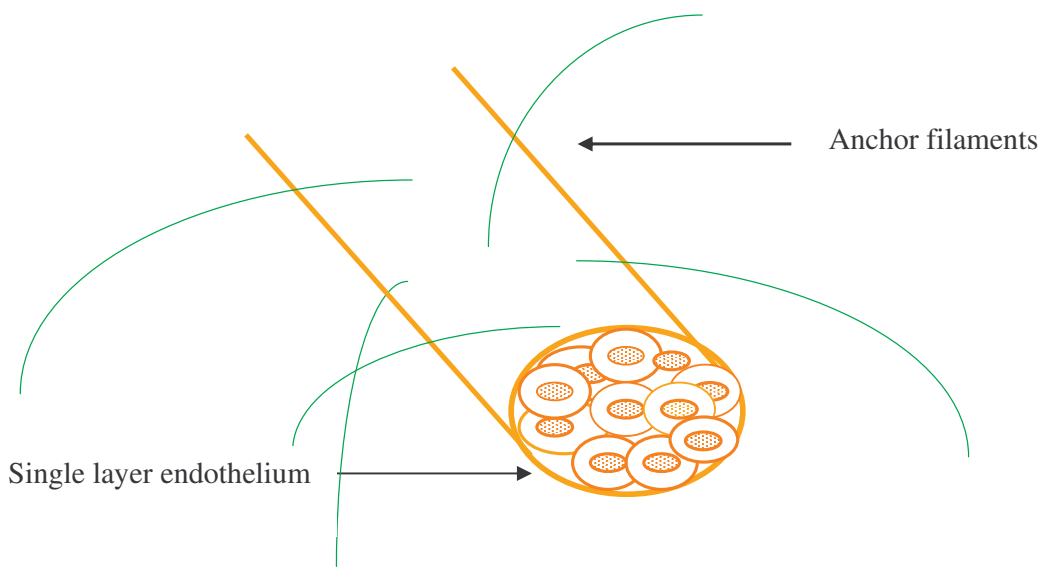
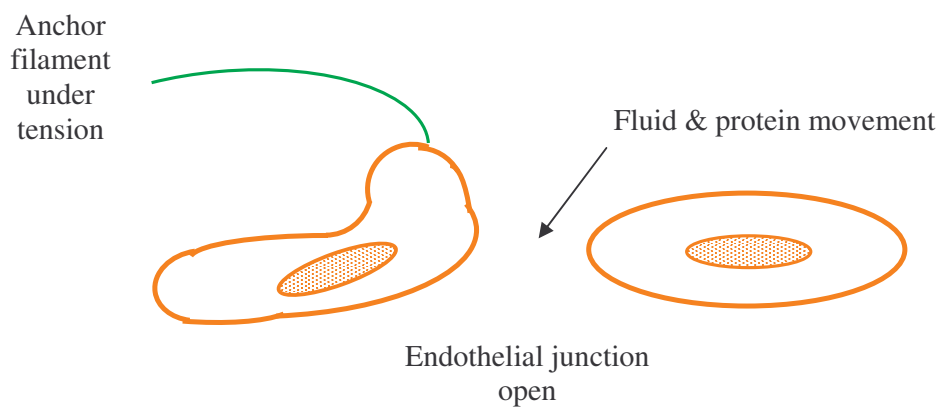

Figure 2b. Depiction of the opening of an endothelial junction by tension on the anchoring filament and the movement of fluid and protein



Movement and reabsorption of lymph along the lymphatic system in the normal state

The dense lymphatic capillary network is located in the subcutaneous layer of the entire body and normally converges into deeper lymphatic collectors towards the root of the limbs (Hidden 1990). The lymphatic collectors, which are located within the deeper epifascia, transport the lymph via the contraction of the smooth muscle lining (Schmid-Schönbein 1990) and the autonomic relaxation and contraction of lymphangions. The lymphangions were first described by Mislin (1978) and are the structural unit of the system that generates the propulsive force needed to drive the lymph along the collector (Szuba & Rockson 1997). These segments in fact behave like mini hearts in succession, with their contractile cycle being similar to that of the cardiac cycle (Mortimer & Levick 2004). The valves located within the lymphatic collectors close behind the fluid ensuring unidirectional movement and prevention of retrograde flow (figure 3).

Figure 3. Depiction of a lymph collector and the role of the lymphangion and valves

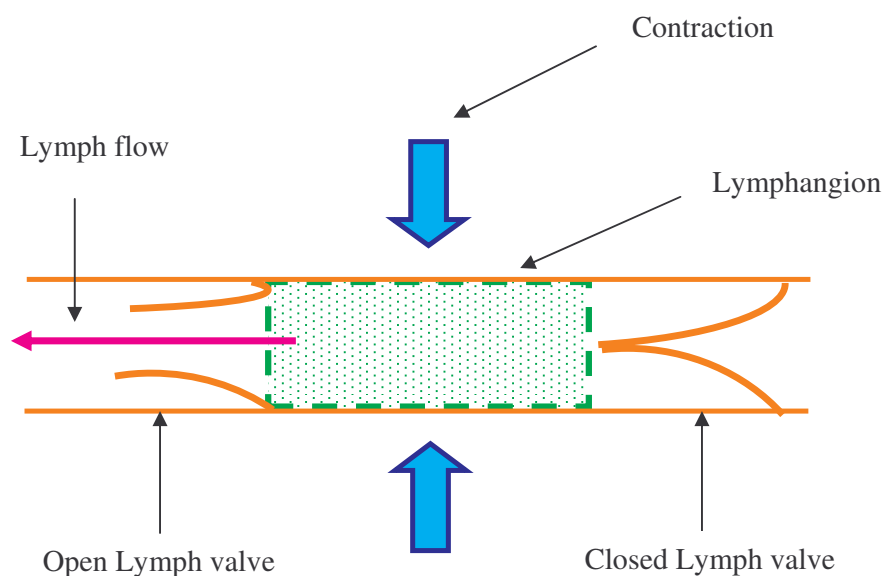

The stimulus for lymphangion contraction is the filling of the lymphangion segment (Mortimer 2000; Gallagher, Garewal, Drake & Gabel 1993); hence the relaxation and contraction cycles are dictated by the supply of lymph to the collectors. An increased volume of lymph caused through physical exercise, heat or infection may result in increased pulsation frequency of the lymphangions (Weissleder & Schuchhardt 2000), with resultant increased lymphatic transport. The lymphatic collectors are divided into different lymphatic drainage territories, which were first described by Sappey in 1874. These territories are separated by boundaries called watersheds (Kubik 2003; Kasseroller 1998) and are connected via anastomoses, which ensure that lymph moves into neighboring territories and eventually towards the ducts for drainage (Kubik 2003).

Located along the lymphatic collectors are lymph nodes, which sometimes occur singularly but most often in groups and which are specifically concentrated in the neck, thoracic and deep abdominal areas, axilla, and groin. The lymph transported along the lymphatic collectors percolates through these nodes (figure 4) which have multiple functions, including; lymph concentration (Schad 1996), lipolysis (Pond & Mattacks 2002), immuno-modulation (Gutting, Schomaker, Kaplan, & Amacher 1999) and cell mediated and humoral immunity (Kaiserling 1999).

Figure 4. Depiction of a lymph node demonstrating how lymph is filtered.

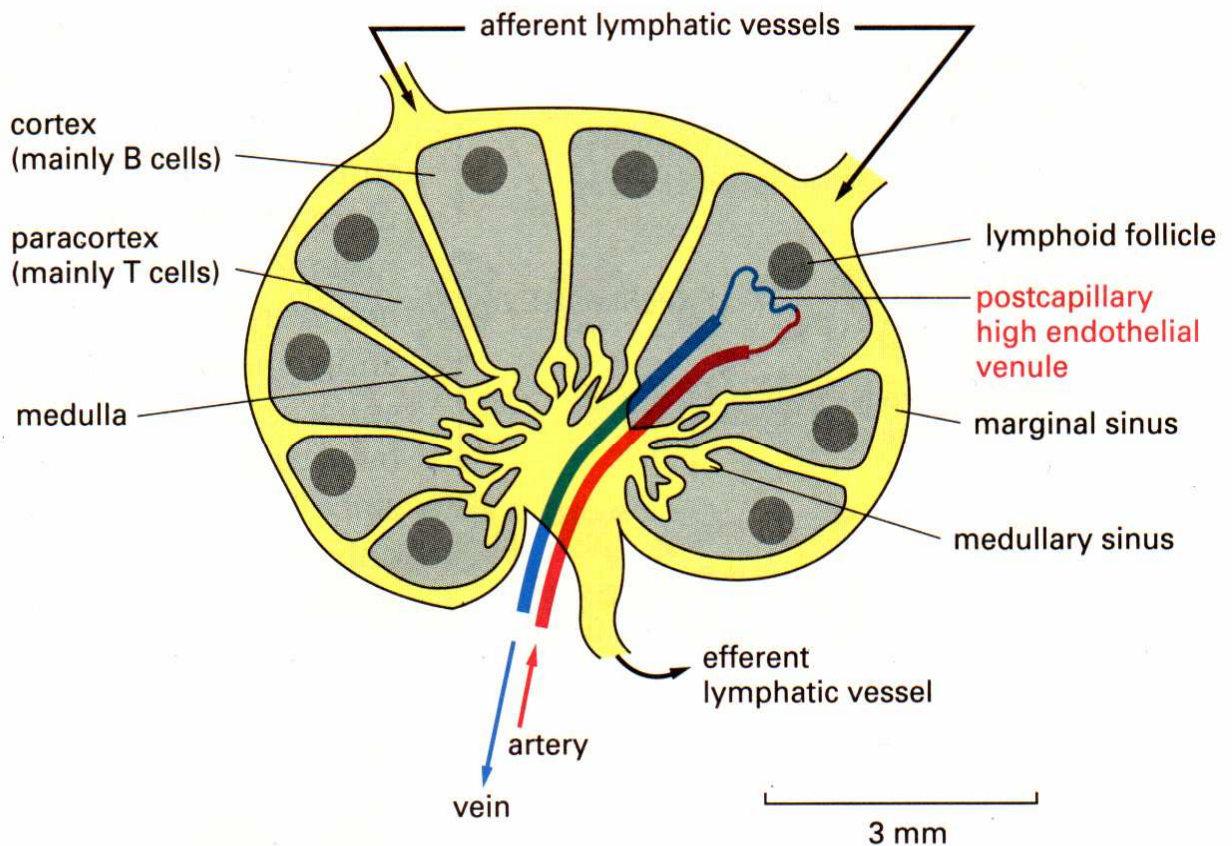

Adapted from Weissleder & Schuchhardt (2000)

It has also been shown that water reabsorption occurs in the venous capillary network located within the lymph nodes (Kubik 1999; Adair & Guyton 1985, 1983), with this absorption process appearing to be passive and one that obeys Starling's principles of fluid exchange (Levick 1991). The remaining lymph is then returned to the cardiovascular system via the thoracic and right lymphatic ducts, which terminate at the junctions of the left and right internal jugular and the subclavian veins (Gray 2002).

Lymph movement and drainage in a compromised lymphatic system

How the lymphatic system becomes compromised

Primary Lymphoedema

People can be born with a malformed and therefore dysfunctional lymphatic system which struggles to adequately remove lymph from certain tissues; this is known as primary lymphoedema. The different forms of primary lymphoedema were first proposed by Kinmonth and encompass reduced development (aplasia) of the lymph capillaries (Nonne-Milroy syndrome), reduced number and diameter (hypoplasia) of lymph collectors (Turner's and Noonan's Syndromes) and hyperplasia of the initial lymphatics and lymph collectors (Földi & Földi 2003). Primary lymphoedema is often hereditary, can occur in one or multiple areas of the body and may manifest at birth (congenital), during adolescents (praecox) or in middle age (tardum) (Casley-Smith & Casley-Smith 1994). Primary lymphoedema can also underlie a secondary lymphoedema.

Secondary Lymphoedema

This condition arises subsequent to lymphatic system damage, which results in dysfunctional lymph drainage and transport. This can occur through mechanical obstruction such as malignancy, surgical and/or radiological scarring, Baker's cysts (although uncommon) and through the inflammatory response to worm infestation (filariasis) or bacterial infection (Földi & Földi 2003).

The focus of this thesis will be secondary lymphoedema subsequent to cancer surgery and radiotherapy. The majority of cancer treatment involves the removal of the malignant tumour plus lymph nodes in the immediate area to determine tumour progression and the need for further additional therapies such as chemotherapy and/or radiotherapy. It is the removal of these lymph nodes that causes the primary insult to the lymphatic system (Soran, Aydin, Harlak et al 2005), as it damages the lymph vessels and diminishes the transport capacity through the operated area.

The secondary insult to the system comes from radiotherapy to the area, with radiotherapy to the root of a major drainage area (ie: axilla or groin) being known to contribute to lymphoedema development (Ozaslan & Kuru 2004; Bilek, Ebeling, Leitsmann & Seidel 1981). Radiotherapy also reduces lymphatic transport capacity, predominantly in two ways. Firstly, the irradiated tissue becomes fibrotic and hard (Johansen, Taagehoj, Christensen et al 1994), which impinges upon the lymphatic collectors (Casley-Smith & Casley Smith 1994). Secondly, the irradiation causes fibrotic changes to the lymphatic vessels themselves (Kohler, Michel & Zimmermann 1995), resulting in the narrowing of the vessel lumen (Kuhn, Molnar & Bohm 1979) and therefore reduced lymphatic transport capacity. Some radiotherapy treatment fields also encompass adjacent lymphatic pathways (ie: breast irradiation may also cover the supraclavicular nodes), hence alternate pathways which could potentially be used to re-route lymph may also become compromised.

Compensatory mechanisms that can occur in a damaged lymphatic system

Once the lymphatic system has sustained damage, it will respond to the disruption in a number of ways in an effort to compensate. Firstly, it will increase local transport capacity, as the amount of lymph being presented to the intact lymph collectors (and their associated lymphangions) is increased. As the increase in transport capacity cannot be sustained indefinitely, other mechanisms that help to re-route the lymph may also be employed. This re-routing process may occur through lymphangiogenesis, recruitment of dormant lymph vessels, (Stanton, Svensson, Mellor et al 2001), established or created lymphatico-venous communications (Aboul-Enein et al 1984) or lympho-lymphatic anastomoses (Weissleder & Schuchhardt 2000). This re-routing may also explain why some people never develop overt lymphoedema after cancer treatment.

What occurs when the lymphatic system becomes overwhelmed

Swelling of the tissues, whether it be in one region or the whole limb occurs when the compensatory mechanisms do not occur or they fail, resulting in an increasing accumulation of lymph awaiting removal and transport. Over time, the sustained overloading of the remaining intact vessels leads to chronic hypertension and dilatation with resultant valvular insufficiency, dermal backflow and lymphostasis (Kubik 2003; Mortimer 2000; Szuba & Rockson 1997).

The increase in interstitial volume also causes the elastic fibers connected to the initial lymphatic capillaries to degenerate and lose their elasticity (Daroczy 1992; Gerli, Ibba & Fruschelli 1990). This results in decreased lymph uptake, as the lymphatic capillaries lose their ability to immediately react to constantly changing pressure in the surrounding interstitium. All of these pathological changes further diminish the lymphatic system's ability to both drain and transport lymph.

Traditionally, it was thought that this was caused by a 'stop cock' mechanism where lymph outflow was blocked, resulting in a diminished ability to drain fluid from the interstitium and transport it along in an effective manner. The decreased uptake at the interstitial interface was then thought to result in not only the build up of fluid but also protein, hence lymphoedema was classified as a 'high protein oedema' (Casley Smith 1997).

It is this protein which is thought to contribute to the many subsequent and negative changes often observed in lymphoedema, including the deposition of collagen with resultant fibrotic induration of the tissues (Knight et al 1987; Piller & Clodius 1978), subclinical inflammation (Casley-Smith & Casley-Smith 1992; Gaffney & Casley-Smith 1981) and a delayed immune response in the affected limb, related to the decreased reaction to foreign material by macrophages that are exhausted by the phagocytosis of the additional protein (Piller 1980).

However, the labelling of lymphoedema as a 'high protein' oedema has become somewhat controversial, as some research has suggested that this may not always necessarily be the case. In particular, Olszewski (2003) has reported that the protein concentrations in lymph tissue fluid of the extremities remain within normal limits in lymphoedema of stages I through to III, whilst research by Bates, Levick & Mortimer (1993) in lymphoedematous arms showed

lower interstitial protein concentrations in the affected arm compared to the normal arm. Research undertaken by Stanton et al (2001) has also questioned the 'stop cock' explanation of lymphoedema development, as they have demonstrated that in some regions of the lymphoedematous arm (predominately areas that weren't swollen) there were increased and not decreased rates of lymphatic flow.

Other factors which may exacerbate lymphoedema have also been identified. Of specific note is the finding of increased arterial flow in the lymphoedemous compared to the normal arm by Svensson et al (1994) and confirmed by Martin & Földi (1997). This may not only increase infiltrate and therefore the amount of lymph awaiting removal from the interstitium, but also provides an explanation for the observed decreased interstitial protein by Bates et al (1993), as the increased infiltrate may help to move the accumulated interstitial protein towards the initial lymphatic capillaries for drainage.

Although further research is required to confirm all that occurs in response to lymphatic system damage, it is a much more complex picture than a simple 'stop cock' explanation. Irrespective of the reasons, the consequences of this damage ultimately lead to the development, progression and problems of secondary lymphoedema.

Secondary Lymphoedema

Possible precipitators of secondary lymphoedema

Although secondary lymphoedema can develop any time after cancer treatment, the average time to onset is around three years (Petrek, Senie, Peters & Rosen 2001). This 'lag' period may be related to the undetectable occurrence of subtle limb changes or to the compensatory lymphatic mechanisms working up until a point but eventually becoming overwhelmed. Any situation which causes an additional increase in the lymphatic load may contribute to this 'overwhelmed' state and therefore be considered a precipitating factor. These may include infection, local trauma or heat exposure, which can cause an increased lymphatic load through vasodilation and increased vascular leakage into the tissues (Cohen et al 2001; Casley Smith, Boris, Weindorf & Lasinski 1998). Conditions such as chronic venous insufficiency (to be discussed later in this section), hypertension or a dysfunction in thyroid, cardiac, liver or kidney activity can also contribute to an increased lymphatic load.

Changes that accompany secondary lymphoedema

Lymphoedema is not a static condition, but one that progresses through different stages, all of which have accompanying sequelae. Although the process is a continuum, the changes can be divided into four stages which have been described by Weissleder & Schuchhardt (2000) and Bernas et al (2001) as follows:

Latent Phase: patient reports subjective limb symptoms and transient swelling which is indicative of impaired lymphatic transport.

Stage I: reversible soft/doughy tissue swelling which is easy to indent and which resolves upon elevation. No skin alterations and negative or borderline Stemmer sign. Limb volume difference is minimal (< 20% increase).

Stage II: irreversible swelling with pronounced fibrosis and skin alterations, which does not resolve upon elevation. The ‘Stemmer’ sign is positive. In the earlier stage pitting is evident, but becomes less so when fibrosis develops. Limb volume difference is moderate (20 – 40% increase).

Stage III: classed as lymphostatic elephantiasis, which has marked subcutaneous fibrosis and/or sclerosis, severe skin alterations (ie: thickening and papillomatosis) with extreme susceptibility to infections (cellulitis). Limb volume difference is severe (> 40%).

Essentially lymphoedema progresses from a state of pure tissue fluid accumulation to one that involves both adipose proliferation (Rockson 2004; Casley-Smith, Clodius & Piller 1980) with a subsequent increase in subcutaneous fat (Brorson 2003; Case et al 1992) and fibrotic induration (Piller 1980; Piller & Clodius 1978; figure 5). Each step in this continuum also makes the overall condition harder to treat.

There is also an increased susceptibility to infection and subsequent cellulitis in the lymphoedematous limb due to the decreased effectiveness of both the specific and general immune responses. This is believed to be related to the additional tissue protein providing a medium for bacterial proliferation (Herpertz 1998), sluggish macrophages that take longer to phagocytose the present bacteria (Piller 1990) and fewer lymph nodes to intercept and attack foreign bacteria and antigens (Kubik 2003).

Figure 5. Stages of lymphoedema and accompanying changes

Normal Leg:

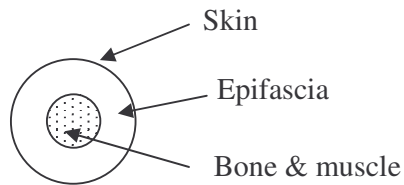

Stage I: A)

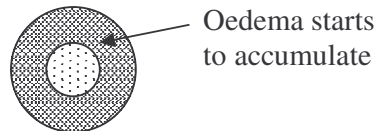

B)

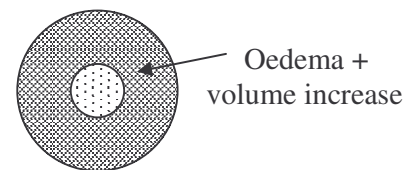

Stage II:

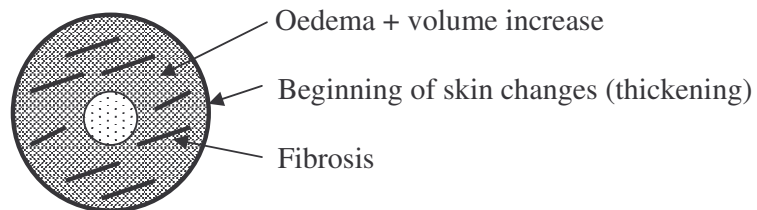

Stage III:

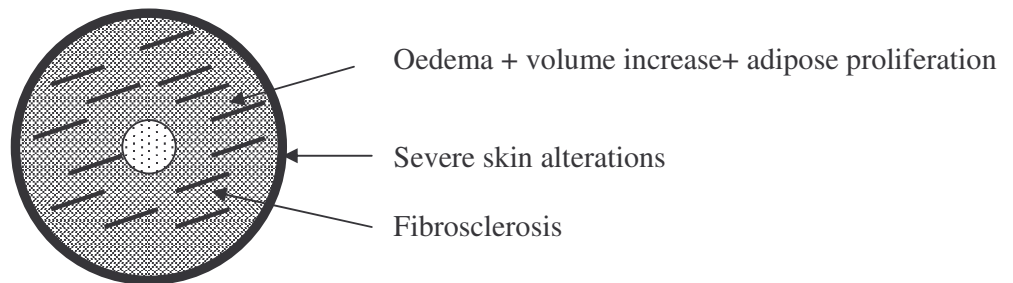

Adapted from Weissleder & Schuchhardt (2000)

Lower Limb Venous Flow in a Normal Functioning Venous System

The primary function of the venous system is to return blood from the peripheries to the heart. Veins are thin walled, low pressure vessels which commence as tiny plexuses which communicate with the capillary network. The branches that originate in these plexuses unite to form into the superficial veins which reside in the superficial fascia, which in the lower limbs constitutes the greater (long) and lesser (short) saphenous veins (Gray 2002). The superficial venous system connects via perforating (also known as communicating) veins to the deeper venous system which reside in the deep fascia. In the lower limb the deep venous system constitutes the femoral, popliteal and tibial veins (Varma & Pappas 2004). From the femoral vein blood is returned to the heart via the iliac veins and the inferior vena cava.

Lower limb venous flow in a normal system is always inwards (from the superficial to deep system) and upward, and is influenced by pressure variations caused by respiration, muscle relaxation and contraction, vein collapsibility and transmitted retrograde flow from right atrial contractions (Strandness 1976). The most important factor for lower extremity venous flow is the muscle variations produced by the calf muscle (Recek 2004). The pressure caused by calf muscle contractions essentially 'squeezes' the veins, helping to drive the blood forward. During muscle relaxation, bicuspid venous valves located within the veins close behind the blood to ensure unidirectional flow (figure 6). These venous valves are thin endothelial flaps which protrude from the vein wall and which occur at variable anatomical intervals (Limura, Nakamura & Itoh 2003) throughout the superficial and deep systems and at vein junctions. In a normal functioning venous system both the calf muscle and the venous valves help to prevent lower limb venous stasis related to the effects of gravity.

Figure 6: Depiction of lower limb venous flow and the role of muscle contraction and venous valves

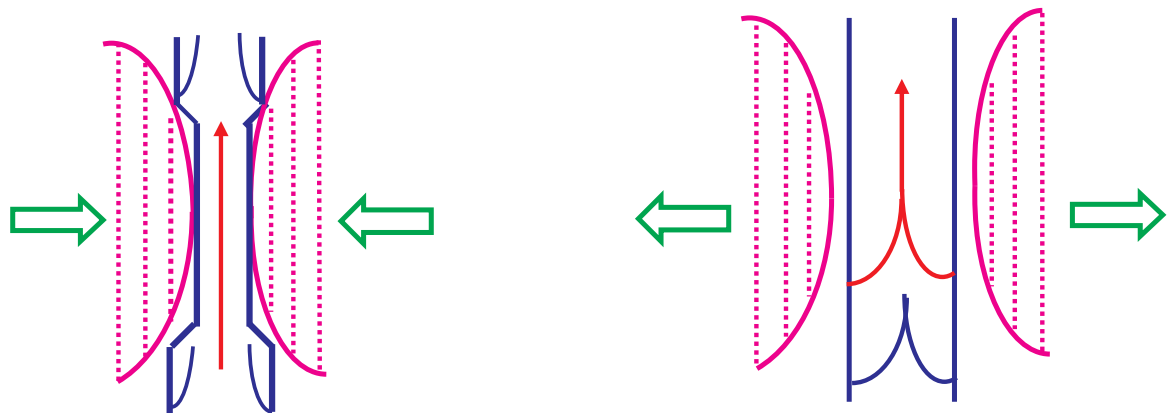

Muscle Contraction
*muscle compresses
venous segment
driving blood forward
through the open
bicuspid valves*

Muscle Relaxation
*Venous valve closes to
ensure unidirectional
flow*

What causes the lower limb venous system to fail?

Failure can occur anywhere in the venous system, including the superficial, communicating or deep systems. The most common cause of deep system incompetence is the damage sustained from deep vein thrombosis (DVT). The mechanical blockage caused by the clot slows or stops the venous flow, causing chronic venous hypertension within the vein and resultant vein dilation and venous valve stretching distal to the blood clot.

The inflammatory reaction associated with the DVT also causes vein wall fibrosis (Varma & Pappas 2004), which narrows the vessel and further slows venous outflow. The damage sustained by the venous valves results in an inability to close together properly (Van Bemmelen et al 2002) and ensure uni-directional venous flow. This in turn allows chronic reflux to occur, increasing the hydrostatic pressure in the affected vessel (figure 7). This occurs subsequent to the resolution of the DVT and is termed 'post thrombotic syndrome'.

Interestingly, the development of venous insufficiency from the valvular damage and incompetence can be quite slow, with Van Haarst et al (1996) finding that it occurred in patients up to 5 years after DVT resolution. A proportion of patients who experience deep vein thrombosis do not go on to develop post thrombotic syndrome, as adequate venous outflow is restored through the development of collateral circulation and/or recanalization of the obstructed vein (Labropoulos et al 1997).

Apart from deep vein thrombosis (which is the most common cause of venous obstruction), other factors which can produce the same outcome include tumour compression, retroperitoneal fibrosis or infection, herniation, arterial aneurysm or Baker's cyst (Kerr, Watson & Dalsing 2004).

Figure 7: Depiction of the vein damage sustained by a deep vein thrombosis

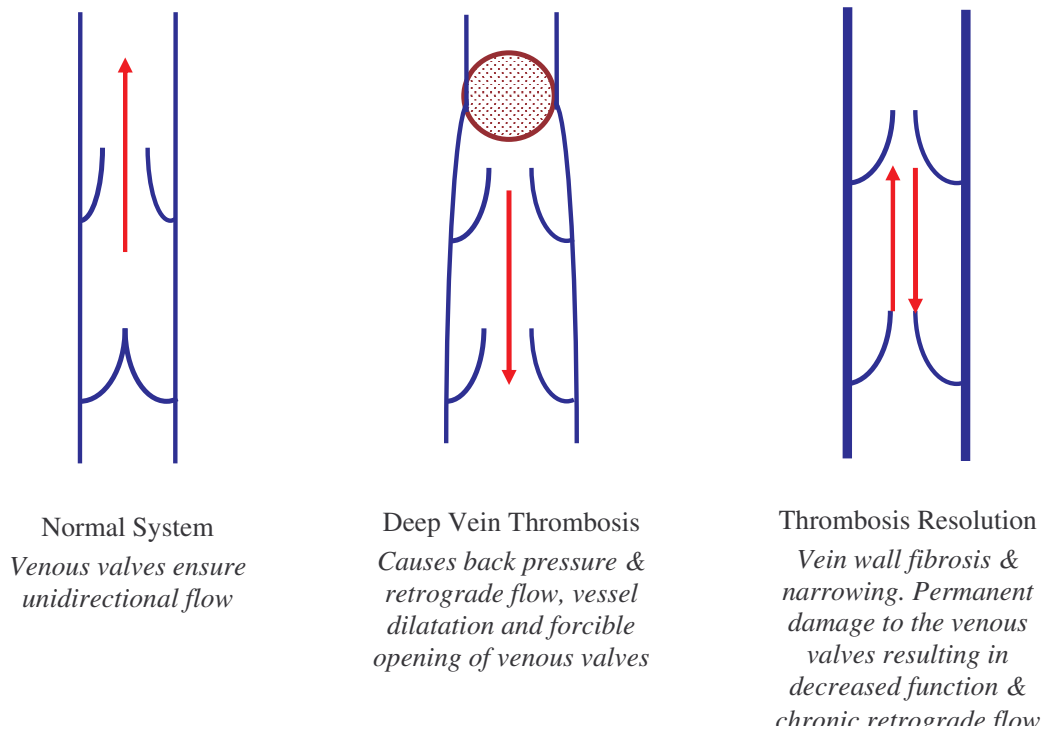

The superficial venous system predominately fails through faulty venous valve function which can occur through abnormally formed valves known as primary (congenital) varicosities or secondary varicosities, which occur through sustained vessel dilatation produced by standing for long periods of time (Sadick 1992), hormonal changes (ie: pregnancy) and vein infection (ie: phlebitis) or injury (Feied & Weiss 2004). Superficial vessel dilatation can also be the consequence of sustained reflux from the deep system through incompetent perforating veins or vein junctions (ie: saphenofemoral). Lastly, calf muscle atrophy caused through reduced mobility, injury or neurological disease (Orsted, Radke & Gorst 2001) can also contribute to decreased venous outflow and subsequent incompetence through reduced blood volume ejection from the affected leg (Heinz 1994).

The Development of Lower Limb Chronic Venous Insufficiency (CVI)

In a normal venous system, during ambulation, blood volume is pushed along and out of the lower limb via the deep system resulting in a low hydrostatic venous pressure which slowly rises post ambulation. Venous system damage results in the blood being unable to move along or out of the lower limb effectively, with the venous hydrostatic pressure remaining constantly high. This leads to chronic venous hypertension, reflux and back pressure, which is finally transferred to the venous microcirculation. At the microcirculatory level this pressure forces more fluid across the capillary wall at the venule end, resulting in increased tissue infiltrate (Weissleder & Schuchhardt 2000). The outcome of this is an increased load on the lymphatic system, which then becomes responsible for the reabsorption of the extra infiltrate (figure 8).

Figure 8. Venous hypertension causes back pressure and increased filtration at the venule end of the capillary bed.

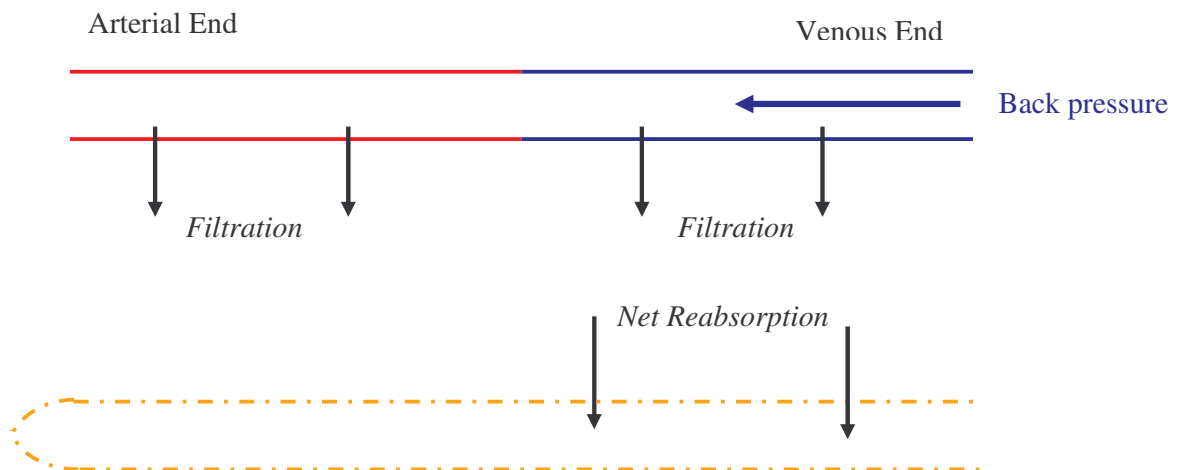

The increased infiltrate at the venous end of the capillary network is initially buffered by the increased filtration rate (which lowers interstitial protein concentration), the rise in interstitial pressure (tissue stiffness), and an increase in lymphatic flow (Mortimer 2000; Nicolaides 2000). However, these buffering mechanisms have finite effectiveness, with the continual efficient functioning of the lymphatic system being the most crucial factor.

As described earlier, the lymphangions of the lymph collectors will increase their propulsion rate and therefore lymphatic transport when presented with an additional lymph load. This is also the case with the increased infiltrate that occurs in chronic venous hypertension, however the sustained infiltration requiring removal by the lymphatic vessels eventually results in the intact lymphatic system becoming overwhelmed (Mortimer 2000; Ramlett 2000).

This results in ‘high output failure’ of the lymphatic system, with structural and functional deterioration of the lymphatic vessels resulting in a further reduction in lymphatic transport capacity (Bernas et al 2001; Bollinger et al 1989). This has also been confirmed by lymphoscintigraphy, which has demonstrated a significant reduction in lymphatic function in oedematous compared to non-oedematous legs (Bull et al 1993). Raised venous pressures can also cause the capillary beds within the lymph nodes to switch from reabsorption to filtration (Levick 1991). Therefore lymph load is not reduced as it passes through the nodes, as the fluid that would have ordinarily been absorbed along the lymph node chains remains within the lymphatic vessels.

Changes that accompany chronic venous insufficiency

It is the continual stream of infiltrate and the decompensation of the lymphatic system which contributes to the oedema and progressive symptoms of lower limb chronic venous insufficiency. Invariably, the visual symptoms of this condition predominately manifest at the malleolar and calf regions, as these areas are the most distal and therefore experience the most hydrostatic venous pressure.

One of the earliest signs indicative of a failing lower limb venous system is visible venous dilatation. The sustained hydrostatic pressure in the system causes the veins to expand and become tortuous, this often first appears as dilated superficial veins in the malleolar area, which is commonly referred to as 'malleolar venous flare' and is indicative of mild chronic venous insufficiency. As the condition progresses, telangiectases (dilated intradermal venules), reticular veins (dilated subdermal veins) and varicosities also develop and become visible (Porter et al 1995).

As the venous insufficiency advances, the increased venous pressure transmitted to the subcutaneous capillary network results not only in dilation but also increased plasma and red cell exudation into the tissues. The degeneration of these red blood cells and organization of the exudated protein produces hyperpigmentation and eventual lipodermatosclerosis of the skin (Varma & Pappas 2004). The dermal fibrosis often seen in the later stages of CVI is associated with both protein production and transforming growth factor- β 1 gene expression which stimulates fibroblast collagen production in the subcutaneous tissue (Pappas et al 1999). An insoluble fibrin complex may also develop around the capillaries, resulting in

reduced oxygen and nutrient exchange between the microcirculation and the tissues (Strandness 1987; Browse & Burnand 1982).

This reduced exchange is also exacerbated by the chronic oedema which increases the interstitial diffusion distances for both the oxygen and cell nutrients (Mortimer & Levick 2004). A predisposition for capillary thrombosis also develops, which contributes to reduced functioning of nutritional skin capillaries and lower transcutaneous P_{O_2} (Nicolaidis 2000). All of these phenomena result in impaired cellular functioning and death, giving rise to the sequelae of late stage chronic insufficiency, such as varicose eczema, poor wound healing and venous ulceration.

Chronic venous insufficiency is both progressive and irreversible in nature, with research demonstrating that, as venous dysfunction and reflux increases, the clinical changes associated with the insufficiency increase in severity (Welch et al 1996; Van, Solomon & Christie 1994). This is also reflected in the CEAP classification of chronic lower extremity venous disease and insufficiency as established at the American Venous Forum in 1994 (Porter et al 1995). This classification is universally used in both the clinical and research setting and is outlined below;

C Clinical signs (graded 0-6) coded by (A) for asymptomatic and (S) for symptomatic (ie skin alterations and subjective symptoms – pain, aching etc).

Class 0: no visible or palpable sign of venous disease

Class 1: telangiectases, reticular veins, malleolar flare

Class 2: varicose veins (normally involving the great saphenous vein, anterior thigh circumflex vein or small saphenous vein).

Class 3: oedema without skin changes

Class 4: skin changes ascribed to venous disease (pigmentation, venous eczema, lipodermatosclerosis, atrophy blanche).

Class 5: skin changes as defined above but with healed ulceration

Class 6: skin changes as defined above but with active ulceration.

E Etiologic origin (congenital, primary, secondary)

A Anatomical distribution (superficial, deep, perforator or combination)

P Pathophysiological dysfunction (reflux or obstruction or combination)

The Impact of Limb Swelling Upon the Individual

Limb swelling, whether it be secondary to cancer treatment or venous insufficiency can have a profound and often negative impact upon the individual, due to its chronicity and requirement for ongoing maintenance. The swelling can decrease limb mobility, making it difficult to perform activities of daily living, with a study by Nicolaidis (2000) showing that chronic insufficiency significantly contributed to lost productivity and working days. A decrease in limb mobility and the distress associated with having such a condition can also have a detrimental effect on the person's quality of life, with studies showing that lymphoedema can impact upon both the person's mental health (Pereira de Godoy et al 2002; Casley-Smith 2001;) and job, leisure, sexual and social activities (Brenda 2001).

Chapter 2. The Assessment, Diagnosis and Treatment of the Lymphoedema or Venous Oedema Limb

Patient history and physical assessment

Before any therapy can be recommended and instigated for an oedematous limb, a thorough assessment needs to be undertaken to determine the nature and cause of the swelling. This will determine whether it is of lymphatic (primary or secondary), vascular or lipoedema origin or a combination of the aforementioned. The first step in this process is taking a full surgical and medical history. The surgical history helps to ascertain procedures which could have damaged lymphatic drainage (such as cancer treatment) or previous vascular surgery (such as vein stripping).

The medical history establishes past events such as deep vein thrombosis, family history of varicose veins or lymphatic disorders and co-morbidities such as heart failure, hypertension, vascular disease, hormonal imbalance/replacement, thyroid dysfunction, fluid retention and weight, which all could be increasing lymphatic load and hence exacerbating the condition. Most importantly the patient history should exclude tumor occurrence, which could be obstructing or invading proximal lymphatics (Bernas et al 2001), or deep vein thrombosis, which could be occluding venous drainage from the lower limb.

Once the patient's background history is established, the swollen limb should then be assessed. This normally starts with a general inspection and palpation to assess the state of the limb. This inspection helps to determine the presence of vein dilation and varicosities, pigmentation, limb shape, skin condition and/or infection and draws attention to areas that

will require management. Palpating the limb helps to determine how extensive the swelling is and whether it is in the pitting or non-pitting stage.

A further important diagnostic aid is the skin fold sign classed as the 'Stemmer sign'. This involves picking up and lightly pinching the cutaneous folds on the dorsum of the foot at the base of the big toe or on the dorsum of the hand, between the index and middle fingers. If the skin can not be lifted up and lightly pinched it is termed a 'positive' stemmer and indicates that lymphoedema is highly likely (Weissleder & Schuchhardt 2000; Stemmer 1976). In addition, the limb size and volume should be measured, with a circumference difference greater than 2.0 cm at any of the measured points along the limb, a limb volume change of greater than 200mls (or 10%) together with reported subjective symptoms leading to a diagnosis of clinically discernible lymphoedema (Harris 2001) or venous oedema (depending upon the underlying dysfunction). The accurate assessment of the swollen limb is vital for a correct diagnosis, for limb monitoring and creating and assessing the benefits of treatment regimes.

Limb Assessment

As accurate measurement of these conditions is so important, a number of measuring techniques have evolved which are used in the clinical and/or research setting to quantify the oedematous limb and to assess the impact it has upon the individual. Commonly used techniques are discussed below, whilst specialist techniques such as optoelectronic perometry, multi-frequency bioimpedance and tonometry will be discussed in the trial result section of this thesis.

Circumference

Circumference measurement using a tape measure is used in the clinical setting to measure total limb circumference. A non-elastic tape measure should be used, with the tape being held firm but not compressing the tissue and measurements always being taken from the same side of the tape. For limb measurement, the following protocol is usually followed (Reul-Hirche, Piller & Watkins 2001):

Arm

10cm, 20cm, 30cm, 40cm from the distal side of the ulna styloid process.

Hand: mid – point of the metacarpo-phalangeal hand joints (mid-hand).

Leg

10cm intervals from the sole of the foot to the top of thigh – up to 70cms.

Foot: mid-point of the metatarso-phalangeal joints (the toes)

mid-point of the tarso-metatarsal joints (mid-foot)

The 10cm distance interval is used for clinical monitoring of the limb, whilst most compression garment manufacturers use a 4cm interval for limb measurement.

Limb Volume

The measurement of limb volume is often seen as the most crucial component of limb assessment. In all limb volume measurements, regardless of the technique used it is important to consider hand and leg dominance, as this side can be slightly larger in size and volume in comparison to the non-dominant side. The other element to consider is those patients who have unilateral leg swelling subsequent to reproductive, urinary or gastrointestinal surgery. In these patients it can be difficult to ascertain whether the 'normal' contralateral side is indeed normal, as these surgical procedures can damage lymphatic pathways on both sides, therefore one leg can be severely affected and the other only mildly so (Stanton, Badger & Sitzia 2000). This problem can be overcome by taking a baseline measurement of the limbs before cancer treatment is instigated.

Using Tape measurement

Limb volume can be indirectly calculated from circumference measurements taken with a flexible tape measure. Measurements are made at 4cm intervals along the axis of the limb and then calculated using one of the following equations (Stanton et al 2000):

1. Truncated cone: $V_{\text{limb}} = \Sigma(X^2 + Y^2 + XY)/3\pi$

X is the circumference at one point on the limb, and Y is the circumference at a point 4cm up the limb from X.

2. Cylinder: $V_{\text{limb}} = \Sigma Z^2 / \pi$

Z is the circumference of the 4cm segment of the limb taken from the mid-point.

There is also an equation based upon a wedge shape for calculating foot volume, but this is not commonly used:

3. $V_{\text{foot}} = LCH / 2\pi$

L is the foot length, C is the ankle circumference, H is the foot height from the sole of the foot to where C is measured.

Accuracy of the tape measurement technique (and therefore the calculated volume) is reliant upon operator experience, accurate spacing of the tape measure, measurement at right angles and the tension upon the tape. Equations 1 and 2 are also based on the assumption that the limb is in the shape of a cone or cylinder, whilst other equations assume an ellipsoidal shape. It is possible that either can be used, as a study by Mayrovitz (2003) has shown that the difference in estimated limb volumes calculated by the circular and elliptic methods is less than 5%. Using a elliptical frustum model has also been shown to be useful in calculating hand volumes and correlates with volumes derived by the water displacement technique (Mayrovitz, Sims, Hill et al 2006). Converting circumferential measurements into limb volume is acknowledged as being difficult, due to oedematous limbs varying greatly in size and shape.

Using Water Displacement

This involves immersing the limb in a volumeter that consists of a water filled plexiglass cylinder. The water from the cylinder is displaced into a graduated receptacle from which limb volume can be determined, either through direct measurement or from the weighing of the displaced water. This method is considered to be a fairly accurate technique with an intra-observer reproducibility of 0.7% and an inter-individual variability of 1.3% (Perrin & Guex 2000). Limb volumes obtained from water displacement also correlate with volumes derived from circumferential tape measurements (Karges, Mark, Stikeleather & Worrell 2003).

However, this particular technique can be messy and can not be used in the post-op period, with those with restricted joint mobility or with skin disease due to the risk of cross infection (Stanton et al 2000).

Imaging

Magnetic Resonance Imaging (MRI)

MRI can visualize lymph trunks, lymphatic transport, lymph nodes and soft tissue proximal to sites of lymphatic destruction. It can also demonstrate the changes that occur in the lymphoedematous limb, such as diffuse subcutaneous oedema, increased subcutaneous fat and channels consistent with dermal collateral lymphangiectasis (Hwang et al 1999; Case, Witte, Witte et al 1992).

Computerized Tomography Scanning (CT Scan) and ultrasound

CT scans take cross-sectional measurements of the whole limb providing information on the muscle and subcutaneous compartments. In lymphoedema it has demonstrated skin thickening and the increase in volume of the subcutaneous compartment, with the muscle compartment remaining relatively unaffected (Stanton et al 2000). Ultrasound is also considered to be a useful clinical tool in assessing lymphoedema (Mellor, Bush, Stanton et al 2004; Tiwari, Cheng, Button et al 2003), as it can assess tissue compositional changes plus skin and subcutaneous thickness.

However, the aforementioned imaging techniques are not always routinely used in the clinical setting due to the cost (especially if repeated measurements are required), the equipment and the expertise required. In most cases the majority of information about the oedematous limb can be gathered through the patient history and routine measurement techniques.

Limb Lymphatic Function

Lymphography

Contrast or isotope lymphography (also known as isotope lymphoscintigraphy) is sometimes used to diagnose lymphoedema as it demonstrates the filling of the initial lymphatics and lymph collectors (Partsch 2003), helping to determine the presence of lymphatic dysfunction. A study by Burnand et al (2002) using isotope lymphography has concluded that although this is a moderately sensitive test for lymphoedema, it may sometimes lead to normal legs being mistakenly classified as lymphoedematous. However, the newer technique of interstitial

magnetic resonance lymphography holds promise in the mapping of lymphatic drainage and disturbed lymphatic flow (Suga, Yuan, Ogasawara et al 2003).

Lymphoscintigraphy

This is a more routinely used diagnostic test in patients with suspected lymphoedema as it evaluates lymphatic transport and reliably depicts abnormalities in the lymphatic circulation (Bernas et al 2001; Witte & Witte 1999; Cambria et al 1993). In particular, the injected intracutaneous radioisotope and the subsequent images taken by the gamma camera can show dermal diffusion (backflow), retrograde tracer backflow (reflux) and regions with poorly filled or absent lymph nodes (Case et al 1992). The images can also help to discriminate between oedema of lymphatic and non-lymphatic origin (Proby, Gane, Joesph & Mortimer 1990).

Again due to the cost, equipment and expertise required for this technique, it is not always used as the first line of assessment in the clinical setting. Instead, it is more likely to be used in scenarios where the patient history is complex (and therefore a straight forward diagnosis of lymphoedema is not possible) or to determine why a particular patient has not responded to routine treatment.

Leg Venous Function

Venous Doppler

Venous doppler allows the study of the physiology, anatomy and flow of the lower limb venous system. It can be used to confirm the presence of varicose veins (Safar, Shawa, Al-Ali et al 2004), to evaluate the competence of the sapheno-femoral and sapheno-popliteal junctions (by employing the Valsalva manoeuvre which will cause retrograde blood flow) and the presence of incompetent perforators by applying a light tourniquet proximal to the probe and releasing it (Porter et al 1995; Villavicencio et al 1989).

Duplex ultrasound

Duplex ultrasound uses high frequency ultrasound waves to image the blood vessels and surrounding tissue and in the establishment and quantification of blood flow direction (Van Bemmelen et al 2002; Porter et al 1995). It is also used in the diagnosis of deep vein thrombosis (Chan, Chiu, Cheng & Ho 2004) and saphenous vein reflux (Lin, Iafrati, O'Donnell et al 2004). When used in combination with plethysmographic methods, a quantitative and qualitative assessment of the venous system and where it may be failing can be achieved (Kerr, Watson & Dalsing 2004).

Air plethysmography

This is a non invasive way of establishing superficial or deep chronic venous insufficiency (Frullini, Weiss & Schadeck 2001; Villavicencio et al 1989), venous obstruction, valve incompetence or calf muscle pump dysfunction (Perrin & Guex 1995; Porter et al 1995). It consists of a tubular air chamber that envelops the lower leg (ankle to below the knee) which

is connected to a pressure transducer and chart recorder (Christopoulos et al 1987). This technique provides information on leg volume changes, venous ejection fraction and residual venous volume.

Phlebography and varicography

Phlebography is not commonly used in the clinical setting, as sonographic Doppler and Duplex techniques are now used to visualize the lower limb venous systems (Weber 2001). Both of these methods involve the injection of dye into the venous system and are used to assess cases of recurrent varicose veins, deep vein thrombosis, postphlebotic syndrome and complex problems with unclear clinical manifestations (Antoch, Pourhassan, Hansen & Stock 2002; Markovic, Baskot, Ajdinovic 2001; Villavicencio et al 1989). In particular, ascending varicography (or venography) can be used to identify areas of venous obstruction, recanalization and collateral vein formation and incompetent sapheno-femoral and sapheno-popliteal communications (Phillips, Paige & Molan 1995; Porter et al 1995).

Lymphoscintigraphy

Lymphoscintigraphy can also be used to determine the deleterious effects the venous insufficiency is having on the lymphatic system. A study by Brautigam et al (1998) demonstrated that patients with cyclic idiopathic oedema had an accelerated rate of lymphatic transport (high volume overload or dynamic insufficiency), those with venous (phlebo) oedemas had a high volume lymphatic overload of the epifascial compartment, whilst patients with post thrombotic syndrome had reduced subfascial lymphatic transport.

Limb Range of Movement

Both surgical scarring and limb swelling can have a detrimental impact upon limb range of movement, which can be objectively assessed by a manual or electronic goniometer, which reliably assesses joint angles and degrees of limb movement (Legnani, Zappa & Casolo 2000; McCulley 1999). Subjectively, the patient maybe asked to lift, bend or rotate the leg or to lift the arms straight above the head so that the clinician can visually ascertain problems with range of movement. Grip and muscle strength may also be assessed to ascertain whether the limb swelling has had an adverse effect on these parameters. These tests are performed with a dynamometer, which is considered a reliable way of determining hand grip strength, muscle strength and fatigue (Watanabe, Owashi, Kanauchi et al 2005; Schreuders, Roebroek, Jaquet et al 2004; Surakka, Romberg, Ruutiainen et al 2004).

Subjective Symptoms & Quality of Life

Commonly reported symptoms associated with lymphoedema or venous insufficiency, such as pain or aching, heaviness, tightness, burning or bursting sensations, cramps (more common in CVI) and perceived limb size difference can be rated on validated rating scales such as the Likert or Visual Analogue Scales to assess severity. It is also important to differentiate these symptoms from those caused by the initial surgery, such as numbness and tingling sensations.

The impact of the lymphoedema or oedema on the patient's quality of life and ability to perform activities of daily living can be assessed and rated using a lymphoedema specific questionnaire such as the FACT-B + 4 for arm lymphoedema secondary to breast cancer treatment (Coster, Poole & Fallowfield 2001) or the Chronic Venous Insufficiency

Questionnaire (CIVIQ) for those with venous insufficiency and oedema (Launois, Reboul-Marty & Henry 1996). Alternatively, generic questionnaires such as the McGill Quality of Life questionnaire or Short Form-36 (SF-36) (Azevedo et al 2001) may also be used.

The Importance of Treatment and Management of the Lymphoedema or Venous Oedema Limb

Once the diagnosis of secondary lymphoedema or oedema due to vascular insufficiency is established and the state of the limb is known, it is imperative that some form of therapy is implemented. The importance of treatment and management, whether it is active, maintenance (or both) cannot be underestimated, as both lymphoedema and oedema are chronic conditions which if left unattended and untreated (or inappropriately treated), will worsen over time.

Research data collected over both the short and long term supports both the progressive nature and treatment need of these conditions. Data from Casley-Smith & Casley-Smith (1997) on 231 people with unilateral arm lymphoedema and 177 people with unilateral leg lymphoedema demonstrates that over time (up to 50 years duration) the amount of lymphoedema increases and that the limb progresses from lower to higher grades of classification.

Short term research studies which include control groups also demonstrate these trends. A study by Box et al (2004) included a control group who were followed over 10 weeks. By the tenth week the arm volume in the control group had increased by 32.5mls (~ 3.2%) in comparison to the treatment group who had had volume reductions at this time point. This is in concert with a handheld laser study by Carati et al (2003) where the placebo group experienced an increase in volume of 30mls (~ 3.0%) at 3 months follow up compared to the treatment groups who had reductions at this time point.

A study by Cluzan et al (1996) included a control group which demonstrated a 2.5% increase in oedema (~ 25mls) after 2 months of not receiving treatment. This is in comparison to the treatment group which had a decrease of 12.9% (~ 130mls). Control groups followed over a 6 month time frame by Loprinzi et al (1999) and Pecking et al (1997) have demonstrated increases in arm volume of 21mls (~ 2.2%) and 10% (~ 100mls) respectively. The biggest increase in limb volume was recorded by Casley-Smith et al (1993), where the control group increased in limb volume by 490mls (41.6% in oedema) over a 12 month period.

Studies involving patients with oedema subsequent to chronic insufficiency also demonstrate this trend. A study by Knocker et al (1999) demonstrated that the placebo group increased in leg volume by 4mls (1%; n.s.) whilst the treatment groups lost on average 11mls (~ 1.5%) over a 3 month period. The treatment groups also experienced a statistically significant reduction in subjective symptoms in comparison to the placebo group. These results are in unison with a study by Casley-Smith (1998), which showed that the control group had an increase in leg volume of 4mls (~ 1%; n.s.) and no improvements in subjective symptoms after 6 weeks, this is contrast to the treatment group which had a significant limb reduction of 81mls (~ 8.4%) and improvements in subjective symptoms.

Lastly, a study by Diehm et al (1996) demonstrated an increase in leg volume of 9.8mls (~1%) in the placebo group over 12 weeks in comparison to the treatment groups who lost on average 45mls (~ 4.4%, $p < 0.01$ in comparison to placebo). Although the volume increases are small, all of the aforementioned studies demonstrate the same and consistent pattern, with two studies also showing no improvements in subjective symptoms when no treatment is instigated. Again, this reinforces the need for appropriate and ongoing treatment regimes for these patient populations.

Treatments for the Lymphoedema or Venous Oedema Limb

Currently, there is no cure for secondary lymphoedema or oedema of vascular origin, therefore existing treatment regimes aim for limb volume or size reduction, infection minimization and improvements in cosmesis, limb function and quality of life. Commonly recommended and instigated regimes for limb lymphoedema include; complex physical/decongestive therapy, manual lymphatic drainage, self and/or partner massage, limb elevation and exercise, compression bandaging and garments, pneumatic pumps, laser therapy and pharmacological oral preparations. Whilst all these therapies may also be beneficial for oedema of vascular origin, the most predominant therapies include leg elevation and isotonic or isometric exercise, compression garments and pharmacological oral preparations. All these therapies will be systematically reviewed in the following chapter, the role of peripheral therapies (those not widely used in oedema management), sclerotherapy, laser therapy and surgery in these conditions is discussed below.

Peripheral Therapies

Therapies such as thermal, microwave, vibrational and ultrasound therapy have been researched but are not commonly used as therapy in most countries. Microwave therapy alone and in combination with compression and oral 5,6 Benzo-[alpha]-pyrone has been shown to reduce oedema and improve the signs and symptoms of lymphoedema (Chang, Gan, Fu & Huang 1996; Chang, Han, Gan & Huang 1989). Whilst Ohkuma (1992) found that the most benefits from microwave therapy plus compression bandaging were derived when applied in the earlier (fluid) stage of the lymphoedema.

Okuma (2002) has also studied vibrational therapy in combination with hyperthermia and magnetic fields and found in a small sample of patients (n = 8) that it reduced the lymphoedematous limb. Piller, Merritt, Esterman & Moseley (2004) have also found that a vibrational massage pad reduces leg oedema and improves quality of life. The use of multi-directional vibration therapy has also been shown to accelerate lymph vessel regeneration and reduce localised oedema in rat models (Leduc, Lievens & Dewald 1981). A pilot study by Balzarini et al (1993) investigating the benefits of ultrasound on secondary arm lymphoedema found a reduction in arm volume and tissue softening after 4 months of treatment. Additional research into these therapies to ascertain their exact benefits is warranted, with the International Society of Lymphology consensus document stating that their current role in lymphoedema management remains “unclear” (Bernas et al 2001).

Another procedure which holds promise but which also requires further research is the injection of autologous lymphocytes into the artery of the affected limb. It is hypothesised that the introduced lymphocytes stimulate macrophage proteolysis, aiding the removal of the excess interstitial protein and therefore helping to relieve the oedema (Knight, Ritz, Lepore et al 1994). Preliminary trials have shown that this procedure reduces limb volume and improves limb condition, both alone (Nagata, Murata, Mitsumori et al 1994) and in combination with the wearing of a compression garment (Ogawa, Yoshizumi, Kitagawa et al 1999).

Surgery for Limb Lymphoedema

Due to the invasive nature and the associated risks of surgery, it is generally only considered in cases where lymphatic patency is likely to be restored or in severe lymphoedema, where conservative therapies (the focus of this thesis) have not been beneficial in terms of limb reduction, cosmesis and symptomology. Various surgical techniques have been developed and used over the years to help reduce the oedematous limb, with mixed results.

Surgical Anastomoses

This involves the use of lymphatic to lymphatic, lymph node to lymphatic or lymphatic to venous anastomoses to bridge the local blockage and therefore restore transport capacity. It has been suggested that this type of surgical technique may be most beneficial prophylactically, to help maintain lymphatic patency and therefore prevent the development of overt lymphoedema (Clodius 1982).

These types of anastomoses have been shown to re-establish continuity in dog models (Chen et al 1990) and to reduce limb volume and improve subjective symptoms in patients, with a percentage of these reductions being maintained over a 3-7 year period (Campisi Boccardo, Zilli et al 2001; Baumeister & Siuda 1990; O'Brien et al 1990). Campisi et al (2001) also found limb softening and a reduction in cellulitis incidence when using these surgical techniques. In contrast to these results, Vignes et al (2003) found that lympho-venous anastomosis failed to improve lower limb volume and to reduce the frequency of cellulitis in a small sample (n = 13) of lymphoedema patients.

Excisional Operations

This operation, commonly referred to as the 'Charles Procedure' in honour of the Surgeon who developed it, reduces limb volume by the staged resection of the subcutaneous tissue with the remaining deficit being covered by skin grafts. Various modifications of this technique also exist, including the 'Sistrunk', 'Kondoleon' and 'Thompson'. Good results in terms of improved limb function, contour, and reduction in the incidence of cellulitis have been reported for this type of operation (Miller, Wyatt & Rudkin 1998; Kim et al 1996; Song, Gao, Li & Zuo 1982). However, excisional surgery as a treatment option does need to be carefully considered, as complications can include poor wound healing and infection (as the lymphatic system is already compromised), sensory nerve loss, residual oedema of the foot or ankle, surgical scarring and poor cosmetic results (Tiwari et al 2003; Gloviczki 1999).

Liposuction

A newer form of surgery for limb lymphoedema is liposuction. Traditionally it was believed that this type of surgery could cause trauma to the lymphatic vessels and therefore contribute to the decreased transport capacity in the already compromised system. However, a prospective study by Brorson et al (1998) using combined liposuction with controlled compression therapy in 20 secondary arm lymphedema patients resulted in a 115% volume reduction with no new damage or impairment to lymph transport (as detected by lymphoscintigraphy). Brorson (2003) also found that the oedema had not reoccurred at 7 year follow up in those who were compliant with wearing a compression garment.

A study by Hoffmann, Fertmann, Baumeister et al (2004) has also concluded that tumescent liposuction, which involves the infusion of local anaesthetic and epinephrine into the tissue followed by subcutaneous fat removal (Lindenblatt, Belusa, Tiefenbach et al 2004) is unlikely to cause major lesions to epifascial lymph vessels if the suction procedures are performed at right angles to the extremity axis.

Treatments for Chronic Venous Insufficiency of the Lower Limb

Sclerotherapy & Laser Therapy

Sclerotherapy involves the injection of a caustic sclerosing agent directly into the dysfunctional vein with the aim of collapsing the lumen through endothelial damage, inflammation and scarring (Frullini et al 2001; Villavicencio 2001). During this procedure extravasation of the agent into the surrounding tissue must be avoided, as it can result in skin or fat necrosis, ulceration or hyperpigmentation (Kerr, Watson & Dalsing 2004).

Sclerotherapy is predominately used to treat varicose veins (Tisi & Beverley 2002; Villavicencio et al 1989), with a randomised controlled trial by Kahle & Leng (2004) demonstrating that limb hemodynamics were improved after this procedure. Other authors have also reported benefits in treating sapheno-femoral or sapheno-popliteal reflux (Clements 2001), incompetent venous perforators and vascular malformations (Villavicencio et al 1989).

Endovenous laser is also used to occlude dysfunctional veins and is predominantly used in the treatment of primary varicosities. Short and intermediate-term outcomes have shown that this procedure is comparable to surgical stripping in terms of venous reflux elimination, resolution of visible varices and improvements in subjective complaints (Kluner, Fischer, Filimonow et al 2005). Patient satisfaction with laser therapy is also generally higher, as there is minimal discomfort and the duration of treatment and recovery is shorter (Sadick 2005).

Vein Stripping and Perforator Vein Ligation

When sclerotherapy and laser therapy of varicose veins fails, the segments containing the varicosities are sometimes surgically removed or 'stripped' via incisions and the use of a fine flexible wire to extract the vein. The most commonly removed veins are the saphenous veins from the groin to the knee and from the knee to the ankle (Kerr, Watson & Dalsing 2004). Although studies have shown that this procedure improves deep reflux (Ciostek, Michalak & Noszczyk 2004), post operative complications can be significant in terms of nerve damage, wound infection and scarring (Frulleni et al 2001). In particular, this procedure may cause damage to the local lymphatic vessels, which may contribute to the development of lymphoedema (Balzer & Schonebeck 1993).

Direct surgical ligation of incompetent perforating veins can be performed alone or in conjunction with vein stripping. This technique helps to re-route venous flow to more competent perforators and has been shown to successfully reduce the symptoms of venous incompetence and to contribute to the healing of venous ulcers (Lasheen, Hefny, El Askry et al 2004; Gloviczki, Bergan, Rhodes et al 1999).

Venous Bypass and Valve Repair/Replacement

Venous bypass or stenting is used to decompress or circumvent certain segments of the venous system. A segment of native vein (normally the saphenous) or polytetrafluoroethylene graft material is used to bypass the diseased distal vein by connecting it to a disease free proximal vein (Kerr, Watson & Dalsing 2004). This type of procedure has been shown to improve symptoms of venous occlusive disease such as oedema and pain (Raju, Owen & Neglen 2001 & 2002).

Valve repair, which involves suturing the incompetent valves to tighten and reinforce them (Kerr, Watson & Dalsing 2004), is generally performed for primary deep venous valve incompetence. In situations where this procedure fails or where the valve is beyond repair, it may be replaced. This involves replacing the incompetent valve with one that is functional and can protect against reflux. The replacement valves themselves can be either autogenous (normally taken from the upper extremity) or prosthetic, with both forms being shown to improve competence (Jessup & Lane 1988) and to reduce symptoms such as pain, swelling, cramps and skin pigmentation (Lane, Cuzzilla & McMahon 2003). One of the drawbacks of this surgical technique is that the transplanted valve can become incompetent over time (Bry, Muto & O'Donnell 1995) resulting in the return of the venous reflux.

The Important Role of Exercise for the Lymphoedema or Venous Oedema Limb

The effect of exercise on the lymphatic system was first studied in animals, with exercise of both short and long duration being shown to increase lymphatic contraction frequency and lymph flow (Coates, O'Brodivich & Goeree 1993; McGeown, McHale & Thornbury 1987). The positive influence of muscle activity on the lymphatic system is explained by experiments undertaken by Mazzoni et al (1990) on the spinotrapezius muscle of rats. This research demonstrated that the stretched skeletal muscles pulled on the anchoring filaments joined to the initial lymphatics, helping fluid to move into the vessel. When the muscle was then contracted, the increase in the muscle fiber cross-section compressed the connective tissue and therefore the lymphatics, resulting in lymph being pushed towards the lymph collectors.

The positive effects of exercise on lymphatic function also been demonstrated in human studies, with a study by Havas et al (2000) finding that 2 hours of steady state exercise increased lymph clearance rate 5 fold in the first 15 minutes, whilst the rest of the time it was increased 2-3 fold. This increase in clearance is also in concert with a recent study by Lane, Worsley & McKenzie (2005), which demonstrated increased lymphatic clearance in the hand of healthy females who performed arm crank ergometry over 5 minutes. It is also known that exercise can enhance sympathetic activation, which in turn may increase the contraction of lymphatic collector smooth lining, which is also modulated by sympathetic activation (McHale & Roddie 1983).

These outcomes, when combined with those of animal studies demonstrate how exercise varies interstitial tissue pressure and influences both lymph propulsion and clearance. This not only helps in the transport of fluid but also inflammatory proteins (Olszewski & Engeset 1998; Havas et al 1997). Deep breathing, which changes inter-thoracic pressure and is sometimes incorporated into exercise programs, has also been shown to propel lymph centrally for drainage into the thoracic lymphatic ducts (Shields 1980) and to positively influence venous return (Sumner 1995).

Exercise has also been shown to be beneficial for those with chronic venous insufficiency of the lower limbs, as the muscular activity influences both the superficial venous flow (via the perforating veins) and the deeper venous system (via the larger saohenous veins). A study by Ciocon, Galindo-Ciocon & Galindo (1995) found that leg exercises undertaken over a 6 week period resulted in a statistically significant reduction ($p < 0.001$) in oedema. Another study which investigated a physical exercise program over 6 weeks found a significant ($p < 0.05$) increase in venous ejection fraction and decreased residual fraction in the affected limb (Yang, Vandongen & Stacey 1999). This is also supported by a randomised controlled trial by Padberg, Johnston & Sisto (2004) who found significant improvements in these parameters after 6 months of performing an exercise program.

Exercise also has secondary benefits, including the maintenance of limb flexibility and range of movement (Kahn et al 2001; Brennan and Miller 1998), combating the harmful effects of chemotherapy and radiotherapy on the cardiovascular system (Miller 1996), improving general well being (McKenzie and Kalda 2003) and body weight maintenance. The maintenance of body weight is particularly important as being over weight results in more adipose tissue for the initial lymphatics to drain. Excess abdominal fat can also exert a downward pressure on both the groin lymphatic vessels and veins, putting an additional load

on the already compromised lymphatic and /or vascular system. Obesity has also been shown to increase the incidence of cellulitis in those with lymphoedema (Herbertz 1998).

The benefits of exercise for those who have limb swelling from either lymphatic or venous dysfunction should not be underestimated. Considering this and the potential ease in which it can be utilized in limb maintenance, it is surprising that exercise has not attracted more research. The following systematic review will compare and contrast the benefits of commonly instigated conservative therapies for limb oedemas, including the benefits of exercise. This will be followed by an exploration (via clinical trials) of the benefits of different exercise regimes for secondary limb lymphoedema and lower limb venous oedema.

Chapter 3. Systematic review of the effectiveness of commonly recommended conservative therapies for secondary limb lymphoedema and oedema of the legs.

This systematic review has been undertaken adopting the style used by the Cochrane Collaboration. Traditionally with this style a background section would be presented, but as this has already been done in chapters one and two, it has been omitted.

Synopsis

Currently there is inadequate scientific evidence from well controlled studies to make evidence based recommendations as to which conservative therapy is the most effective for secondary lymphoedema and oedema of vascular origin. However, this review has shown that varying benefits can be derived from treatments instigated by health professionals, including complex physical therapy, manual lymphatic drainage with or without compression, laser therapy, low pressure pneumatic pump therapy, and oral pharmaceuticals. These benefits included reduction of limb volume and/or oedema fluid and improvements in subjective symptoms and quality of life. Self maintenance programs, including limb exercises, elevation, self and/or partner massage and the wearing of compression garments resulted in smaller improvements but provide a beneficial adjunct to health professional based therapies. Despite this range of positive outcomes, there is still a need for well designed, large scale clinical trials in this area.

Objectives

The overall objective of this review was to systematically assess the effectiveness of a range of existing conservative therapies for secondary lymphoedema of the limbs and oedema of the legs subsequent to chronic venous insufficiency.

Specifically the objectives were:

1. To assess the effect of conservative therapies on limb volume, limb tissue softening and subjective symptoms.
2. To assess the effect of conservative therapies on quality of life and activities of daily living.
3. To give an estimate of the effectiveness of the conservative therapies.

Review Method

Types of Studies

Currently, there are only a small number of randomized controlled trials in lymphoedema/oedema therapy research; therefore this review also included studies performed in the parallel and cross-over format plus case control and cohort studies, all of which underwent a narrative review process. Case studies and anecdotal evidence were not reviewed.

Types of Participants

Participants involved in the reviewed studies were as follows:

- Adults (> 18yrs of age)
- Those who received lymphoedema/oedema therapy in a hospital, community or home setting.

Inclusion Criteria

Secondary lymphoedema of the limbs

- Those with diagnosed secondary lymphoedema subsequent to cancer treatment (surgery ± radiotherapy ± chemotherapy) for mammary, integumentary, gastrointestinal, urinary or reproductive cancers.
- Those who have a difference greater than 2.0cm at any of the measured points along the limb, a volume change of greater than 200mls and reported subjective symptoms, as these three criteria are regarded as clinically discernible lymphoedema (Harris 2001).
- Those who have no evidence of recurrent cancer.

Oedema of the Leg/s

- Those with diagnosed chronic venous insufficiency (congenital, primary, secondary) with manifest leg oedema as measured by tape measurement, water displacement or tape measurement.
- Those with a CEAP classification of 3 - 6, classification 3 being oedema without skin changes through to 6 which is oedema with skin changes and active ulceration (Porter & Moneta 1995).

Exclusion Criteria

Secondary lymphoedema of the limbs

- Those with secondary lymphoedema as a consequence of diagnosed filariasis and those with a diagnosis of primary lymphoedema or limb lipoedema were excluded.

Oedema of the Leg/s

- Those with leg swelling related to diagnosed chronic cardiac, hepatic or kidney failure or other medical conditions which could cause fluid retention were excluded.

N.B. When studies included different patient populations, only the results of the patient population(s) that fitted the inclusion criteria were reviewed.

Types of Interventions

- ***Combined Decongestive Therapy or Complete Physical Therapy or Complex Physical Therapy:*** this therapy was first instigated in the 1930's by Emil Vodder, who created a specific massage (manual lymphatic drainage) which involved a combination of light hand pumping and circulating motions to decongest the swollen limb and its accompanying lymph nodes (Wittlinger & Wittlinger 1998). He also found that the application of compression bandaging to the limb helped to maintain this decongestion (Wittlinger 2003). Today, the name of this particular therapy varies from country to country, but the core components remain the same. These include daily manual lymphatic drainage followed by compression bandaging (administered by a health professional) and skincare plus prescribed limb exercises undertaken by the patient. The therapy is usually administered over a 2 – 4 week period, as an in or out patient service, after which time the patient is fitted with a compression garment.

The implementation of skincare is particularly important, both in this therapy and generally, as the oedema alters skin nutrition and immune responses which provide an ideal opportunity for bacterial entry and subsequent infection (cellulitis). Skincare of the limb encompasses daily moisturizing, the treatment of skin trauma with powdered or liquid antiseptics and the treatment of conditions such as eczema, dermatitis, papillomatomas and fungal infections (Marsch 2005).

- ***Manual Lymphatic Drainage:*** this is a specific form of massage that aims to remove a component of the excess fluid from the interstitial space by varying total tissue pressure, encourage new lymphatic pathways, increase lymphatic transport and soften fibrotic induration in the affected limb (Mortimer 1995; Földi, Földi & Weissleder 1985). All methods start by clearing the areas distance or adjacent to the affected limb before moving to the root of the limb then to it's most distal section.

However, there are varying techniques for this form of massage according to how the therapist is trained. Specifically, the 'Dr Vodder' method pushes and stretches the skin using a light pressure (Kasseroller 1998; Wittlinger & Wittlinger 1998), whilst the massage techniques used in the 'Földi' clinic (Germany) incorporates stationary circular motions, rotary, pump and scooping techniques (Földi, Földi & Kubik 2003). The 'Leduc' method advocates an individualised approach with the use of superficial and soft manipulation (Leduc, Leduc, Bourgeois & Belgrado 1998), whilst the 'Casley-Smith' method uses nodal massage, scooping and stroking techniques (Casley-Smith & Casley-Smith 1997). The type of massage used when treating patients varies depending upon which country it is practice and/or where the therapist was trained.

As the initial lymphatic capillaries and the lymphatic collectors are delicate in nature, it is important that this type of massage is not too forceful, as high pressure (70-100mmHg) massage has been shown to cause damage to both the lymphatic capillaries and collectors (Bernas et al 2001; Eliska & Eliskova 1995).

- ***Self/partner massage:*** health professionals teach patients or their significant other a simplified version of manual lymphatic drainage (Piller, Packer, Coffee & Swagemakers 1996) which includes clearing of the adjacent area and limb root followed by sweeping strokes over the limb itself. It is important that the patient/significant is trained in the technique by a qualified professional/therapist and that the patient has regular check ups with a health professional to monitor the limb's response to the massage.

- ***Compression (multi-layering) bandaging:*** compression bandaging is often applied after other therapies (such as manual lymphatic drainage) with the aim of maintaining the achieved volume reduction. In lymphoedema management, the bandaging consists of a multi-layer system which includes a gauze sleeve which protects the skin, soft cotton wrap or high density foam and 2-3 layers of short-stretch bandaging. The pressure applied by the bandaging should be high enough to be effective but should not cause restricted circulation or pain (Strössenreuther 2003).

This form of compression may help to reduce and/or maintain the swollen limb by decreasing the amount of interstitial fluid formation, preventing lymph and blood back flow and enhancing the muscle pump by providing an inelastic barrier for the muscle to work against (Yasuhara, Shigematsue & Muto 1996). The combination of compression bandages and muscle activity has also been shown to improve the reabsorption of colloid proteins (Leduc, Bourgeois, Peters & Leduc 1990). A four layer compression system is also used on patients with chronic venous insufficiency, especially those with venous ulcers. This type of compression lowers venous hypertension by improving ejection fraction and venous flow (Van Geest et al 2000; Christopoulos et al 1987), which results in less venous reflux (Spence & Cahall 1996).

- **Compression garments:** compression garments have a similar mode of action as compression bandaging, that is, the reduction of tissue infiltrate and providing a barrier for the muscle pump to work against. Garments can be measured and fitted individually to the swollen limb by a health professional or purchased on a ‘off the shelf’ basis from garment manufacturers, medical supply companies or pharmacies. It is important that great care is taken in the measuring of a compression garment, as an ill fitting garment can cause a tourniquet effect, which may slow fluid drainage through the lymphatic and vascular systems. In the longer term this can cause the build up of a proximal fibrotic band (Casley-Smith & Casley Smith 1997), which may further impede lymphatic flow from the limb.

The compression applied to the limb is intended to be graduated, with the greatest compression being at the distal end of the limb and the least amount being at the proximal end. The class of compression ranges from 1 (lightest) to 4 (heaviest) but there is currently no uniform international standards for these compression classes, therefore the type of pressure (mmHg) exerted on the limb within each class varies from country to country. In particular, Britain, France and Germany have developed their own standards for these classes, whilst the United States of America and Australian have not developed national standards.

Contraindications for all forms of compression include; impaired arterial flow, infections, decompensated cardiac failure, diabetic neuropathy, brachial index < 0.6 and microangiopathy (Fullini et al 2001).

- ***Limb exercises:*** exercise regimes which can be progressive, resistive or sequential in nature are often recommended by health professionals as a way of varying total tissue pressure in the limb to encourage lymphatic and venous drainage. Exercise can also improve limb range of movement and limb strength (Johansson, Tibe, Kanne & Skantz 2004) and general well being (Sandel, Judge, Landry et al 2005; Box, Marnes & Robertson 2004).

- ***Elevation:*** Elevation of the limb is advocated to reduce capillary exudation and to promote both venous and lymphatic return. Elevation is considered most useful in the earlier (fluid) stage of lymphedema (Bernas et al 2001; Swedborg, Norrefalk, Piller & Asard 1993), with it's effectiveness becoming less as the lymphoedema progresses and becomes more fibrotic and fatty in nature. Elevation has also been shown to be beneficial in those who have limb oedema due to chronic venous insufficiency (Xia et al 2004).

- ***Pneumatic pump therapy:*** These are single or multiple chambered pumps that can be administered by health care professionals in a clinical setting or the patient in the home environment. The number of pump chambers utilised can be up to eleven, with claims of greater outcomes with larger numbers of chambers (Bergen et al 1998; Zelikovski et al 1980). Traditionally, the pneumatic pumps used applied the same pressure gradient along the entire limb and pressures of up to 150mmHg where administered. The newer pneumatic pumps administer a gradient pressure in the range of 30-80mmHg (with the greatest pressure applied around the distal end of the limb and the least around the proximal end – refer to table 3.6). Once the limb is enveloped in the pump, it inflates and deflates at different cycles and pressures to encourage fluid drainage from the distal to the proximal end of the limb (Brenan & Miller 1998).

There is a current debate as to whether this form of therapy removes fluid from the limb via the venous system (Dereppe, Hoylaerts, Renard et al 1990) or whether there is the risk of displacing the oedema to more proximal areas of the limb or into the genitalia (Boris, Weidorf & Lasinski 1998). There is also concern over the development of fibrosclerotic bands around the top of the extremity (Bernas et al 2001), which may actually impede lymphatic flow. It is important that health professionals are aware of these potential risks and that massage is administered to the adjacent area and proximal end of the limb (so these areas are cleared) before the pump therapy is applied.

There are a number of contraindications for complex physical therapy, manual lymphatic drainage and pneumatic pump therapy, these include:

- Congestive cardiac failure (since the therapies can shift significant amounts of fluid from the extracellular space and therefore put an extra load on the already failing heart).
- Acute deep vein thrombosis (therapies may dislodge the clot).
- Limb infection or inflammation (risk of spreading the bacteria and infection).
- Active malignancy (it is theorised that the therapies may spread cancer to other sites through the lymphatic system). This recommendation is currently under debate in the application of CPT and MLD, however, it is generally only applied to patients who are classified as palliative. The palliation of lymphoedema related to overt tumour blockage is supported by the International Society Consensus document (2003).

- ***Low level laser therapy:*** laser therapy uses low intensity wave lengths between 650 – 1,000nm, either in a scanning form which moves up and down the limb, or in a spot laser form to concentrate the beam in particular areas (such as scarring, the groin or axilla). Research suggests that laser therapy increases the rate of lymph vessel pumping (when this is decreased), promotes lymph vessel regeneration (Lievens 1985 & 1991), reduces pain (Nakaji, Shiroto, Yodono et al 2005) and softens both fibrous tissue and surgical scarring (Nouri et al 2003).

- ***Oral pharmaceuticals:*** oral diuretics are often prescribed for leg oedema that results from chronic venous insufficiency. These preparations reduce microcirculatory leakage into the interstitium by blocking water reabsorption in the nephrons and therefore lowering circulating blood volume (Mortimer & Levick 2004). However, diuretics are believed to be of little benefit in lymphoedema, as they remove the fluid but not the protein content of the swelling (Campisi, Michelini & Boccardo 2004). This subsequently results in a higher osmotic pressure in the tissues, resulting in fluid return. Prolonged use of this category of drugs may also result in fluid and electrolyte imbalances (Bernas et al 2001) and haemoconcentration of the blood, which can increase the risk of deep vein thrombosis (Cheatle, Scurr & Coleridge-Smith 1991).

The most common oral pharmaceuticals used in the treatment of both lymphoedema and oedema of vascular origin come from the Benzopyrone family and can be separated into the alpha (α) Benzopyrones such as the Coumarin derivatives and the gamma (γ) Benzopyrones such as the flavones and flavonols (Ramalet 2000). Commonly used preparations include MPFF-Micronized Purified Flavanoid Fraction (Daflon[®]), Oxerutins (Paroven[®], Venorutin[®]), Escins, also known as ‘horse chestnut’ (Venastat[®], Reparil[®]),

Ruscogenin combined with Hesperidin (Cyclo 3 Fort[®]) and Coumarins (5,6 Benzo- α -pyrone, Lodema[®]) (Badger et al 2003). The most commonly reported side-effect for this category of oral pharmaceuticals is gastrointestinal upset (Casley-Smith, Morgan & Piller 1993; Wadworth & Faulds 1992).

Coumarin (Lodema[®]), which is used in lymphoedema management in overseas countries, was withdrawn from the Australian market by the Therapeutic Goods Administration in August 1996. This was due to liver toxicity issues in a sub-group of lymphoedema patients who may have had a reduced ability to metabolize this particular drug. In the future, pharmacogenomics may be used to overcome this problem by targeting the use of Coumarin to those with functional liver CYP2A6 (Farinola & Piller 2005).

Benzopyrone preparations may help limb oedemas by; decreasing the amount of extracellular fluid by reducing vascular permeability (Ramalet 2000; Roztocil 1993), increasing transcutaneous pO₂ (Wadworth & Faulds 1992), inhibiting leukocyte activation, adhesion and migration (Nicolaidis 2000), stimulating lymph contractility and flow (Clements 2000; Ramlett 2000), reducing protein concentration in the tissues (Knight et al 1989) and reducing the formation of fibrotic tissue by stimulating protein proteolysis by macrophages (Badger et al 2004; Rockson 2001; Piller 1976).

Types of Outcome Measures

The following measurement outcomes were considered to be appropriate for evaluating the impact of the conservative therapies:

- Changes in limb volume measured by;
 - water displacement
 - electronic volumeter/perometer or
 - calculated from tape measurements
- Changes in subjective limb symptoms.
- Changes in skin condition.
- Changes in quality of life, well being and/or activities of daily living.
- Recorded adverse effects related to the therapy/therapies under investigation.

Search Strategy

The Cochrane library database was first searched to establish whether a systematic review on this particular topic had not previously been undertaken. One systematic review by Badger et al (2005) was identified. However, the Badger et al (2005) review focused only on randomised controlled trials, parallel and cross-over trials, involved both primary and secondary lymphoedemas, did not include leg oedema of vascular origin and did not review oral pharmaceuticals or pneumatic pump therapy. Therefore this systematic review is not considered to be a replication.

The following online engines were searched; Cumulative Index to Nursing & Allied Health Literature (Cinahl), Medline, Academic Research Periodicals, PubMed Clinical Queries (including Complimentary Medicine), CANCERLIT, EBM Reviews - Cochrane Central Register of Controlled Trials, Cochrane Database of Systematic Reviews (CDSR), American College of Physicians (ACP) Journal Club, Database of Abstracts of Reviews of Effects (DARE), PREMEDLINE, Australian Medical Index, Physiotherapy Evidence Database (PEDro) and the National Guidelines Clearing House.

The general terms used for all these search engines were as follows:

- * Secondary lymphoedema/lymphedema
- * Chronic venous/vascular insufficiency
- * Arm swelling/oedema/edema
- * Leg swelling/oedema/edema

These were then combined with the following terms:

- * Complex/complete, physical/decongestive therapy
- * Manual lymphatic drainage/lymphatic massage/lymphatic drainage
- * Support stockings/hosiery
- * Compression garment/sleeve
- * Compression bandaging/bandage
- * Pneumatic/compression/intermittent pump therapy
- * Exercise/physical therapy
- * Elevation
- * Laser/Low level Laser/Laser therapy

In addition, health institution websites and online venous and lymphatic societies were also searched, including; Australian Institute of Health and Welfare, Agency for Healthcare Research and Quality, National Breast Cancer Centre, British Lymphology Society (online conference proceedings and newsletters titles), National Lymphedema Network (online featured articles), The Australian College of Phlebology (online abstracts), The American College of Phlebology (online abstracts from annual congresses 1997 – 2003), Japanese Society of Phlebology (online journal article titles), Lympha-venous Canada (online research articles) and The Vascular Society of Great Britain and Ireland (online publication titles).

The biennial congress proceedings of The International Society of Lymphology (1977 – 2003) and the Australian Lymphoedema Association (2000 – 2004) were searched by hand. Where publications were difficult to access through library sources, the primary author was contacted via e-mail or postal mail and asked to send the article in question. The reference section of each article was also checked for additional articles relating to the systematic review.

The title and abstract (if available) of each article found through the searches was reviewed using the selection criteria. If the article was immediately found not to be relevant to the review it was excluded. These articles plus the reason for their exclusion are recorded in appendix 3.1. If the relevance of the article could not be determined, then the whole article was sourced and reviewed.

Endnote 7[®] was used as the data extraction tool, with the following information from each included article being recorded:

- Article title and author(s)
- Journal (or proceedings) title, publication date, volume, issue and page numbers
- Sample size, sample demographics and withdrawal/drop out rate (explanation of)
- Study inclusion/exclusion criteria
- Cancer status (whether in remission) and swelling type (whether secondary arm or leg lymphoedema or vascular leg oedema)
- Treatment allocation, randomisation and blinding techniques
- Treatment method(s), duration and type of control
- Types of measurements taken and measurement interval (including follow up measurements)
- Type of statistical analysis performed
- Trial results and statistics.
- Conclusions & recommendations

Quality Assessment

Once the data had been extracted and recorded in Endnote 7[®], the quality of the study was assessed and given a rating. The Quality Scale Assessment tools used in this review were based upon a tool developed by Mulrow & Oxman (1996), with one tool being developed and used for the review of randomized trials and the other for non-randomized trials (appendices 3.2a and 3.2b). Each study was rated and recorded in a spreadsheet (appendix 3.3a and 3.3b).

Analysis

As this review considered a number of different treatment regimes, included different sample groups (ie: arm and leg lymphoedema, venous oedema) and had research findings that were reported differently (ie: volume or percentage or actual oedema reduction), data could not be combined to perform a meta-analysis of the conservative therapies. Although the majority of studies that involved oral pharmaceuticals were randomized, blinded (partial or double), placebo controlled trials, the sample groups represented within these trials were not homogenous and therefore the data could not be combined to perform a meta-analysis. Therefore this systematic review provides only a narrative of the different conservative therapy regimes.

Results

One hundred and forty articles were found and sixty one of these were reviewed. The data recorded in each reviewed journal article is presented without modification in table format in the following section. In particular, limb volume reduction was often recorded and presented in different ways (depending upon whether the 'normal' or 'control' limb is taken in to consideration) with examples including; actual volume reduction of the affected limb (mls), mean volume reduction (%), excess limb volume reduction (%) and actual oedema reduction (%). For ease of comparison, an approximate oedema reduction (%) has been calculated in each case where the limb volume reduction is presented in milliliters (mls). Where data is presented to two decimal places, it has been rounded to one decimal place, for example; 3.19 would be presented as 3.2.

Legend (for the results tables)

Abbreviation	Meaning
CO	Denotes the control group
Tx	Denotes the treatment group
Grp A, B, etc.	Denotes different treatment groups
↓	A reduction (improvement) occurred in the parameter
↑	An increase (worsening) occurred in the parameter
-	No change occurred in the parameter
n.s.	The results were not statistically significant
n =	Study sample size
~	Approximate
vol.	Limb volume
L/O	Lymphoedema
Tx	Treatment
mins	Minutes
hrs	Hours
wk	Week
nth	Month
f/up	Follow up
b/w	Between

Results

Complete Decongestive/Physio Therapy (CPT)

The retrospective study by Hinrichs et al (2004) relied upon medical records for data and had a small sample size of 14. Diagnosis of 'ipsilateral leg lymphoedema' by a Surgical Oncologist was the only stated selection criterion. The CPT treatment was stated as being applied over a 1-4 week period, with the average treatment time not being stated and therefore it is unknown. This trial reported a reduction in percentage oedema of 60%, but as there were no stated follow up measurements it is unknown as to whether there were any ongoing treatment effects. Although this trial reports the greatest percentage reduction in oedema in comparison to the other reviewed studies, it's small sample size and reliance upon medical records for data makes the results of limited value.

The study by Szolnoky et al (2002) was a randomized trial where women with arm lymphoedema were allocated to standard CPT (n=13) or CPT with the addition of 30 minutes of intermittent pump (50mmHg) therapy (n=14). Both treatment groups experienced a significant reduction in arm lymphoedema, with the CPT only group having a 3.1% reduction in mean volume and the CPT + pneumatic group having a statistically significant greater reduction of 7.9%. Although a reduction in symptoms was reported, it was not stated what symptoms were actually measured. The follow up measurements over one and two months demonstrated a continuing decrease in percentage volume in both treatment groups. Overall, the reductions achieved by these two treatment regimes were small in comparison to other CPT studies, with the small sample sizes also making it somewhat difficult to generalize these results.

Women with secondary arm lymphoedema were involved in Wozniowski et al's (2001) study which had a clearly stated inclusion and exclusion criteria and a large sample size of 188. The CPT regime instigated included manual lymphatic drainage followed by intermittent pump (40–70mmHg) application over 1 hour. However, the exact treatment time for the MLD and pump component is not stated. After 5 weeks of treatment the combined regime resulted in statistically significant percentage reductions in all grades of lymphoedemas (grade I – III, 43.4% - 19.3%). Subjective symptoms were not recorded so the impact upon these is unknown. There was also no follow up measurement in this trial, so again it is not known whether the percentage reductions were sustained.

The study by Szuba et al (2000) was not a formal clinical trial but a report of data collected from women with secondary arm lymphoedema who presented at a clinic for standard complex physical therapy followed by the fitting of a compression (30-40mmHg) sleeve. There was a reasonable sample size (n=43) included in this report but the exclusion criteria for treatment is not stated. The CPT treatment time varied from 5 – 15 days, with the average being 8 days. At the end of the treatment period there was a significant limb volume reduction of 298mls (44% excess oedema). Whether the best volume reduction was achieved over the shorter (5 day) or longer (15 day) treatment period is not explored. A greater limb volume reduction of 339mls (38%) was recorded at follow up (average 38 days) but this period was extremely variable, ranging from 5-273 days. This makes it hard to assess whether the stated follow up reduction is a true reflection of what was occurring in the sample group as a whole.

Piller et al's (1996) study involving women with arm lymphoedema had a clearly stated inclusion/exclusion criterion, but no stated sample size. A criticism of this study is that the lymphatic massage and compression bandaging was applied by the participant's partner and not a health care professional trained in the technique. However, this was the stated aim of the study and a reasonable reduction in percentage oedema (18.7%) and subjective symptoms was achieved. In fact, this was one of only a few CPT studies which recorded the change in subjective symptoms. Follow up measurements taken at the end of 1 and 6 months showed that the reduction in lymphoedema volume was maintained but no statistical values were reported for any time period, so statistical significance is not known.

Boris et al's (1994) study involving women with secondary arm lymphoedema had a small sample size (n=16), with no control group and no stated exclusion criteria. This group received standard CPT for four hours a day over a 1 month period. At the end of one month the group experienced a significant volume reduction of 444mls (~ 45%). Subjective symptoms were not recorded and there was no follow up period for this trial.

Twenty five women with secondary arm lymphoedema were involved in a study by Bunce et al (1994), which had a clearly stated inclusion and exclusion criteria. The therapy instigated was standard CPT with the inclusion of pneumatic pump (< 60mmHg) application of no more than 90 minutes a day, but the exact pump pressure applied and treatment time were not stated. After a month of this therapy there was a reduction of 40% in excess limb volume, however, the statistical significance of this reduction was not stated. This study included a follow up period over 12 months that found that the excess volume reduction was maintained but that the wearing of the compression sleeve and the use of limb exercises had declined. How the compliance to sleeve wearing and limb exercise was recorded is not stated. Although this

regime resulted in a reasonable limb volume reduction which was maintained over a 12 month period, the fact that the pump pressure applied, treatment time and compliance recording are unknown makes it difficult to replicate this regime in the clinical setting.

Carroll & Rose's (1992) study with a sample of 22 women with secondary arm lymphoedema had a poor quality rating (3/8) and a poor exclusion criterion, with 'pain related to other causes' as the only stated exclusion. This group received standard CPT but the length of massage given to the participants was not specified. Interestingly, this study was the only one that treated participants over a 3 month period (the majority of treatments in other CPT studies were applied over a 1 month period). After this time period there was a significant reduction in both limb volume (344mls ~ 35%) and reported pain. No follow up measurements were taken, so again it is not known whether these reductions were sustained.

The study by Casley-Smith & Casley-Smith (1992), like the Szuba et al (2000) study was not a formal clinical trial, but a report of measurements taken on 78 women with arm lymphoedema who had been treated with 1 month of CPT in a clinical setting. The only stated exclusion criteria was malignancy. This study reports the greatest reduction in volume (652mls ~ 66% in grade II lymphoedemas) in comparison to the other CPT studies. It also included a 12 month follow up measurement which found an additional (non significant) reduction of 80mls (~7.5%) in the grade I lymphoedemas and 32mls (~3.2%) in the grade II lymphoedemas. However, some of the initial participants had dropped out by the 12 month follow up. The type of maintenance therapy the participants undertook in the 12 month time period was not stated but it would appear that both groups (grade I & II lymphoedema) maintained the initial volume reduction.

A study by Swedborg (1984) involved 32 participants, had a good explanation of the inclusion/exclusion criteria and the drop out rate. The study investigated a combination of treatments on secondary arm lymphoedema, with each regime being applied over a 1 month period. Interestingly, one of the regimes included hot compresses in combination with MLD, exercise and a compression sleeve which resulted in a reduction of 12% in actual oedema. This is despite the potential increase in interstitial fluid that could occur as a result of the heat application and subsequent vasodilation. In the same trial, a regime of MLD, exercise and a compression sleeve worn day and night yielded similar percentage reductions (3 – 4% in arm volume, 11-13% in actual oedema). There was no follow up period in this trial, so it is not known whether any of the percentage reductions were maintained.

Overall it is hard to make comparisons of the benefits of CPT, as different outcomes are reported, including volume reduction (mls), percentage reduction in oedema and mean volume reduction expressed as a percentage. Also, none of the studies reviewed included a control group, so it is hard to determine how beneficial this form of treatment is in comparison to doing nothing at all. However, the reviewed studies did demonstrate a reduction in limb volume and/or percentage oedema which was maintained (when measured) at the follow up periods.

The optimal treatment period for CPT seems to be 1 month, however Swedborg (1980) found that the best results were achieved after 1 week of treatment and Szuba et al's (2000) study achieved a volume reduction of 298mls (~30%) after an average treatment period of 8 days. The study by Piller et al (1996) demonstrated that similar results could be achieved when patients and their partners were taught how to apply a regime of lymphatic massage and compression bandaging themselves.

Only three out of the ten studies reviewed measured subjective symptoms (Szolnoky et al 2002; Piller et al 1995; Carroll & Rose 1992). In all three studies the recorded subjective symptoms improved after CPT, unfortunately none of these studies report whether these improvements in subjective symptoms were sustained at the follow up periods. Five out of the ten studies reviewed did not have follow up measurements and therefore in these study populations it is unknown whether the initial reductions achieved from treatment were maintained.

The other five studies had a variety of follow up periods ranging from 1–12 months. All follow up periods demonstrated that the initial volume reduction was either maintained or that there had been further reductions. The preservation of this reduction is most likely related to the maintenance component of CPT which involves skincare, the wearing of a compression garment and limb exercises.

Table 3.1. Summary of Results of Complete Decongestive/Physio Therapy

Treatment Protocol	Change	Subjective Symptoms	Follow up	Quality Score	Reference
MLD, skincare, bandaging + exercises 60 mins daily over 1-4wks (n = 14)	↓ 60% in edema p = 0.0003	Not reported	Nil	4	Hinrichs et al (2004)
<u>Grp A:</u> 60mins of MLD, skincare, bandaging, exercise for 10 days (n = 13) <u>Grp B:</u> 30mins of MLD, 30 mins intermittent pump therapy (50mmHg), skincare, bandaging & exercise for 10 days (n = 14)	At end 10 days <u>Grp A:</u> ↓ 3.1% in mean vol p < 0.05 <u>Grp B:</u> ↓ 7.9% in mean vol p < 0.05 Grp B > A p < 0.05	Both grps experienced ↓ symptoms p < 0.05	<u>End 1mth</u> <u>Grp A:</u> ↓ 2.9% in mean vol p < 0.05 <u>Grp B:</u> ↓ 9.0% in mean vol p < 0.05 <u>End 2mths</u> <u>Grp A:</u> ↓ 3.6% in mean vol p < 0.05 <u>Grp B:</u> ↓ 9.6% in mean vol p < 0.05	4	Szolnoky et al (2002)
MLD then intermittent pump therapy (40–70mmHg) for 1 hr. Patients instructed to do 15 minutes per day + exercises. Tx 5 x week for 5wks (n = 188)	After Tx: Mild LO: ↓ 43.4% p < 0.001 Mod LO: ↓ 33.2% p < 0.001 Sev LO: ↓ 19.3% p < 0.001	Not reported	Nil	5	Wozniowski et al (2001)

Table 3.1. Summary of Results of Complete Decongestive/Physio Therapy (Cont.)

Treatment Protocol	Change	Subjective Symptoms	Follow up	Quality Score	Reference
MLD 30-60mins, bandaging + exercises for 5 – 15 days (average 8 days). Then sleeve (30-40mmHg) fitted (n = 43)	After Tx: ↓ 298mls (± 259) in volume ↓ 44% (± 62) in excess vol. p < 0.0001	Not reported	Average f/up 38 days (5-273) ↓ 339 (± 300) in volume ↓ 38% (± 52) excess vol. p < 0.0001	4	Szuba et al (2000)
Partner taught MLD + compression bandaging performed over a 9 week period (n = k/n)	After trial: ↓ 18.7% in L/O volume p value not stated	↓ tightness ↓ cramps ↓ heaviness ↓ tension ↓ pins & needles	<u>1mth</u> ↓ 25.5% in L/O volume <u>6mths</u> ↓ 19.7% in L/O volume p values not stated	5	Piller et al (1996)
MLD, bandaging, skin care + exercise 4hrs a day over 1 month (n = 16)	After 1 month: ↓ 444mls p < 0.001 ~ 44.4%	Not reported	Nil	4	Boris et al (1994)
MLD, pneumatic pump (< 60mg < 90mins), bandaging + exercise 3hrs a day, 5 days/wk over 1 month (n = 25)	After 1 month: ↓ 40% in excess volume p value not stated	Not reported	1, 6, 12 mth follow up: Limb volume stable	4	Bunce et al (1994)

Table 3.1. Summary of Results of Complete Decongestive/Physio Therapy (Cont.)

Treatment Protocol	Change	Subjective Symptoms	Follow up	Quality Score	Reference
MLD, exercise, skin care + sleeve. Treatment period not specified (n = 22)	After 3 months: ↓ 394mls p = 0.0012 ~ 39.2%	↓ pain p < 0.001	Nil	3	Caroll & Rose (1992)
MLD, bandaging, skin care + exercise 5-6 days a week over 1 month (n = 78)	After 1 month: Grade 1 L/O ↓ 322mls (± 60.0) p < 0.001 ~ 32.0% Grade 2 L/O ↓ 652mls (± 51.5) p < 0.001 ~ 65.0%	Not reported	<u>1 year</u> Grade 1 L/O ↓ 80mls (± 113) p = n.s. ~ 8.0% Grade 2 L/O ↓ 32mls (± 49) p = n.s. ~ 3.3%	3	Casley-Smith & Casley-Smith (1992)
Each pt got following tx in randomized fashion Tx Mon – Fri, over 4wks, with 4wk breaks in between treatments <u>Tx A</u> : manual + mechanical massage, hand grip exercise - 35mins, 40mmHg sleeve worn during the day. <u>Tx B</u> : hot compress 20mins, manual + mechanical mass, hand grip exercise - 35mins, 40mmHg sleeve worn daily.	Best effect after 1 wk: <u>Tx B & C</u> had similar results: ↓ 3 – 4% in arm volume ↓ 11-13% in actual oedema.	Not reported	Nil	4	Swedborg (1980)

Table 3.1. Summary of Results of Complete Decongestive/Physio Therapy (Cont.)

Treatment Protocol	Change	Subjective Symptoms	Follow up	Quality Score	Reference
<p><u>Tx C</u>: manual + mechanical mass, hand grip exercise - 35 mins, 40mmHg sleeve worn during the day & night. (n = 32)</p>	<p><u>Tx A</u> ↓ 2.4% in arm volume ↓ 8.5% in actual oedema p values not reported</p>	<p>Not reported</p>	<p>Nil</p>	<p>4</p>	<p>Swedborg (1980)</p>

Manual Lymphatic Drainage (MLD)

The study by McNeely et al (2004) involved women with secondary arm lymphoedema who received massage with compression bandaging (n=24) or compression bandaging alone (n=21), 5 days a week for 1 month. This study had a clearly stated inclusion and exclusion criteria and was randomized, with the investigator taking the measurements being blinded to the treatment allocation. Both treatment groups experienced similar reductions in arm volume (260mls and 246mls respectively) and percentage reduction (46.1% and 38.6% respectively), which were statistically significant within the groups but not between treatment groups. Subjective symptoms were not recorded and there were no follow up measurements taken.

The study by Dubois (2004) was of poor quality (rating=2/8) and had no clearly defined inclusion/exclusion criteria except for a brief statement of the sample group being 'those suffering from post mastectomy lymphoedema'. This study involved women who received 1 hour of MLD over 43 sessions (n=27) or 0.5 hour of pump therapy (40mmHg) followed by 0.5 hour of MLD over 25 sessions (n=62). Whether there was a criteria for allocating the women to the different treatment groups and how this was achieved (ie: whether it was randomised) is not stated. Results showed that the MLD alone and when combined with pneumatic pump therapy yielded similar reductions in oedema volume (40% and 45% respectively). These reductions are not accompanied by statistical values so it is not known whether they were significant. It is also difficult to compare the outcomes of these treatments, as the MLD group had a smaller sample size and longer treatment period (~ 2 months) compared to the pneumatic pump plus MLD group which had a larger sample size and a shorter treatment duration (~ 5 weeks).

The follow up period in this study, which ranged from 14–24 months, showed that if no further treatment was undertaken during this time period an increase in oedema volume of 33% occurred (when compared to the end of trial figure). In comparison, those who underwent regular treatment during this time experienced a slight reduction (1%) in oedema volume. Unfortunately, the type of treatment regime undertaken during the follow up period was not stated, so it is not known from this study what prevented the limb from increasing in oedema volume.

The results of Korpon et al's (2003) study were reported through conference proceedings, so even though it was a randomized trial involving a reasonable number of women with secondary arm lymphoedema (n=51), the inclusion/exclusion criteria, length and frequency of MLD and the measurement schedule are unknown (this is also reflected in the poor quality rating of 2/10). This study involved three groups, the first group received MLD only, the second received MLD + compression and the third received compression only (see also table 3.3). Both treatment regimes obtained statistically significant reductions, with the MLD alone group experiencing a volume reduction of 104mls (8%) and the MLD + compression group having a 156mls (23%) volume reduction. Both groups also had a reduction in reported heaviness, but only the MLD + compression group had a reduction in pain. This, combined with the greater reduction in arm volume (8% versus 23%) suggests that the combination of MLD + compression is superior to MLD alone.

The study by Williams et al (2002) had a good inclusion and exclusion criteria and involved a randomized, cross over design involving women with secondary arm lymphoedema. The first group (n=13) received 45 minutes of MLD for 3 weeks then after a 6 week break, applied 20 minutes of self massage for 3 weeks. The second group (n=14) started with applying the self

massage and then crossed over to the MLD phase. The MLD phase of this trial resulted in a statistically significant reduction of 70mls (~ 7%) in comparison to a non significant reduction of 30mls (~3%) in the self massage phase. Only the MLD phase resulted in significant reductions in reported pain, heaviness, fullness and bursting. There was no follow up period in this study so it is not known whether these reductions were sustained.

Anderson et al's (2000) randomized study involving women with secondary arm lymphoedema had a good inclusion/exclusion criterion and included a control group. However, one criticism would be that the 'control' group (n=22) actually undertook activities that could benefit the swollen limb, including education, wearing a compression sleeve and limb exercises. In fact, the results demonstrate that these activities instigated over a 2 week period actually resulted in a greater percentage reduction in absolute oedema (60%) in comparison to the group (n=20) who received 40 minutes of additional MLD over the same time period (48%). Both groups equally experienced a reduction in the symptoms of heaviness and tightness, whilst the 'control' group also had a reduction in reported discomfort. This study also included a 12 month follow up measurement, with pooled data demonstrating that the reduction in absolute oedema (66%) was maintained at this time point.

A study by Johansson et al (1999) involving women with secondary arm lymphoedema included randomization and a good explanation of the inclusion/exclusion criteria and drop out rate. This study investigated the effects of compression bandaging applied over 3 weeks (n=17) and when combined with 45 minutes of MLD in the last week of treatment (n=18). The MLD plus bandaging group experienced a volume reduction of 47mls (11% in oedema) which was greater than that of the bandaging alone group (20mls, 4%). The percentage reduction of the MLD plus bandaging group (11%) was statistically significant in comparison to the bandaging

alone group (4%). Both groups experienced significant reductions in reported tension and heaviness, whilst the MLD plus bandaging group also had a significant reduction in pain. The greater reductions in limb volume and percentage oedema in combination with the additional reduction in reported pain would indicate the MLD plus bandaging is superior to bandaging alone.

Women with secondary arm lymphoedema were also involved in Johansson et al's (1998) study which again included randomization and a good explanation of the exclusion criteria and drop out rate. This study included a group that received pneumatic pump therapy (see also table 3.6) and a group that received 45 minutes of MLD (n=12). Participants in this group first wore a compression (30-40mmHg) sleeve for 2 weeks before undergoing 2 weeks of MLD plus wearing of the compression sleeve. Wearing the sleeve alone resulted in a significant volume reduction of 49mls (7%), with the addition of MLD resulting in a significant reduction of 75mls (15%). Both phases also resulted in significant tension and heaviness reductions. The overall design of this trial makes it difficult to determine the effect of MLD as a separate therapy, as the wearing of the compression sleeve had an effect on both arm volume and subjective symptoms before the MLD was introduced.

A study by Piller et al (1994) had a good inclusion/exclusion criteria but only a small sample size of women with secondary arm lymphoedema (n=12). After 10 sessions of 45 minutes of MLD there was a limb volume reduction of 155.8mls (10.2%), but no statistical values were stated. This study was the only one that did not report subjective symptoms but did include a 6 month follow up, which showed the volume reduction from the initial treatment was sustained. This may be related to the participants being educated on self massage, skincare, exercises and the wearing of a compression sleeve at the end of the initial trial period.

The majority of reductions in the reviewed MLD studies were seen after 2 weeks of MLD treatment. Two studies (Korpon et al 2003; Piller et al 1994) showed the greatest reduction in arm volume of 156mls (23%), with this reduction being obtained by Korpon et al (2003) in combination with compression. The greatest percentage oedema reduction of 43% was achieved by Anderson et al (2000), whilst a number of studies (Williams et al 2002; Johansson et al 1998; Johansson et al 1999) achieved smaller volume reductions which ranged from 47-75mls (11-15%).

Three studies (McNeeley et al 2004; Korpon et al 2003; Johansson et al 1999) investigated manual lymphatic drainage plus compression in comparison to compression alone. Two of these studies (Korpon et al 2003; Johansson et al 1999) demonstrated that MLD combined with compression was superior to bandaging alone in terms of limb volume and pain reduction. In contrast to this, the study by McNeely et al (2004) demonstrated similar reductions with both MLD combined with bandaging and bandaging alone.

The studies by Andersen et al (2000) and Piller et al (1994) had follow up periods that demonstrated that the limb reductions achieved by the initial trial had been maintained. However, the overall reduction at follow up is not stated in Piller et al's (1994) study. The follow up period in DuBois' (2004) study showed that a form of maintenance therapy needed to be regularly undertaken to maintain the reduction obtained from the initial treatment. The fact that the majority of the studies reviewed did not have follow up measurements makes it difficult to determine whether MLD (plus or minus compression bandaging) has any sustained benefits in terms of volume reduction and subjective symptom control.

Table 3.2. Summary of Results of Manual Lymphatic Drainage (MLD) Trials

Treatment Protocol	Change	Subjective Symptoms	Follow up	Quality Score	Reference
<p><u>Grp A:</u> 45 mins MLD + compression bandaging, 5 days/wk for 4 weeks (n = 24)</p> <p><u>Grp B:</u> compression bandaging only, 5 days/wk for 4 weeks (n = 21)</p>	<p><u>Grp A:</u> ↓ 260mls (± 217) ↓ 46.1% (± 22.6) p < 0.001</p> <p><u>Grp B:</u> ↓ 246mls (± 159) ↓ 38.6% (± 16.1) p < 0.001</p> <p><u>B/W grps:</u> ↓ mls p = 0.812 ↓ % p = 0.297</p>	<p>Not reported</p>	<p>Nil</p>	<p>8</p>	<p>McNeeley et al (2004)</p>
<p><u>Grp A:</u> 1hr MLD for 43 Sessions (n = 27)</p> <p><u>Grp B:</u> 0.5hr pump therapy @ 40mmHg followed by 0.5hr MLD for 25 sessions (n = 62)</p>	<p>After regime:</p> <p><u>Grp A:</u> ↓ 40% in oedema vol</p> <p><u>Grp B:</u> ↓ 45% in oedema vol p values not reported</p>	<p>Not reported</p>	<p><u>Grp A:</u> ‘somewhat satisfactory’</p> <p><u>Grp B:</u> ↑ 33% in oedema vol in those who had no f/up treatment ↓ 1% in those who had f/up treatment</p>	<p>2</p>	<p>DuBois (2004)</p>

Table 3.2. Summary of Results of Manual Lymphatic Drainage (MLD) Trials (Cont.)

Treatment Protocol	Change	Subjective Symptoms	Follow up	Quality Score	Reference
<p><u>Grp A</u>: MLD only (n = 17)</p> <p><u>Grp C</u>: MLD + Compression (n = 17)</p> <p>Treatment time period not reported</p>	<p><u>Grp A</u>: ↓ 104mls, 8% p < 0.01</p> <p><u>Grp C</u>: ↓ 156mls, 23% p < 0.01</p>	<p>All grps:</p> <p>↓ heaviness p = 0.03</p> <p>↓ tension p = 0.01</p> <p>Grp C only:</p> <p>↓ pain p = 0.00</p>	Nil	2	Korpon et al (2003)
<p><u>Grp A</u>: 3wks of daily 45min MLD, 6wks break, 3wks daily 20min self massage (n = 13)</p> <p><u>Grp B</u>: 3wks of daily 20min self massage, 6wks break, 3wks of daily 45min MLD (n = 14)</p>	<p>After regime:</p> <p><u>MLD</u></p> <p>↓ 71mls (CI 16 - 126) p = 0.013</p> <p>~ 7.2%</p> <p><u>Self Mass</u></p> <p>↓ 30mls (CI -4 - 63) p = 0.08</p> <p>~ 3.0%</p>	<p><u>MLD</u></p> <p>↓ pain p = 0.01</p> <p>↓ heaviness p = 0.003</p> <p>↓ fullness p < 0.001</p> <p>↓ bursting p = 0.008</p>	Nil	5	Williams et al (2002)
<p><u>CO</u>: sleeve, exercise, education (n = 22)</p> <p><u>Tx</u>: as above + 40mins of MLD, 4 x week over 2 weeks (n = 20)</p>	<p>After 3 mths:</p> <p><u>CO</u></p> <p>↓ 60% in absolute oedema</p> <p><u>Tx</u></p> <p>↓ 48% in absolute oedema</p> <p>p values not reported</p>	<p><u>CO</u></p> <p>> ↓ in discomfort, heaviness & aching</p> <p><u>Tx</u></p> <p>> ↓ in heaviness & tightness</p> <p>p vakues not reported</p>	<p><u>After 12 months:</u></p> <p>↓ 66% in oedema vol. (pooled data) p < 0.001</p>	5	Andersen et al (2000)

Table 3.2. Summary of Results of Manual Lymphatic Drainage (MLD) Trials (Cont.)

Treatment Protocol	Change	Subjective Symptoms	Follow up	Quality Score	Reference
<p><u>CO</u>: bandaging for 3 wks (n = 17)</p> <p><u>Tx</u>: as above, + 45mins of MLD for 5 days in the last week (n = 18)</p>	<p>In last week:</p> <p><u>CO</u></p> <p>↓ 20mls (\pm 46mls)</p> <p>4% (\pm 10%) oedema p = n.s.</p> <p><u>Tx</u></p> <p>↓ 47mls (\pm 42mls)</p> <p>11% (\pm 9%) oedema p < 0.001</p> <p><u>B/W grps</u></p> <p>↓ mls p = n.s</p> <p>↓ % p = 0.04</p>	<p><u>Co</u></p> <p>↓ tension p < 0.001</p> <p>↓ heaviness p < 0.006</p> <p><u>Tx</u></p> <p>↓ tension p < 0.001</p> <p>↓ heaviness p < 0.001</p> <p>↓ pain p < 0.03</p>	<p>Nil</p>	<p>6</p>	<p>Johansson et al (1999)</p>
<p>2 weeks of wearing a compression sleeve (30-40mmHg) followed by 45mins of MLD + sleeve, 10 sessions over 2 weeks (n = 12)</p>	<p>After regime:</p> <p><u>sleeve alone:</u></p> <p>↓ 49mls p = 0.01</p> <p>↓ 7% p = 0.05</p> <p><u>MLD + sleeve:</u></p> <p>↓ 75mls, 15% in oedema p < 0.001</p>	<p><u>After sleeve alone:</u></p> <p>↓ tension p = 0.004</p> <p>↓ heaviness p = 0.01</p> <p><u>MLD + sleeve:</u></p> <p>↓ tension p = 0.01</p> <p>↓ heaviness p = 0.008</p>	<p>Nil</p>	<p>5</p>	<p>Johansson et al (1998)</p>

Table 3.2. Summary of Results of Manual Lymphatic Drainage (MLD) Trials (Cont.)

Treatment Protocol	Change	Subjective Symptoms	Follow up	Quality Score	Reference
45 mins of MLD, 10 sessions over 2weeks (n = 12)	After regime: ↓ 156mls, 10.2% (\pm 15.9%)	Not reported	Consistent arm volume reduction after 6 months	5	Piller et al (1994)

Compression (Garments or Bandaging) for Limb Lymphoedema

Korpon et al's (2003) study involved 55 women with arm lymphoedema who were randomized into MLD alone (see also table 3.2), compression alone or MLD plus compression. How the randomization was performed was not described, nor was the inclusion/exclusion criteria, the length of treatment or measurement interval. Results showed that the compression alone resulted in a significant arm volume reduction of 38mls (7%), whilst MLD plus bandaging resulted in a greater volume reduction of 156mls (23%). Both forms of treatment resulted in significant reductions in heaviness and tension with the addition of MLD resulting in a reduction in pain, psychological distress and physical dysfunction. This study shows that a slight reduction in arm volume and reported heaviness and tension can be achieved with the application of compression bandaging, but that the addition of MLD seems to be superior in terms of both volume reduction and additional improvements in subjective symptoms.

Twenty women with arm lymphoedema were involved in Ang et al's (2002) pilot study which had a clearly stated inclusion and exclusion criteria. The women in this trial received treatment for 12 weeks and were divided into the treatment groups according to arm size; those with an arm circumference < 3cms received manual lymphatic drainage plus wore a compression garment, whilst those with a circumference > 3cms received manual lymphatic drainage plus compression bandaging. Why this particular criteria was used to allocate participants to the different treatment groups is not explored. Both treatment groups experienced significant reductions in oedema of 84% and 78% respectively. These results demonstrate that either type of compression (bandaging or garment) can be used successfully in combination with MLD. Subjective symptoms were not reported and no follow up measurements were performed in this study.

The study by Anderson et al (2000) included a sample of 42 women with secondary arm lymphoedema, a good inclusion/exclusion criteria and randomization. After 3 months, this particular study showed that there was a greater reduction in absolute oedema in the group (n=22) that wore a compression and undertook limb exercise in comparison to the group (n=20) who did this and had additional manual lymphatic drainage (60% versus 48%). Both groups experienced a reduction in tightness and heaviness, with the compression garment only group also having a reduction in aching. Statistical values for these reductions were not stated, so it is not known whether any of them were significant. At 12 months follow up the reduction in absolute oedema (66%) was maintained (pooled data). Why the data was pooled at the 12 month period and not analysed and represented separately is not explored.

Thirty five women with arm lymphoedema were involved in the Johanssen et al (1999) study which included a randomized allocation technique, a clear inclusion/exclusion criterion and a record of the study drop outs. In this trial, compression bandaging applied over a 3 week period resulted in a volume reduction of 20mls (4% oedema) whilst the addition of 45 minutes of MLD in the last week of treatment equated to a slightly greater volume reduction of 47mls (11% oedema). Both groups experienced a statistically significant reduction in tension and heaviness, with the addition of manual lymphatic drainage also resulting in a reduction in arm aching. The greater improvements in the MLD plus bandaging group would again suggest that this combination is superior to bandaging alone.

Another study undertaken by Johanssen et al (1998) investigated the benefits of wearing a compression (30-40mmHg) garment over a two week period in 12 women with secondary arm lymphoedema. This study also had a clear stated inclusion/exclusion criteria and explanation of the drop out rate. After 2 weeks of wearing the compression garment there was a significant

reduction in limb volume of 49mls (7%) and reported arm tension and heaviness. As this group entered a second treatment phase in the trial, there was no follow up measurement performed and therefore it is not known whether these reductions would have been maintained.

Hornsby's (1995) study included 25 women who presented at a breast clinic with arm swelling. The inclusion and exclusion criteria for this study was not stated nor were any descriptive statistics of the sample group included. It is stated that the women were randomized into either a control or treatment group but the randomization technique used is not described. The type and gradient of compression worn by the treatment group is also not stated. In this trial, the control group (n=11) undertook exercise, skincare and self massage for 4 weeks, whilst the treatment group (n=14) undertook these activities as well as wearing a compression garment. This resulted in a volume reduction of 243mls (~ 25%) after 1 week of treatment in comparison to the control group who had a reduction of 12mls (~ 1.2%). However, no statistical values are stated for these reductions and there is no follow up period, so it is not known whether they were significant or whether the reductions were maintained. The overall poor quality of this study (rating=1/10) makes the results somewhat unreliable and not knowing the type of compression used makes it difficult to translate the results into clinical practice.

The study by Swedborg (1984) involved 26 women with arm lymphoedema who underwent a control period, then 6 months of wearing a class II (30-40mmHg) compression garment. The study had a good inclusion/exclusion criteria but the control period ranged from 1.5–10.3 weeks (average 4 weeks), which could be considered a confounding variable. During this period measurements were taken on at least 2 occasions, but the exact measurement intervals are not stated. This study demonstrated that wearing a compression garment resulted in a significant 4% reduction in actual oedema after one week of wear, with an overall 8%

reduction in actual oedema after 6 months. However, by the 6 month time point only 12 women remained in the study. As the type of statistical analysis performed on the data is not stated, it is not known whether this attrition rate was taken into consideration and therefore whether the 8% reduction is an accurate representation of what can be achieved from wearing this type of compression garment.

Four of the reviewed studies (Korpon et al 2003; Johanssen et al 1999 & 1999; Swedborg 1984) demonstrated that modest volume reductions of 20–49mls (4-8%) and significant improvements in heaviness and tension could be achieved when wearing compression (bandaging or garment) alone. Anderson et al (2003) and Hornsby (1995) showed that greater volume reductions of 243mls (24.4%) and 60% could be achieved when the wearing of a compression garment was combined with limb exercise and self massage. The studies by Korpon et al (2003), Ang et al (2002), Anderson et al (2002) and Johanssen et al (1999) also demonstrated that greater volume reductions of 11-84% and improvements in pain could be achieved when compression was combined with manual lymphatic drainage.

Table 3.3a. Summary of Results of Compression (Garments or Bandaging) for Limb Lymphoedema

Treatment Protocol	Change	Subjective Symptoms	Follow up	Quality Score	Reference
<p><u>Grp B</u>: Compression bandaging only (n = 17)</p> <p><u>Grp C</u>: MLD + compression bandaging (n = 17)</p> <p>Treatment time period not reported</p>	<p><u>Grp B</u>: ↓ 38mls, 7% p < 0.01</p> <p><u>Grp C</u>: ↓ 156mls, 23% p < 0.01</p>	<p>All grps: ↓ heaviness p = 0.03 ↓ tension p = 0.01</p> <p><u>Grp C only</u>: ↓ pain p = 0.00 ↓ in reported psychological distress + physical dysfunction</p>	Nil	2	Korpon et al (2003)
<p><u>Grp A</u>: 45 mins MLD + compression</p> <p><u>Grp B</u>: 45 mins MLD + bandaging (n = 20)</p> <p>both grps: 1 x week for 12wks</p>	<p>After 12 wks:</p> <p><u>Grp A</u>: ↓ 84% in oedema p = 0.022</p> <p><u>Grp B</u>: ↓ 78% in oedema p = 0.001</p>	Not reported	Nil	6	Ang et al (2002)
<p><u>CO</u>: sleeve, exercise, education (n = 22)</p> <p><u>Tx</u>: as above + 40mins of MLD, 4 x week over 2 weeks (n = 20)</p>	<p>After 3 mths:</p> <p><u>CO</u> ↓ 60% in absolute oedema</p> <p><u>Tx</u> ↓ 48% in absolute oedema p values not reported</p>	<p><u>CO</u> > ↓ in discomfort, heaviness & aching</p> <p><u>Tx</u> > ↓ in heaviness & tightness p values not reported</p>	<p><u>After 12 months</u>: ↓ 66% in oedema vol. (pooled data) p < 0.001</p>	5	Andersen et al (2000)

Table 3.3a. Summary of Results of Compression (Garments or Bandaging) for Limb Lymphoedema (Cont.)

Treatment Protocol	Change	Subjective Symptoms	Follow up	Quality Score	Reference
<p><u>CO</u>: bandaging for 3 weeks (n = 17)</p> <p><u>TX</u>: as above, + 45mins of MLD for 5 days in the last week (n = 18)</p>	<p>In last week:</p> <p><u>CO</u> ↓ 20mls (± 46mls) 4% (± 10%) oedema p = n.s.</p> <p><u>TX</u> ↓ 47mls (± 42mls) 11% (± 9%) oedema p < 0.001</p> <p><u>B/W grps</u> ↓ mls p = n.s., ↓ % p = 0.04</p>	<p><u>Co</u> ↓ tension p < 0.001 ↓ heaviness p < 0.006</p> <p><u>TX</u> ↓ tension p < 0.001 ↓ heaviness p < 0.001 ↓ pain p < 0.03</p>	Nil	6	Johansson et al (1999)
2 weeks of wearing a compression sleeve (30-40mmHg) (n = 12)	<p>After 2 weeks: ↓ 49mls p = 0.01 ↓ 7% p = 0.05</p>	<p>↓ tension p = 0.004 ↓ heaviness p = 0.01</p>	Nil	5	Johansson et al (1998)
<p><u>CO</u>: skincare, exercise, self massage (n = 11)</p> <p><u>TX</u>: as above + compression sleeve (pressure gradient not specified) for 4wks (n = 14)</p>	<p>After 1 week: CO: ↓ 12mls ~ 1.2% TX: ↓ 243mls ~ 24.4% p values not reported</p>	Not reported	Nil	1	Hornsby (1995)

Table 3.3a. Summary of Results of Compression (Garments or Bandaging) for Limb Lymphoedema Cont.

Treatment Protocol	Change	Subjective Symptoms	Follow up	Quality Score	Reference
Control period of no treatment (average 4 wks) then wore 30-40mmHg compression sleeve for 6 months (n = 26)	<p>After 1 week: ↓ 4% actual oedema p = 0.001</p> <p>After 1 month: ↓ 5% actual oedema p = 0.001</p> <p>After 3 months: ↓ 6% actual oedema p = 0.002</p> <p>After 6 months: ↓ 8% actual oedema p = 0.025</p>	Not reported	Nil	5	Swedborg (1984)

Compression Garments for Leg Oedema

Diehm et al's (1996) study involved a large sample size of 99 participants with leg oedema subsequent to chronic venous insufficiency. It also included randomization, a clearly stated inclusion/exclusion criteria and partial blinding (although the blinding technique used was not explained). In this trial, participants first took an oral diuretic (25mg hydrochlorothiazide/50mg triamterence) for 1 week to reduce the leg volume before a class II compression garment was fitted and subsequently worn for 12 weeks. After this time there was a significant volume reduction of 43mls (~ 4.4%), which may be considered modest when the overall volume of an oedematous leg is considered. Subjective symptoms were not recorded during this trial and there were no follow up measurements performed.

Ukauf et al's (1996) study was a randomized, double blinded, parallel design with a clearly stated inclusion/exclusion criteria and a good explanation of the drop out rate, with an overall good quality rating (7/10). The study involved two treatment regimes, with the first treatment group receiving an oral diuretic (type not specified) for 1 week followed by wearing a mid-length class II compression garment and taking a placebo tablet for 12 weeks. The second group received the oral diuretic followed by Oxerutin (1,000mg) in substitution of the placebo tablet. The following discussion will focus only on the group (n=56) who wore the compression garments and received the placebo tablet.

The results from this group demonstrated that after 4 weeks of wearing a compression garment there was a volume reduction of 25mls (~ 2.5%) which increased to 33mls (~ 3.2%) at 12 weeks. At 12 weeks there were also reductions in subjective symptoms such as heaviness, tiredness, tension and tingling. Statistical values are not stated for the volume or subjective symptom reductions. At 1 month follow up there was an increase in limb volume of 9mls (~

0.8%) and a slight worsening of all the subjective symptoms in comparison to end of treatment, with the increases in limb volume, heaviness and tiredness being reversed at the 2 month follow up. Why there was an initial increase in these parameters at the 1 month follow up was not explored.

Participants with vascular oedema subsequent to chronic venous insufficiency were involved in Nuemann & van den Broek's (1995) study which had a detailed inclusion and exclusion criteria, but a small sample size of 12. There was also no statement of drop outs from the study and therefore no indication of how well the compression garments were tolerated by the study population. Results showed that there was a statistically significant limb volume reduction of 230mls (~ 22.8%) after wearing compression (grade II) garments for 4 months. Subjective symptoms were not reported for this study, so it is not known whether these would have been improved by the wearing of this particular compression garment. There was also no follow up period, so it is not known whether the reduction in limb volume was sustained beyond the four month period.

Seventy three participants who had swelling of vascular origin were involved in Pierson et al's (1983) study. The rationale for this study was clearly stated, as was the inclusion criteria but no exclusion criterion was included. Whether any participants withdrew from the study was also not stated. The study itself was relatively short in duration, with participants wearing either below the knee or panty hose support garments (24mmHg at the ankle) for 1 week. How many participants were allocated to the below the knee and panty hose groups was not recorded. At the end of the week there was a statistically significant reduction in volume of 100mls (~10%) and reported pain. It was also reported that there was no significant differences between the

results obtained from the below the knee stockings compared to the panty hose, indicating that either could be implemented in the clinical setting.

The four studies reviewed indicate that varying volume reductions can be achieved by wearing compression garments, ranging from 43mls ~ 4.4% (Diehm et al 1996) to 230mls ~ 22.8% (Neumann & van den Broek's 1995). Only one study (Ukauf et al 1996) included a follow up period of 2 months which demonstrated that the initial reductions had been maintained. As the majority of these studies did not state the drop out rate nor include a follow up period, it is difficult to ascertain the compliance rate of wearing compression garments in venous oedema populations.

Table 3.3b. Summary of Results of Compression Garments for Leg Oedema

Treatment Protocol	Change	Subjective Symptoms	Follow Up	Quality Score	Reference
7 days of diuretics (25mg hydrochlorothiazide/50mg triamterence) followed by compression class II for 12 weeks (n = 99)	After 12 wks: ↓ 43mls (± 11.4) p = 0.002 ~ 4.4%	Not reported	Nil	6	Diehm et al (1996)
1 week of diuretic (type not specified) then fitted with a mid-length class II (21.1 - 31.5mmHg) stocking and took placebo tablet for 12 weeks (n = 56)	After 4wks: ↓ 25mls (± 90.2) ~ 2.5% After 8wks: ↓ 29mls (± 92.3) ~ 2.9% After 12wks: ↓ 33mls (± 104.5) ~ 3.3% p values not stated	Overall: ↓ heavy/tired ↓ tension ↓ tingling	<u>1 month</u> ↑ 9mls (± 102.9) ↑ heavy/tired ↑ tension ↑ tingling <u>2 months</u> ↓ 8mls (± 103.8) ↓ heavy/tired ↑ tingling	5	Ukauf et al (1996)
Wore class II compression stocking for 4 mths (n = 12)	End of regime: ↓ 230.0mls (± 24.6) p < 0.001 ~ 22.8%	Not reported	Nil	4	Nuemann & van den Broek (1995)
Wore below the knee stockings or panty hose (24mmHg at ankle) for 1 week (n = 73)	After 1wk: ↓ 100mls p = 0.0001 ~ 10.0%	↓ pain p = 0.0001	Nil	5	Pierson et al (1983)

Exercise Regimes for Limb Lymphoedema

The study by Moseley et al (2005) investigated a combined arm exercise plus deep breathing regime for women with secondary arm lymphoedema (see chapter 4 for a detailed description of the exercise regime performed). This study had a clear explanation of the inclusion and exclusion criteria and of the exercise regime performed. The initial phase of the study involved thirty eight women undertaking the regime for 10 minutes, which resulted in a significant reduction in arm volume of 52mls (5.8%) and in reported heaviness and tightness. Some of the reduction in arm volume was also sustained over 24 hours (46mls, 4.3%) and at 1 week follow up (33mls, 3.5%). Reported arm heaviness also remained improved over these time periods. However, it is impossible to know with any certainty whether the participants performed the deep breathing and arm exercise during the 1 week follow up period (even though they were specifically instructed not too).

The second phase of the study involved a smaller cohort of 24 women who continued to undertake the 10 minute regime morning and evening over 1 month. This resulted in a greater reduction in limb volume of 101mls (9%) and improvements in heaviness and perceived limb size. These improvements were in comparison to a historical control group (n=28) who received no treatment over 1 month and had a 7ml (~ 0.7%) volume reduction and no significant improvements in subjective symptoms. One criticism of this study is that a historical control group (which was comparable) was used rather than participants being randomized into control and treatment groups at trial entry.

The study by Box et al (2004) involved 16 women with arm lymphoedema who were randomized to either a control group (n=8) or a hydrotherapy exercise group (n=8), with the hydrotherapy consisting of 15 minutes of slow rhythmical exercise followed by 20 minutes of vigorous whole body activities then 10 minutes of warm down exercise. This study included randomization but did not state an inclusion/exclusion criterion. It is also did not state what the control was, so it is difficult to make a comparison between this group and the exercise group.

The group that undertook hydrotherapy three times a week for four weeks had a non significant volume reduction of 48mls (~ 4.8mls); interestingly there were continual volume reductions at both 3 and 6 week follow up (30mls ~ 2.9% and 86mls ~ 8.6% respectively). This is in comparison to the control group, which increased in arm volume both initially (1.2mls, ~ 0.1%) and at the follow up time points (50mls ~ 5% and 32.5mls ~ 3.2% respectively). Both groups reported reductions in symptoms such as aching, heaviness and tightness. However, only the exercise group had significant reductions in reported limb swelling, stiffness and heat intolerance.

Buckley et al's (2004) pilot study involved 14 participants with either secondary arm (n=7) or leg lymphoedema (n=7) who performed one 30 minute regime of instructed (by a physiotherapist) deep breathing, self massage and sequential limb exercises (see chapter 4 for a detailed description of the regime performed). The study had a good rationale but no stated exclusion criteria, with the only inclusion criteria being stated as 'diagnosis of mild secondary limb lymphoedema'. In this study the arm lymphoedema group experienced a slight increase in volume (12mls ~ 0.4%) directly after undertaking the instructed program. At 20 minutes post regime this increase had been reversed, with a net reduction of 12mls (~ 0.4%). The leg lymphoedema group experienced a volume reduction immediately after the regime of 55mls

(~ 5.8%) and at the 20 minute mark of 31mls (~ 3.0%). Both groups experienced good improvements in subjective symptoms such as heaviness, tightness, limb temperature difference and improved limb range of movement.

Women with arm lymphoedema secondary to breast cancer treatment were involved in two studies undertaken by Johansson et al (2004). These studies had a clear explanation of the inclusion criteria and of the performed exercise regimes, but no stated exclusion criteria or whether there were drop outs or adverse effects from the studies. The first study involved 7 women and investigated two sessions of a 40 minute hydrotherapy pool regime, the first undertaken in a temperature of 28°C (82°F) and the second in 34°C (93°F). The hydrotherapy regime included 15 minutes of swimming followed by racing exercises, arm exercises with hand weights and a cooling down period. After the first session (28°C) there was a decrease in arm volume of 32mls (12% oedema change), whilst after the second session (34°C) there was a slight increase in volume of 2mls (7% change, which seems slightly high in comparison to the actual 2ml volume increase). Reported arm heaviness and tension remained unchanged after both sessions. This study indicates that for women with arm lymphoedema a pool temperature of 28°C (82°F) is better for undertaking exercise in.

The second study by Johansson et al (2004) involved twenty three women and investigated the effects of resistance arm exercise performed firstly with no compression garment and secondly when wearing a compression garment. The exercise regime involved shoulder flexion and abduction and elbow extension and flexion using 0.5kg hand weights. Results showed an initial increase in arm volume after performing the regime, regardless of whether compression was or was not worn (12mls, 0.5% and 10mls, 0.3% respectively). However, at the 24 hour follow up the volume increases had been reversed, with both phases (plus and minus sleeve)

demonstrating a volume reduction of 15mls (0.7 – 1.0%) at this time point. Reported tension and heaviness remained unchanged in both phases, however, when the regime was performed without a compression garment there was a significant increase in reported physical exertion which did not occur when a garment was worn.

Thirty three participants with secondary leg lymphoedema subsequent to cancer treatment were involved in a study by Moseley et al (2004) which had a clearly stated inclusion and exclusion criteria. This group used an aerobic exerciser that delivered slight elevation and passive leg exercise in the home over a 3 week period (see chapter 4 for a detailed description of the machine and treatment schedule). At the end of this time the group experienced statistically significant reductions in limb volume (330mls ~ 33%) and subjective symptoms such as heaviness, pain, tightness and in reported skin dryness and perceived limb size. At the 1 month follow up there had been an increase in limb volume of 100mls (~ 10%), however the limb volume at this time was still lower than the pre-treatment level. Subjective symptoms also increased but did not return to pre-treatment levels.

The study by McKenzie & Kalda (2003) had a good inclusion criterion and consisted of 7 women with secondary arm lymphoedema being randomized to wearing a compression garment only and 7 to a resistive exercise program undertaken three times a week for eight weeks plus the wearing of a compression garment. This program consisted of 10 minutes of warming up and stretching, followed by latissimus dorsi, bicep and tricep exercises using weights followed by a cool down period (time not specified). After 2 weeks, 5-20 minutes of upper body aerobic exercise using an arm cycle ergometer was added to this regime.

The exercise plus compression group experienced a small reduction in limb volume of 2% (approximately 20-25mls), whilst the group who wore only a compression garment experienced an increase of 3% (approximately 30mls). The exercise plus compression group also reported significant improvements in physical functioning, general health and vitality, whilst these same parameters worsened in the compression only group. This study did not include a follow up period so it is not known whether the benefits from undertaking the exercise regime and wearing a compression garment were sustained.

The five studies involving women with arm lymphoedema demonstrate that different exercise regimes can have a varying impact upon limb volume, ranging from 12 – 101mls (0.4 – 9%), whilst in those with leg lymphoedema a reduction of 330mls (~ 33%) was achieved. In the majority of cases, there were also improvements in subjective symptoms such as heaviness and tightness and in limb function. Sustained benefits also occurred after exercise program cessation, with Moseley et al (2005) showing a reduction in volume and subjective symptoms 24 hours and 1 week after the initial exercise regime, Johansson et al (2004) a reduction in volume after 24 hours and Box et al (2004) demonstrating continued reductions in arm volume at 3 and 6 weeks post exercise cessation.

The studies by Johansson et al (2004) and McKenzie & Kalda (2003) demonstrated that resistive exercise undertaken with hand weights did not exacerbate arm swelling and can, in fact, result in a slight reduction in limb volume (which occurred in Johansson et al's study 24 hours post regime). Johansson et al (2004) also showed that wearing a compression garment during weight training may not influence the initial increase in limb volume but may combat the physical fatigue experienced by the wearer whilst lifting weights.

Table 3.4a. Summary of Results of Exercise Regimes for Limb Lymphoedema

Treatment Protocol	Change	Subjective Symptoms	Follow Up	Quality Score	Reference
<p><u>Tx</u>: 10 mins arm exercise + deep breathing, some continued regime morning & evening for 1 mth. Initial: n = 38 1 month: n = 24</p> <p><u>CO</u>: comparison group which received no tx over 1 month (n = 28)</p>	<p>After 10 mins: ↓ 52mls, 5.8% actual oedema p = 0.004</p>	<p>↓ heaviness p = 0.05 ↓ tightness p = 0.02</p>	<p><u>After 24 hours:</u> ↓ 46mls, 4.3% actual oedema p = 0.04 ↓ tightness p = 0.00 ↓ heaviness p = 0.01</p> <p><u>1 week:</u> ↓ 33mls, 3.5% actual oedema p = 0.03 ↓ heaviness p = 0.01</p> <p><u>1 mth of regime:</u> <u>Tx:</u> ↓ 101mls, 9.0% actual oedema p = 0.07 ↓ heaviness p = 0.00 ↓ limb size p = 0.02</p> <p><u>CO:</u> ↓ 7mls, ~ 0.7% p = 0.975 subjective symptoms p = n.s.</p>	<p>5</p>	<p>Moseley et al (2005)</p>

Table 3.4a. Summary of Results of Exercise Regimes for Limb Lymphoedema (Cont.)

Treatment Protocol	Change	Subjective Symptoms	Follow Up	Quality Score	Reference
<p><u>CO</u>: not described (n = 8)</p> <p><u>Tx</u>: 45mins hydrotherapy exercise 3 x week for 4 weeks (n = 8)</p>	<p>After regime:</p> <p><u>Tx</u>: ↓ 48mls ~ 4.8% p = n.s.</p> <p><u>CO</u>: ↑ 1.2mls ~ 0.1% p = n.s.</p>	<p>aching, limb appearance, heaviness, tightness & work/leisure activities improved in both groups over time</p> <p>heat intolerance, swelling & joint stiffness improved more in exercise group (p < 0.05)</p>	<p><u>Tx</u>:</p> <p>3 wks: ↓ 30mls ~ 3.0%</p> <p>6 wks: ↓ 86mls ~ 8.7%</p> <p>p = n.s.</p> <p><u>CO</u>:</p> <p>3 wks: ↑ 50mls ~ 5.0%</p> <p>6 wks: ↑ 32.5mls ~ 3.4%</p> <p>p = n.s.</p>	4	Box et al (2004)
<p>30 mins of instructed deep breathing, self massage & limb exercises</p> <p>Arms: n = 7</p> <p>Legs: n = 7</p>	<p><u>Arms</u></p> <p>After Tx</p> <p>↑ 12mls, 0.4% actual oedema,</p> <p>20 mins post Tx</p> <p>↓ 24mls, 0.8% oedema, p = n.s.</p> <p><u>Legs</u></p> <p>After Tx</p> <p>↓ 55mls, 5.8% actual oedema,</p> <p>20 mins post Tx</p> <p>↓ 31mls, 3.0% oedema, p = n.s.</p>	<p><u>Arms & Legs</u></p> <p>↓ heaviness</p> <p>↓ tightness</p> <p>↓ size difference</p> <p>↓ temperature difference</p> <p>↓ movement limitation</p> <p>p = n.s.</p>	Nil	4	Buckley et al (2004)

Table 3.4a. Summary of Results of Exercise Regimes for Limb Lymphoedema (Cont.)

Treatment Protocol	Change	Subjective Symptoms	Follow Up	Quality Score	Reference
<p>Study 1: participants performed a 40 minute Hydrotherapy program on 2 occasions. First occasion in water temperature of 28°C (82°F), second at 34°C (93°F) (n = 7)</p> <p>Study 2: participants performed repetitions of shoulder flexion & abduction, elbow extension & flexion using 0.5kg hand weights on 2 occasions. First occasion whilst wearing a compression sleeve, the other whilst not wearing a sleeve (n = 23)</p>	<p>Study 1: <u>28°C</u>: ↓ 32mls (± 50), 12% (± 17) p = 0.06</p> <p><u>34°C</u>: ↑ 2mls (± 48), 7% (± 18) p = n.s.</p> <p>Study 2: - <u>Sleeve</u>: ↑ 10mls, 0.3% p < 0.05 + <u>Sleeve</u>: ↑ 12mls, 0.5% p < 0.05</p>	<p>Study 1: - tension - heaviness</p> <p>Study 2: - tension - heaviness - <u>Sleeve</u>: ↑ physical exertion p < 0.001 + <u>Sleeve</u>: - physical exertion</p>	<p>Study 2: <u>24 Hours</u>: - <u>Sleeve</u>: ↓ 15mls, 0.7% p = n.s. + <u>Sleeve</u>: ↓ 15mls, 1.0% p = n.s.</p> <p>Subjective symptoms not reported</p>	<p>4</p>	<p>Johansson et al (2004)</p>
<p>Participants used an aerobic exerciser which delivered leg elevation and passive exercise, morning & evening for 3wks (n = 33)</p>	<p>After 3wks: ↓ 330mls, ~ 33.0% p = 0.001</p>	<p>↓ pain p = 0.04 ↓ heaviness p = 0.00 ↓ tightness p = 0.00 ↓ skin dryness p = 0.01 ↓ limb size p = 0.00</p>	<p>1 month ↑ 100mls, ~ 10.0% p = n.s. ↑ subjective symptoms, not back to baseline</p>	<p>6</p>	<p>Moseley et al (2004)</p>

Table 3.4a. Summary of Results of Exercise Regimes for Limb Lymphoedema (Cont.)

Treatment Protocol	Change	Subjective Symptoms	Follow Up	Quality Score	Reference
<p><u>CO</u>: compression only (n = 7)</p> <p><u>Tx</u>: exercise regime 3 x wk for 8 wks (n = 7)</p>	<p>After regime:</p> <p><u>Tx</u>: ↓ 2% in vol. p = n.s.</p> <p><u>CO</u>: ↑ 3% in vol. p = n.s.</p>	<p><u>Tx</u>:</p> <p>↑ physical function^g p = 0.05</p> <p>↑ general health p = 0.048</p> <p>↑ vitality p = 0.023</p> <p><u>CO</u>:</p> <p>Above decreased.</p>	<p>Nil</p>	<p>5</p>	<p>McKenzie & Kalda (2003)</p>

Exercise Regimes for Leg Oedema

The study by Moseley et al (2003) involved twenty two participants with leg oedema subsequent to chronic venous insufficiency and had a clear explanation of the inclusion/exclusion criteria and of the treatment regime. This regime was the use of an aerobic exerciser which elevated and passively exercised the legs in the home environment over a 3 week period (see chapter 4 for a detailed description of the machine and treatment schedule). At the end of trial duration, this group experienced a statistically significant reduction in limb volume (220mls ~ 22%) and subjective symptoms such as heaviness, pain, tightness, skin dryness and perceived limb size. In addition, this group also experienced reductions in cramping and burning sensations, which are common complaints in this condition. Interestingly, at 1 month follow up the limb volume reduction was sustained, with subjective symptoms increasing but not returning to pre-treatment levels.

Participants with leg oedema subsequent to varicose veins were involved in a study by Ernst et al (1991) which investigated the benefits of a physical therapy regime undertaken in water. This study had a clear inclusion and exclusion criteria with participants being randomized (technique not described) to either a treatment (n=30) or control group (n = 31). The physical regime (the exact form of exercise undertaken was not described) was performed in intermittent cold and warm water or continuous cold water (temperatures not specified) for 12 minutes, five times a week for 24 days. At the end of this time period the treatment group had a significant leg volume reduction of 36mls (~ 4%), in comparison to the control group which had a non-significant reduction of 13mls (~ 1.3%). Whether it was more beneficial to undertake the regime in intermittent cold and warm water or continuous cold water was not explored. Both groups experienced reductions in subjective symptoms, with the treatment group having greater reductions in cramps, stitches and discomfort when standing.

Interestingly, in a reverse trend, the control group reported a slightly greater reduction in heaviness in comparison to the treatment group.

Although the instigated treatment regime in this trial yielded benefits, the exact exercise regime performed by the treatment group is not described, apart from a brief statement about a 'standardized physical therapy program'. There was also a confounder for this regime as participants who were already wearing compression garments were permitted to continue this wear through out the trial duration. Unfortunately, it is not stated how many participants wore compression and therefore it is unknown what impact this may have had.

The two reviewed studies demonstrate that benefits can be derived from exercise for those with venous oedema of the legs, in terms of limb volume reduction and improvements in subjective symptoms. An explanation of the exact physical regime undertaken in Ernst et al's (1991) study and the number of participants who continued to wear compression garments would have been helpful in translating these results into clinical practice.

Table 3.4b. Summary of Results of Exercise Regimes for Leg Oedema

Treatment Protocol	Change	Subjective Symptoms	Follow Up	Quality Score	Reference
Participants used an aerobic exerciser which delivered leg elevation and passive exercise, morning & evening for 3wks (n = 22)	After 3wks: ↓ 220mls, ~ 22.0% p = 0.034	↓ pain p = 0.01 ↓ heaviness p = 0.02 ↓ tightness p = 0.02 ↓ cramping p = 0.01 ↓ skin dryness p = 0.03 ↓ burning p = 0.00 ↓ limb size p = 0.00	<u>1 month:</u> volume loss maintained at 1 month follow up. ↑ subjective symptoms but not back to baseline.	6	Moseley et al (2003)
<u>CO:</u> no intervention (n = 31) <u>Tx:</u> physical therapy consisting of intermittent cold & warm water or continuous cold water treatments to both lower legs for 12 mins, 5 x wk for 24 days (n = 30)	After regime: <u>Tx:</u> ↓ 36mls, ~ 3.6% p ≤ 0.01 <u>CO:</u> ↓ 13mls, ~ 1.4% p = n.s.	↓ cramps Tx: p ≤ 0.01 Co: p = n.s. b/w: p ≤ 0.01 ↓ stitches Tx: p ≤ 0.05 Co: p = n.s. ↓ itching Tx: p = n.s. Co: p = n.s. ↓ leg elevat ⁿ Tx: p ≤ 0.01 Co: p = n.s. ↓ heaviness Tx: p ≤ 0.01 Co: p ≤ 0.001 ↓ discomfort Tx: p ≤ 0.001 Co: p = n.s. b/w: p ≤ 0.05	Nil	5	Ernst et al (1991)

Elevation for Limb Lymphoedema

Only one study could be found that investigated the effects of elevation on limb lymphoedema. The study by Swedborg et al (1993) involved a sample of 33 women with secondary arm lymphoedema, had a clearly defined inclusion/exclusion criteria and explanation of how the elevation of the limb was achieved. Elevation of the lymphoedema arm over a 5 hour period resulted in significant percentage volume reductions over both the first hour and at the end of the 5 hours (1.3% and 3.1% respectively). No subjective symptoms were recorded and there was no comment on whether there were complaints from having the arm abducted and at an 80° angle for 5 hours and therefore, how well this elevation regime was tolerated.

Elevation for Leg Oedema

A study by Xia et al (2004) investigated the benefit of limb elevation for patients with venous oedema of the legs. The sample group for this study was small (n=4) and poorly defined, with no stated inclusion or exclusion criteria and only a brief statement about patients with 'leg oedema'. Results demonstrated that elevation over 4 hours did result in a small but significant 2.9% reduction in leg volume. However, how the leg elevation was achieved, at what angle it was set at and whether it was tolerable to the patient was not stated. This is a rather significant oversight, as this type of information is important for clinicians who maybe considering recommending leg elevation to their patients.

Table 3.5a. Summary of Results of Elevation for Limb Lymphoedema

Treatment Protocol	Change	Subjective Symptoms	Follow up	Quality Score	Reference
Participant supine, arm supported at 80° and 25° abduction for 5 hours (n = 33)	<p>After 1 hour: ↓ 1.3% (\pm 0.004) in volume p < 0.05</p> <p>After 5 hours: ↓ 3.1% (\pm 0.07) in volume p < 0.05</p>	Not reported	Nil	6	Swedborg et al (1993)

Table 3.5b. Summary of Results of Elevation for Leg Oedema

Treatment Protocol	Change	Subjective Symptoms	Follow up	Quality Score	Reference
Leg elevated over 4 hours (n = 4)	<p>After 4 hours: ↓ 2.9% (\pm 0.06) in volume p < 0.03</p>	Not reported	Nil	5	Xia et al (2004)

Pneumatic Pump Therapy

The study by Dubois (2004) had a sample of sixty two women in the group who received a combination of 0.5 hour of manual lymphatic drainage and 0.5 hour of pump therapy over 25 sessions, but a smaller sample size of fourteen who received 6 hours of sequential (40mmHg) pump therapy (only) over 5 days. Overall, the reporting of this study was generally poor (reflected in a poor quality rating of 2/8), no exclusion criteria was stated, with only a statement of 'those suffering from post mastectomy lymphoedema' being put forth as the inclusion criteria. The type of statistical analysis performed on the data is also not stated nor are any statistical values. Lastly, the interval for follow up measurement and the type of follow up treatment instigated (ie: whether it was MLD, pump therapy or a combination of the both) are not reported.

Both treatment groups in this study experienced identical oedema volume reductions (45%) after the treatment period, with this reduction being achieved over a shorter treatment duration (5 days) in the pump only group. However, considering the pump only group had a sample size of 14, it is hard to determine whether this volume reduction is a true reflection of what can be achieved with this form of sequential (40mmHg) pump. The follow up period (although not defined) did show that when therapy was not continued, the MLD plus pump group experienced an increase in oedema of 33%, whilst the pump only group had 'oedema reoccurrence' from 1 week up to 3 months after treatment cessation. Only those who continued some form of therapy maintained a 1% reduction in oedema.

Szuba et al (2002) performed two randomized, prospective studies involving women with arm lymphoedema which investigated the use of a 4 chambered, sequential pump as an adjunct therapy. Overall, these studies had a clearly defined inclusion/exclusion criteria and explanation of the drop out rates. How randomization was performed was not explained. The first study undertaken compared 10 days of complex physical therapy (CPT) alone (n=11) and in combination with 30 minutes of pump therapy (30-40mmHg) which was instigated after performing the manual lymphatic drainage component of the CPT (n=12). Results showed that the CPT in combination with 30 minutes of pump therapy resulted in a greater and significant limb volume reduction in comparison to CPT alone (45.3% v's 26% respectively). Interestingly, the reduction achieved by the CPT plus pump therapy was not maintained at 1 month follow up (with an increase of 15%), whilst the reduction as a result of CPT alone was maintained (27.1% in comparison to 26% at trial end).

The second study by Szuba et al (2002) involved twenty five women who undertook a 1 month phase of arm self maintenance which included self massage and wearing a compression garment, followed by a 1 month break and then regularly applying 1 hour of pump therapy for a further 1 month period. The phase where self massage and a compression garment were instigated resulted in an arm volume increase of 32.7mls (~ 3.3%), with the addition of the 1 hour of pump therapy resulting in a statistically significant reduction of 89.5mls (~ 9.0%). At trial end participants were given the opportunity to continue the use of the pump over the next 6 months. Follow up at this time showed that the pump therapy had been instigated, on average, 4 times a week. From this, 19 participants had had an additional reduction (in comparison to trial end) in limb volume of 29.1mls (~ 3.0%), whilst 5 had had an increase of 35mls (~ 3.5%). Why this sub-group of participants had a worsening in limb volume was not explored.

The study by Bergan et al (1998) investigated 3 different pump types (non-gradient uni-compartmental, non-gradient 3 compartmental and gradient multi-compartmental) on 24 participants with secondary leg lymphoedema. These participants were divided into 2 treatment groups, the first (14) consisted of those who had also undergone radiotherapy treatment and the second (10) consisted of those who had not. The study included randomization and an explanation of the drop out rate but had no stated inclusion/exclusion criteria. Although the pumps were applied for 2 hours at a time, the overall treatment period was not stated.

Out of the three pumps applied to the two groups, the multi-compartmental pump with the graduated pressure (80–30mmHg) was the most effective in terms of percentage volume reduction, the reduction at end of trial being 32.4% in those who had not undergone radiotherapy and 29.2% in those who had. These percentage reductions were also statistically significant in comparison to the other two uni-compartmental pumps investigated. The fact that those who had not undergone radiotherapy had a slightly better result maybe related to less tissue fibrosis in this group, but this was not formally measured or explored in this trial.

Women with arm lymphoedema were involved in a randomized study by Johanssen et al (1998) which had a clearly stated inclusion/exclusion criterion, a good explanation of the drop out rate and a sample size of twelve. This study investigated the effects of wearing a class II compression garment for 2 weeks followed by 2 hours of pump therapy (40-60mmHg), five days a week for a further 2 weeks. After wearing a compression sleeve alone for 2 weeks there was a statistically significant volume reduction of 49mls (7%) in comparison to 2 weeks of pump therapy which yielded a non significant reduction of 28mls (7%). The wearing of a compression garment also resulted in statistically significant reductions in tension and

heaviness and although there were reductions in these parameters during the pump therapy, they were not statistically significant. In this particular sample, the wearing of the compression garment appeared to be of more benefit in comparison to the pump therapy.

The study by Swedborg (1984) involved 54 women with arm lymphoedema who underwent a phase of control (average 4 weeks), wearing a class II (30-40mmHg) compression garment (6 months) and then receiving 6 hours of pump therapy over 10 sessions followed by wearing a compression garment. The study had a good inclusion and exclusion criteria but no explanation of the drop out rate. The results showed that there was a non-significant 1.5% oedema reduction after the control period, a significant 8% reduction after wearing the compression garment and an additional 9% significant reduction after the pump therapy (with the assumption that the total edema reduction at this time point was 17%). However, it is hard to determine whether the reduction after the pump therapy is in comparison to baseline, the end of the control period or the end of the compression sleeve period (as this is not stated). Six months after pump therapy, twenty nine women who had continued to wear the compression garment were followed up, with results showing a reduction of 19.8%. This reduction is similar to the net reduction at the end of the treatment period (17%). These results indicate that continuing to wear the compression garment helped to maintain the initial reduction achieved from the pump therapy.

Twenty five women with arm lymphoedema were involved in Zelikovski et al's (1980) study which involved 2-3 hours of sequential (100-150mmHg) pump therapy, three times a day for three days. No inclusion or exclusion criteria were stated for this study, drop outs were not mentioned and the form of statistical analysis used was not described. After 3 days of receiving pump therapy the group experienced a percentage reduction which ranged from 12 - 44%, with

the greatest reduction occurring in those participants with the biggest limbs and therefore the greatest amount of oedema volume. Statistical values are not stated so it is not known whether the reductions are statistically significant. This group also undertook maintenance therapy after the trial which consisted of 2 hours of the same pump administered 1 – 4 times a week over a 6 month period. Follow up at the 6 month time point showed that the initial reductions from treatment had been maintained (actual percentage reduction is not stated). However, it was not reported whether the maintenance of limb volume was the result of 1 or 4 sessions of treatment per week.

The study by Bergen et al (1998) demonstrated that the multi-compartmental pump was the most effective in reducing percentage oedema, which maybe related to the graduated pressure and centripetal massaging effect that the pump achieves. The highest pressure used in this trial (around the lower leg) was 80mmHg, which is above the 60mmHg of pressure recommended for lymphoedema limbs (Eliska & Eliskova 1995). High pressures (100-150mmHg) were also used in Zelikovski et al's (1980) study, with 6 patients complaining of pain after the treatment regime. The fact that Bergen et al's (1998) study does not state the treatment duration also makes it impossible to know what duration of treatment would be most effective for this population.

Three of the studies reviewed (Dubois 2004; Szuba et al 2002; Swedborg 1984) demonstrated that better results in volume reduction were achieved when pump therapy was combined with other forms of therapy, including; manual lymphatic drainage, compression garments and self massage. The studies by Dubois (2004), Swedborg (1984) and Zelikovski et al (1980) also demonstrated that continuing the pump therapy or wearing a compression garment were equally as beneficial in maintaining the initial reductions obtained from the trial.

Table 3.6. Summary of Results of Pneumatic Pump Therapy

Treatment Protocol	Change	Subjective Symptoms	Follow Up	Quality Score	Reference
<p><u>Grp A:</u> 0.5hr pump @ 40mmHg followed by 0.5hr MLD for 25 sessions (n = 62)</p> <p><u>Grp B:</u> 6hrs of sequential pump treatment (40mmHg) for 5 days (n = 14)</p>	<p><u>Grp A:</u> ↓ 45% in oedema vol.</p> <p><u>Grp B:</u> ↓ 45% in oedema vol.</p> <p>p values not stated</p>	Not reported	<p><u>Grp A:</u></p> <p>↑ 33% in oedema vol in those who had no f/up treatment</p> <p>↓ 1% in those who had f/up treatment</p> <p><u>Grp B:</u></p> <p>Oedema re-occurrence at 1wk - 3mths</p>	2	DuBois (2004)
<p>Study 1:</p> <p><u>Grp A:</u> MLD + 30 mins of pump therapy (40-50mmHg) then bandaging for 10 days (n = 12)</p> <p><u>Grp B:</u> CPT minus pump therapy (n = 11)</p> <p>Both groups wore a compression garment & performed self massage</p> <p>Study 2:</p> <p><u>Grp C:</u> Daily self massage + compression garment for 1month</p> <p><u>Grp D:</u> Daily self massage followed by 1 hour of pump therapy + compression garment for 1mth (n = 25)</p>	<p>Study 1:</p> <p>After 10 days:</p> <p><u>Grp A:</u> ↓ 45.3% (± 18.2) in vol.</p> <p><u>Grp B:</u> ↓ 26.0% (± 22.1) in vol.</p> <p>Grp A v's B p < 0.05</p> <p>Study 2:</p> <p><u>Grp C:</u> ↑ 32.7mls (± 115.2)</p> <p><u>Grp D:</u> ↓ 89.5mls (± 195.5)</p> <p>p < 0.05</p>	Not reported	<p>Study 1:</p> <p><u>1 mth:</u></p> <p><u>Grp A:</u> 30.3% in vol.</p> <p><u>Grp B:</u> 27.1% in vol.</p> <p>p = n.s.</p> <p>Study 2:</p> <p><u>6mths:</u></p> <p><u>Grp D:</u> 19 had additional ↓ 29.1mls, ~ 3.0%</p> <p>5 had ↑ 35mls, ~ 3.5%</p>	6	Szuba et al (2002)

Table 3.6. Summary of Results of Pneumatic Pump Therapy (Cont.)

Treatment Protocol	Change	Subjective Symptoms	Follow Up	Quality Score	Reference
<p><u>Tx 1</u>: unicompartmental non-gradient pump (50mmHg)</p> <p><u>Tx 2</u>: 3 compartment with segmental non-gradient pump (50mmHg)</p> <p><u>Tx 3</u>: multicompartmental gradient with 10 cells ranging from 80mmHg (distal) to 30mmHg (proximal)</p> <p>L/O (- RTx): n = 10</p> <p>L/O (+ RTx): n = 14</p>	<p>L/O (- radiotherapy):</p> <p><u>Tx 1</u>: ↑ 0.8% (± 5.9) in vol.</p> <p><u>Tx 2</u>: ↓ 7.7% (± 7.3) in vol.</p> <p><u>Tx 3</u>: ↓ 32.5% (± 15.1) in vol.</p> <p>p < 0.05 Tx 3 v's Tx 1 & Tx 2</p> <p>L/O (+ radiotherapy):</p> <p><u>Tx 1</u>: ↑ 1.6% (± 5.4) in vol.</p> <p><u>Tx 2</u>: ↓ 5.0% (± 9.44) in vol.</p> <p><u>Tx 3</u>: ↓ 29.2% (± 12.2) in vol.</p> <p>p < 0.05 Tx 3 v's Tx 1 & Tx 2</p>	<p>Not reported</p>	<p>Nil</p>	<p>4</p>	<p>Bergan et al (1998)</p>
<p>2 weeks compression sleeve followed by pump (9 comprⁿ cells 40–60mmHg) for 2 hours a day, 5 days/wk for 2wks (n = 12)</p>	<p><u>After sleeve alone</u>:</p> <p>↓ 49mls (± 87mls) p = 0.01</p> <p>↓ 7% (± 18%) in vol. p = 0.05</p> <p><u>Pump</u>:</p> <p>↓ 28mls, p = 0.03</p> <p>↓ 7% in vol. p = n.s.</p>	<p><u>After sleeve alone</u>:</p> <p>↓ tension p = 0.004</p> <p>↓ heaviness p = 0.01</p> <p><u>Pump</u>:</p> <p>n.s. reduction in tension & heaviness</p>	<p>Nil</p>	<p>5</p>	<p>Johansson et al (1998)</p>

Table 3.6. Summary of Results of Pneumatic Pump Therapy (Cont.)

Treatment Protocol	Change	Subjective Symptoms	Follow Up	Quality Score	Reference
Control period (mean 4wks), then compression sleeve (30-40mmHg) for 6 months, then intermittent pump (35-60mmHg) for 6 hours x 10 sessions, then compression sleeve for 6 months (n = 54)	<p><u>Control:</u> ↓ 1.5% in oedema p = 0.703</p> <p><u>Sleeve – end of Tx:</u> ↓ 8% in oedema p = 0.025</p> <p><u>Pump – end of Tx:</u> ↓ 9% in oedema p = 0.025</p>	Not reported	<u>6mths:</u> ↓ 19.8% in oedema p = 0.308	5	Swedborg (1984)
2 - 3hrs sequential pump (100-150mmHg) sessions 3 x day over 3 days. Maintenance of 2 hours of pump therapy 1-4 x week for 6 months (n = 25)	<p>After 3 days of Tx:</p> <p>Pts. with < 35% oedema: ↓ 12% in vol.</p> <p>Pts. with 36-50% oedema: ↓ 36% in vol.</p> <p>Pts. with 51-70% oedema: ↓ 44% in vol.</p>	Not reported	Results constant at 6mth f/up.	4	Zelikovski et al (1980)

Low Level Laser Therapy

The study by Carati et al (2003) involved 64 women with secondary arm lymphoedema and had a good description of the randomization and blinding techniques used and of the active and placebo treatments instigated (this was reflected in a high quality rating of 8/10). The study involved one group which received two cycles of active laser 3 times a week for three weeks each time (n = 37) and another group who received one cycle of placebo laser and one cycle of active laser (n = 27) over the same time periods.

At the end of the initial treatment period those who received 2 laser cycles had a 25ml (~ 2.5%) volume reduction, 1 laser cycle had a 15mls (~ 1.5%) reduction whilst the placebo cycle had a 35mls (~ 3.5%) reduction. Greater volume reduction was observed in the 2 laser cycles at the 3 month follow up, with a significant reduction of 90mls (~ 9.0%), whilst the 1 laser cycle had a reduction of 10mls (~ 1.0%) and the placebo cycle had an increase of 30mls (~ 3.0%). The mean perceptual score was significantly reduced after treatment in all groups, whether they received 1 or 2 active laser cycles or placebo laser. By the 3 month follow up the most significant reductions were in the group who received 2 cycles of active laser, this was particularly so for mean perceptual score and quality of life. In this particular study, 2 cycles of laser therapy overall were superior to 1 cycle or placebo laser.

The study by Piller & Thelander's (1996) involved ten women with secondary arm lymphoedema, had a good inclusion/exclusion criterion and a clear explanation of the treatment regime instigated. Each participant received 10 minutes of scanning laser to the axilla, upper arm and forearm twice a week for 6 weeks and then once a week for a further 4 weeks. Results showed that after 10 weeks of laser therapy there was a volume reduction of 19.3% and progressive improvements in pins & needles, aches & pains and heaviness &

tension. It is stated that these reductions were statistically significant, but no statistical values accompany the data.

The follow up study of this group performed by Piller & Thelander (1998) also had a good description of the sample and the measurement interval undertaken. The data shows continuing volume reductions at the 6 and 36 month follow up points (397mls, 41% and 288mls, 30% respectively). The type of statistical analysis performed on the follow up data and the statistical values are not stated. The subjective data demonstrates that at 36 months follow up most of the subjective symptoms had returned to pre-treatment levels, despite the reduction in limb volume. Two participants were also lost at the follow up points, which left a smaller sample of eight.

The laser studies by Carati et al (2003) and Piller & Thelander (1996 & 1998) demonstrate that benefits including volume reduction, improved subjective symptoms and quality of life can be derived from using low level laser therapy, whether it be a whole scanning laser applied to the axilla, upper arm and forearm or a handheld laser applied to the axilla alone. The best results in Carati et al's (2003) study were seen at 3 months post treatment, which suggests that there maybe ongoing benefits from laser therapy. This is supported by Piller & Thelander's (1998) study (albeit with a much smaller sample size), which found that there were continued reductions in arm volume and reported arm tightness 6 months after therapy cessation.

Table 3.7. Summary of Results of Low Level Laser Therapy

Treatment Protocol	Change	Subjective Symptoms	Follow Up	Quality Score	Reference
<p><u>Grp A:</u> active laser 3 x week for 3 weeks then 3 month wash-out. Then active laser 3 x week for 3 weeks. (n = 37)</p> <p><u>Grp B:</u> placebo laser 3 x week for 3 weeks then 3 month wash- out. Then active laser 3 x week for 3 weeks. (n = 27)</p> <p>Each laser session involved 17 minutes of laser applied to the axilla via a grid.</p>	<p>After regime:</p> <p>2 x cycles laser: ↓ 25mls ~ 2.5%</p> <p>1 x cycle laser: ↓ 15mls ~ 1.5%</p> <p>Placebo: ↓ 35mls ~ 3.5%</p> <p>p = n.s. for all Tx</p>	<p>After regime:</p> <p><u>2 x cycles:</u> ↓ QOL p = n.s.</p> <p>↓ ADLs p = n.s.</p> <p>↓ MPS* p < 0.01</p> <p><u>1 x cycle:</u> ↓ QOL p < 0.05</p> <p>↓ ADLs p = n.s.</p> <p>↓ MPS p < 0.01</p> <p><u>Placebo:</u> - QOL p = n.s.</p> <p>↓ ADLs p = n.s.</p> <p>↓ MPS p < 0.01</p> <p>*MPS = mean perceptual score</p>	<p>1 mth:</p> <p><u>2 x cycles:</u> ↓ 50mls ~ 5.0%</p> <p>↓ QOL p = n.s.</p> <p>↓ ADLs p < 0.05</p> <p>↓ MPS p < 0.01</p> <p><u>1 x cycle:</u> ↓ 15mls ~ 1.5%</p> <p>↑ QOL p = n.s.</p> <p>↑ ADLs p = n.s.</p> <p>↓ MPS p < 0.01</p> <p><u>Placebo:</u> ↓ 5mls ~ 0.6%</p> <p>- QOL p = n.s.</p> <p>↓ ADLs p < 0.05</p> <p>↓ MPS p < 0.01</p> <p>3 mths:</p> <p><u>2 x cycles:</u> ↓ 90mls ~ 9.0%</p> <p>↓ QOL p < 0.05</p> <p>↓ ADLs p = n.s.</p> <p>↓ MPS p < 0.01</p> <p><u>1 x cycle:</u> ↓ 10mls ~ 1.0%</p> <p>↓ QOL p = n.s.</p> <p>- ADLs p = n.s.</p> <p>↓ MPS p = n.s.</p>	<p>8</p>	<p>Carati et al (2003)</p>

Table 3.7. Summary of Results of Laser Therapy (Cont.)

Treatment Protocol	Change	Subjective Symptoms	Follow Up	Quality Score	Reference
			<p><u>Placebo:</u> ↑ 30mls ~ 3.0% ↓ QOL p = n.s. - ADLs p = n.s. ↓ MPS p < 0.05</p>	8	Carati et al (2003)
<p>10 minutes to axilla, upper arm & forearm 2 x week for 6 weeks, then 1 x wk for further 4 weeks (n = 10)</p>	<p>After Tx: ↓ 19.3% (± 19.5%) in vol. p value not stated</p>	<p>Progressive improvement in pins/needles, aches/pains, tension & heaviness. Statistical significant, p values not stated</p>	<p>Nil (see study below)</p>	5	Piller & Thelander (1996)
<p>Post treatment follow up (1-36 months) after 10 minutes of laser to axilla, upper arm & forearm 2 x week for 6 weeks, 1 x wk for further 4 weeks. Given general information on lymphoedema ‘dos’ & ‘don’ts’ (n = 8)</p>	<p>6 months: ↓ 397mls (41% in vol.) 36 months: ↓ 288mls (30% in vol.)</p>	<p>6 months: ↓ tightness ↑ cramps 36 months: ↑ aches & pains ↑ burning ↑ tightness ↑ heaviness</p>	-	5	Piller & Thelander (1998)

Pharmaceuticals for Limb Lymphoedemas

The study by Burgos et al (1999) involved women with arm lymphoedema and had a good inclusion/exclusion criteria and explanation of the drop out rate. This study investigated the effect of two different dosages of Coumarin taken over a 12 month period, with one group taking a 90mg dose (n=23) and the other taking 135mgs (n=30). At trial end, both groups experienced a similar reduction in percentage limb volume (14.9% and 13.2% respectively). Overall, 7 patients (13.2%) from this trial complained of gastric upset after taking the Coumarin.

Although it is stated that there was no statistical difference in the percentage reduction between the two treatment groups, it does not state whether the reduction was statistically significant within the treatment groups. The results state that there were also reductions in heaviness and pain plus cramps, but it is not stated whether these reductions are for the separate groups or the whole sample group combined. There was no follow up period in this study so it is not known whether the reductions in percentage volume and symptoms were maintained. Overall it would appear that both Coumarin dosages (90mg & 135mgs) yielded similar results.

Women with secondary arm lymphoedema were also involved in Loprinzi et al's (1999) study, which was a cross-over trial that investigated a group (n = 67) who took Coumarin 400mgs for 6 months and then placebo for 6 months, and another group (n = 71) who took the placebo first followed by the Coumarin. There was a clear outline of the inclusion and exclusion criteria for this study, the dropout rate and adverse effects. Results from each phase demonstrated an increase (and therefore worsening) of arm volume, with the treatment phase resulting in a 58mls (~ 5.8%) increase and the control phase a 21mls (~ 2.1%) increase.

Although the results in this study state that there was no carry-over effect from the active (Coumarin 400mgs) treatment, the actual wash-out period is not stated. There were also no statistical values accompanying the volume increases, so it is not known whether they were statistically significant or not, both within the groups and between groups. However, possible covariates are considered and included in the analysis to try and explain the increased limb volume in the treatment group. Subjective symptoms are also considered in this study and it is stated that both groups experienced positive improvements in perceived swelling, pressure, tightness, heaviness and mobility. One again, no statistical values accompany these changes, so it is not known whether these subjective improvements were statistically significant.

Pecking et al's (1997) study involved women with secondary arm lymphoedema who either took Daflon (Diosmin plus Hesperidin 1,000mgs) for 6 months (n=46) or placebo for 6 months (n=48). No exclusion criterion is given for this trial, and even though the number of women who entered and completed the study are stated, it is not clear whether the participants who did not complete the trial were withdrawn due to adverse effects or whether they withdrew voluntarily. The age of the two groups in the study were also statistically significantly different (61.5yrs versus 57.3yrs, $p = 0.039$), but whether this had an impact upon the overall results is not stated or explored. Results showed that the treatment group experienced a volume reduction of 7% whilst the placebo group experienced an increase in volume of 10%. Both groups experienced a significant reduction in reported arm discomfort, whilst only the treatment group had a significant reduction in arm heaviness. Overall, Daflon (1,000mgs) reduced limb volume and arm heaviness in comparison to placebo.

The study by Cluzan et al (1996) involving women with arm lymphoedema had an extensive explanation of the inclusion and exclusion criteria and stated the adverse effects and study withdrawals. The study involved a group (n=27) who took 3 capsules of Cyclo-fort (Ruscus Aculeatus and Hesperidin Methyl Chalcone) 3 times a day for 3 months and a group (n=30) who took an equivalent placebo over this time period. Both groups also received MLD twice a week for 'at least' 1 month. However, the amount of MLD administered each time to the patient is not known.

It is interesting to note that the participants with mild lymphoedema in the placebo group experienced more oedema reduction after the first month of the trial in comparison to the participants with mild lymphoedema in the treatment group (8.8% compared to 3.3%), whether this is related to the administration of MLD during this time period is not explored. After this time, the reductions in oedema are only seen to occur in the Cyclo-Fort treatment group, with an overall significant reduction of 8.5% at 2 months and 12.9% at 3 months. This is in comparison to the placebo group who increased by 1.2% and 2.5% at these time points. Both groups experienced improvements in heaviness and limb mobility, with the reductions being greater and significant in the Cyclo-Fort group. Between group statistics are not stated so it is not known whether the reductions in oedema and symptoms in the Cyclo-Fort group are statistically significant in comparison to the placebo group.

Casley-Smith et al's (1993) cross-over study involved 31 women with arm lymphoedema and had a high quality rating (8/10), a good explanation of the inclusion/exclusion criteria, randomization technique and compliance monitoring. The first group (n=18) in this trial took 5-6 Benzo- α -pyrone (200mgs) for 6 months followed by a placebo tablet for 6 months, whilst the second group (n=13) took the placebo first followed by the 5-6 Benzo- α -pyrone. Combined

results demonstrated that the treatment phase resulted in a large limb volume reduction of 840mls (35.6%), with this reduction being significant in comparison to the control phase, which resulted in a volume increase of 490mls (41.6%). The treatment phase also resulted in significant improvements in subjective symptoms such as heaviness, tightness and burning in comparison to the placebo phase, where these parameters only improved slightly. Seven patients (22.6%) taking the 5-6 Benzo- α -pyrone (200mgs) reported mild nausea or diarrhea but did not withdraw from the study. At 1 month follow up there was an additional decrease in percentage oedema (3.3%) from the treatment phase compared to the placebo phase which had an additional increase of 1.2%, indicating that this 5-6 Benzo- α -pyrone preparation may have ongoing benefits.

The two studies in this review which investigated the effects of Coumarin in women with secondary arm lymphoedema had conflicting results. The study by Burgos et al (1999) investigating two dosages (90mg and 150mgs) of Coumarin demonstrated percentage volume reductions, whilst Loprinzi et al (1999) demonstrated a volume increase in those who took 400mgs of Coumarin. As neither study had a follow up period it is not known whether the initial volume reduction or increase would have continued. The other reviewed studies (Pecking et al 1997; Cluzan 1996; Casley-Smith 1993) demonstrated that varying volume reductions and subjective improvements could be obtained from oral pharmaceuticals such as Daflon (1,000mgs) and Cyclo-fort, with the greatest limb reduction (840mls, 35.6%) being obtained from the 5-6 Benzo- α -pyrone (200mgs), which was maintained at 1 month follow up.

Table 3.8a. Summary of Results of Oral Pharmaceuticals for Limb Lymphoedemas

Treatment Protocol	Change	Subjective Symptoms	Follow Up	Quality Score	Reference
<p><u>Grp A:</u> Coumarin 90mg/day (n = 23)</p> <p><u>Grp B:</u> Coumarin 135mg/day (n = 30)</p> <p>Duration: 12months</p>	<p>End of regime:</p> <p><u>Grp A:</u> ↓ 14.9% in vol.</p> <p><u>Grp B:</u> ↓ 13.2% in vol.</p> <p>Within grp statistics not stated. B/w groups; p = 0.122</p>	<p>↓ Heaviness p < 0.0005</p> <p>↓ Pain + cramps p < 0.0005</p>	Nil	7	Burgos et al (1999)
<p><u>Tx:</u> Coumarin, 2 x 100mg, 2 x day followed by lactose tablets, 2 x tabs, 2 x day (n = 67)</p> <p><u>CO:</u> Lactose tablets, 2 x tabs, 2 x day followed by Coumarin, 2 x 100mg, 2 x day (n = 71)</p> <p>Duration: 6 months for each phase</p>	<p>Groups combined:</p> <p><u>Tx:</u> ↑ 58mls ~ 5.9%</p> <p><u>CO:</u> ↑ 21mls ~ 2.1%</p> <p>p value not stated</p>	<p>Both Grps:</p> <p>↓ swelling ↓ pressure</p> <p>↓ tightness ↓ heaviness</p> <p>↓ mobility</p>	Nil	7	Loprinzi et al (1999)
<p><u>Tx:</u> Daflon, 2 x 500mg, 1 x day (n = 46)</p> <p><u>CO:</u> Placebo, 2 tabs, 1 x day (n = 48)</p> <p>Duration: 6 months</p>	<p>End of regime:</p> <p><u>Tx:</u> ↓ 7% in volume</p> <p><u>Co:</u> ↑ 10% in volume</p> <p>As interpreted from the graph</p>	<p><u>Tx:</u></p> <p>↓ heaviness p = 0.035</p> <p>↓ discomfort p < 0.001</p> <p><u>CO:</u></p> <p>↓ discomfort p = 0.002</p>	Nil	4	Pecking et al (1997)

Table 3.8a. Summary of Results of Oral Pharmaceuticals for Limb Lymphoedemas (Cont.)

Treatment Protocol	Change	Subjective Symptoms	Follow Up	Quality Score	Reference
<p><u>Tx:</u> 3 capsules of Cyclo-3- Fort (bioflavonoid), 3 x a day + MLD 2 x week for at least 1 month (n = 27)</p> <p><u>CO:</u> 3 placebo capsules, 3 x a day + MLD 2 x a week for at least 1 mth (n = 30)</p> <p>Duration: 3 months</p>	<p><u>After 1 month Tx:</u> Mild LO: ↓ 3.5% in oedema Mod LO: ↓ 0.3% in oedema Total: ↓ 1.2% in oedema p: n.s.</p> <p><u>CO:</u> Mild LO: ↓ 8.8% in oedema Mod LO: ↑ 0.3% in oedema Total: ↓ 0.5% in oedema p: n.s.</p> <p><u>After 2 months Tx:</u> Mild LO: ↓ 17.1% in oedema Mod LO: ↓ 5.5% in oedema Total: ↓ 8.5% in oedema p: 0.03</p> <p><u>CO:</u> Mild LO: ↑ 0.5% in oedema Mod LO: ↑ 0.3% in oedema Total: ↑ 1.2% in oedema p: n.s.</p>	<p><u>Tx:</u> ↑ softness p = 0.01 ↓ heaviness p = 0.02 ↑ mobility p = 0.01</p> <p><u>CO:</u> ↓ softness p = n.s. ↓ heaviness p = n.s. ↑ mobility p = n.s.</p>	<p>Nil</p>	<p>7</p>	<p>Cluzan et al (1996)</p>

Table 3.8a. Summary of Results of Oral Pharmaceuticals for Limb Lymphoedemas (Cont.)

Treatment Protocol	Change	Subjective Symptoms	Follow Up	Quality Score	Reference
	<p><u>After 3 months:</u></p> <p><u>Tx:</u> Mild LO: ↓ 20.7% in oedema Mod LO: ↓ 10.3% in oedema Total: ↓ 12.9% in oedema p: 0.009</p> <p><u>CO:</u> Mild LO: ↑ 0.6% in oedema Mod LO: ↑ 1.9% in oedema Total: ↑ 2.5% in oedema p: n.s.</p>			7	Cluzan et al (1996)
<p><u>Tx:</u> Benzopyrone 200mg/ day followed by equilivent placebo (n = 18)</p> <p><u>CO:</u> Equilivent placebo followed by Benzopyrone 200mg/day (n = 13)</p> <p>Duration: 6 months each phase</p>	<p>End of whole trial:</p> <p><u>Tx:</u> ↓ 840mls, 35.6% in oedema</p> <p><u>CO:</u> ↑ 490mls, 41.6% in oedema</p> <p>B/w Grps p < 0.001</p>	<p><u>Tx:</u> ↓ Heaviness ↓ Tightness ↓ Burning</p> <p>B/w Grps p < 0.001</p>	<p><u>1 month:</u> <u>Tx:</u> ↓ 3.3% <u>CO:</u> ↑ 1.2%</p> <p>B/w Grps p < 0.001</p>	8	Casely-Smith et al (1993)

Oral Pharmaceuticals for Leg Oedema

The study by Vanscheidt et al (2002) involved both women and men with chronic venous insufficiency and subsequent leg oedema. It had a detailed inclusion and exclusion criteria, a good explanation of the drop out rate and an explanation of the randomization technique. This study involved two groups who underwent a number of different treatment phases. The first group (n=114) received 2 weeks of compression bandaging, followed by oral SB-LOT (90mgs Coumarin/540mgs Troxerutin per day) and the wearing of compression stockings (type not specified) for four weeks, the compression stockings were then ceased but the SB-LOT was continued for a further 12 weeks. The second group (n=117) underwent the same regime but took a placebo tablet in place of the SB-LOT.

The results section of this trial had detailed descriptive statistics of both groups, with one disparity being between the group ages, with the mean age of the treatment group being 54.9yrs compared to 22.3yrs for the control group. Although this appears to be quite a discrepancy, it is not commented upon in the research findings. A limb volume reduction was achieved by applying compression bandaging alone (100mls ~ 10% and 110mls ~ 11% respectively), with both groups having the same amount of volume reduction with compression + SB-LOT or placebo (120mls ~ 12%) and similar reductions when taking the SB-LOT or placebo alone (95mls ~ 9.5% and 85mls ~ 8.5%). Unfortunately no statistical values are reported, so it is unknown whether these volume reductions were statistically significant, both within the group and between groups.

Both groups experienced reductions in reported heaviness, tiredness, tension, tingling, itching and burning, with these reductions being statistically significant in the SB-LOT group in comparison to the placebo group. At the 1 month follow up the leg volume had only increased

slightly in the SB-LOT group (6.5mls ~ 0.7%), with the placebo group having a greater increase of 36.7mls (~ 3.7%), which was statistically significant in comparison. Overall, during the treatment phase similar volume reductions were obtained in both groups, with the treatment group having greater improvements in subjective symptoms. The slight volume increase in the treatment group at 1 month follow up may indicate that there are ongoing benefits from SB-LOT.

The study by Nocker et al (1999) involved women with leg oedema caused by chronic venous insufficiency who took different strengths (600mgs, 900mgs, 1,200mgs or 1,500mgs per day) of O-(β -Hydroxyethyl)-Rutoside (Oxerutin) or placebo over 3 months, with 6 women being allocated to each group. The study had a good inclusion and exclusion criteria, randomization and double blinding, but how these two techniques were achieved is not stated. At the end of trial duration there had been small reductions in limb volume in all treatment groups (10 – 18mls, ~ 1-2%), with the greatest reduction of 18mls being achieved by the 1,200mgs dosage. In comparison, the placebo group increased in limb volume by 2mls (~ 0.2%). No statistical values accompany the dosage reductions or placebo increase. It is stated that all the treatment groups had a reduction in ‘subjective symptoms’ in comparison to the placebo group, however, exactly which symptoms were improved is not stated. At 1 month follow up there were similar volume reductions (9-15mls, ~ 0.9-1.5%) in the treatment groups and an increase of 2mls (~0.2%) in the placebo group. Whether these reductions (or increase, in the case of the placebo group) are in comparison to the baseline or end of trial value is not stated. The change in subjective symptoms at this time point was not reported.

Participants with substantial lower leg oedema due to chronic venous insufficiency were involved in Diehm et al's (1996) study, which was a randomized, placebo controlled trial that had a good explanation of the inclusion and exclusion criteria. It is stated that the study was 'partially' blinded, but how this blinding was achieved is not explored. The study involved a group (n=99) who underwent 2 weeks of no treatment then 1 week of taking an oral diuretic (Hydrochlorothiazide 25mgs/Triamterence 50mgs per day) followed by the wearing of a class II compression garment for 9 weeks. The second group (n=95) underwent 2 weeks of no treatment followed by 10 weeks of oral HCSE (Venostasin Retard 100mgs/Aescin 100mgs per day), whilst the third group (n=46) underwent 2 weeks of no treatment followed by 10 weeks of a placebo tablet. Why there is such a disparity in the placebo group number (n=46) in comparison to the two treatment groups (n=99 and 95) is not explained, nor is the withdrawal and drop out rate stated.

Results for this trial were only reported for the end of each treatment regime, so the effect of no treatment and 7 days of an oral diuretic are not known. At the end of trial duration, the group who wore grade II compression only and the group who took oral HCSE had similar reductions in limb volume (43.3mls ~ 4.3% and 46.7mls ~ 4.7% respectively). These reductions were statistically significant in comparison to the placebo group which had an increase in volume of 9.8mls (~ 1.0%). The fact that the limb volume reductions were similar in both treatment groups suggests that taking HCSE twice a day is equivalent to (but not superior to) taking a diuretic once a day for 1 week and then wearing a grade II compression stocking. There was no follow up period in this study so it is not known whether the limb volume reductions were maintained.

Rehn et al's (1996) study investigated the effects of different oral preparations and placebo in women with chronic venous insufficiency and subsequent leg oedema. The first group (n=59) took a placebo for 1 week followed by Oxerutin (1,000mgs per day) for a further 12 weeks. The second group (n=37) took 1 week of placebo followed by Oxerutin (1,000mgs per day) for 4 weeks which was reduced to 500mgs per day for a further 8 weeks. The last group (n=62) also took a placebo for 1 week followed by Horse Chestnut (600mgs per day) for a further 12 weeks.

Results of this trial are also only reported for the end of each treatment regime, so the effect of taking a placebo for 1 week is not known. At the end of the regimes, Oxerutin 1,000mgs (for 12 weeks) achieved the greatest volume reduction of 57.9mls (~ 5.8%) followed by 40.2mls (~ 4.1%) achieved by the combination of Oxertin 1,000mgs and 500mgs. The least volume reduction (28.2mls ~ 2.8%) was achieved by the Horse Chestnut (600mgs). All groups experienced reductions in leg tiredness, heaviness and tension, with only the groups who took Oxerutin experiencing a reduction in tingling. The six week follow up measurement demonstrated that some of the volume reduction achieved by the different preparations had been maintained (Oxerutin 1,000mgs – 46.4mls, 4.6%; Oxerutin 1,000 & 500mgs – 21.1mls, 2.1%; Horse Chestnut – 26mls, 2.6%), as had the improvements in leg tiredness, heaviness and tension. There are no accompanying statistical values at any time points, so significance is not known, both for within the treatment groups and between them.

Women with persistent leg oedema subsequent to chronic venous insufficiency were involved in a study by Unkauf et al (1996) which investigated the wearing of grade II compression in combination with taking oral Oxerutin 500mgs per day (n=64) or placebo (n = 56). This study had a detailed inclusion and exclusion criteria, an explanation of the withdrawal and drop out

rate and clear descriptive statistics, so it could be easily determined that the two groups were comparable. At the end of 12 weeks there had been a significant limb volume reduction of 63.9mls (~ 6.4%) in the group who took Oxerutin (500mgs) plus wore compression in comparison to a 32.9mls (~ 3.3%) reduction in those who took placebo and wore compression. Both groups had similar reductions in the subjective symptoms of tiredness, heaviness, tingling and tension, which may suggest that this is the result of the compression stockings and not the Oxerutin. As there are no statistical values stated for these subjective reductions it is not known whether they are statistically significant or not.

The Oxerutin (500mg) + compression group had continuing leg volume reductions at both the 3 and 6 week follow up periods (35.4mls ~ 3.5% and 32.2mls ~3.2% respectively), which may indicate an ongoing benefit of Oxerutin. The placebo group had a small volume increase (8.6mls ~ 0.9%) at 3 weeks follow up but this was reversed at 6 weeks follow up (reduction of 8.3mls, ~ 0.8%). Interestingly, the placebo group had little increase in reported subjective symptoms (such as tension) at these time points (in comparison to the treatment group).

Nuemann & van den Broek's (1995) study involved participants with vascular oedema caused by chronic venous insufficiency who were randomised to either taking O-(β -Hydroxy-Ethyl)-Rutosides (HR) 1,000mgs per day for 4 months (n = 11) or to wearing class II compression stockings for 4 months (n = 12). The study had a detailed inclusion and exclusion criteria, but did not state whether it was blinded or whether there were any drop outs from the study. There was also a difference in the age of the males who participated in each group (39.7yrs versus 65.0yrs). Whether this was a confounding variable is not known as the statistical values for the demographics of the two treatment groups are not stated and this disparity is not explored. The results of this study demonstrated that after 4 months of treatment, statistically significant limb

volume reductions were achieved with oral HR or compression stockings (89.6mls ~ 9.0% and 230.0mls ~ 23.0% respectively), with the reduction achieved by the compression stockings being far greater. Subjective symptoms were not reported for either treatment regime and there was no follow up period.

Women with leg oedema related to chronic venous insufficiency were involved in Rehn et al's (1993) study which investigated Troxerutin 900mgs/day (n=6) and Oxerutin 900mgs/day (n=6) taken over 3 months. The study had a good explanation of the inclusion and exclusion criteria but did not state whether there were any drop outs or adverse events from the study. The reduction in leg volume is stated as that of the whole group combined; why this is the case (and why the two groups were not represented separately) is also not explained. The limb volume reduction of 17.7mls (~ 1.8%) in the overall group would be considered quite modest, although it was statistically significant. It was also stated that there were reductions in heaviness and tension and that these were greater in the group who took the Oxerutin (900mgs), however there are no accompanying statistical values, so the magnitude of the reduction and whether it was statistically significant (Oxerutin v's Troxerutin) is not known.

Thirty patients with leg oedema subsequent to chronic venous insufficiency were involved in Casley-Smith's (1988) trial which investigated Calcium Dobesilate 1,000mgs/day (n=15) in comparison to placebo (n=15) taken over a 6 week period. Although this study included both randomized allocation and double blinding techniques, there were no stated exclusions, with a brief statement of the inclusion criteria being 'patients with Widmer grade III (healed ulcers with truncular varicoses) leg oedema'. The results showed that the Calcium Dobesilate (1,000mgs) group experienced statistically significant reductions in limb volume (81mls ~ 8.1%) and reported leg heaviness, tension and pain. This was in comparison with the placebo

group, which had negligible change in limb volume (increase of 4mls ~ 0.4%) and no improvements in the aforementioned subjective symptoms. A follow up period was not included in this study, so it is not known whether the reductions from the Calcium Dobesilate would have been maintained.

Seven of the studies reviewed (Vanscheidt et al 2002; Nocker et al 1999; Diehm et al 1996; Rehn et al 1996; Nuemann & van den Broek 1995; Rehn et al 1993; Casley-Smith 1988) demonstrate the magnitude of limb volume reduction (which ranged from 10-95mls, ~ 1.0-9.5%) that can be achieved when oral pharmaceuticals are used in isolation. The studies by Vanscheidt et al (2002), Diehm et al (1996), Unkauf et al (1996) and Nuemann & van den Broek (1995) also showed the volume reductions that can be achieved when oral pharmaceuticals are combined with class II compression garments (43.3 - 230mls ~ 4.3 - 23.0%). All reviewed studies that recorded subjective symptoms such as tiredness, heaviness and tension displayed a reduction in these parameters. Three of the studies had follow up periods, with two of these studies (Rehn et al 1996; Unkauf et al 1996) demonstrating a small but continuing reduction in leg volume (21.1 - 35.4mls, ~ 2.1 - 3.5%), whilst one study (Vanscheidt et al 2002) demonstrated a slight increase in volume of 6.5mls (~ 0.7%).

Table 3.8b. Summary of Results of Oral Pharmaceuticals for Leg Oedema

Treatment Protocol	Change	Subjective Symptoms	Follow Up	Quality Score	Reference
<p><u>Tx</u>: 2 weeks of compression bandaging then SB-LOT (15mg Coumarin + 90mg Troxerutin), 2 tablets, 3 x day + compression stockings for first 4 weeks, stockings then stopped but tablets taken for further 12 weeks. (n = 114)</p> <p><u>Co</u>: 2 weeks of compression bandaging then placebo + compression stockings for first 4 weeks, stockings then stopped but tablets taken for further 12 weeks (n = 117)</p>	<p><u>Tx</u>:</p> <p>compressⁿ alone: ↓ 110mls ~ 11.0%</p> <p>compress + drug: ↓ 120mls ~ 12.0%</p> <p>drug alone: ↓ 95mls ~ 9.6%</p> <p><u>CO</u>:</p> <p>compressⁿ alone: ↓ 100mls ~ 10.0%</p> <p>compressⁿ + plac: ↓ 120mls ~ 12.0%</p> <p>drug alone: ↓ 85mls ~ 8.5%</p> <p>p values not stated</p>	<p><u>Both Grps</u>:</p> <p>↓ tiredness, heaviness, tension, aching, itching, tingling, burning</p> <p>Tx v's Co p < 0.05, except for aching</p>	<p><u>1 month</u>:</p> <p><u>Tx</u>:</p> <p>↑ 6.5mls, (± 12.2), ~ 0.6%</p> <p><u>CO</u>:</p> <p>↑ 36.7mls, (± 12.1), ~ 3.7%</p> <p>Tx v's CO p = 0.0402</p>	8	Vanscheidt et al (2002)
<p><u>Grp A</u>: HR 600mg (n = 6)</p> <p><u>Grp B</u>: HR 900mg (n = 6)</p> <p><u>Grp C</u>: HR 1,200mg (n = 6)</p>	<p>End of Regime:</p> <p><u>Grp A</u>: ↓ 13mls ~ 1.3%</p> <p><u>Grp B</u>: ↓ 14mls ~ 1.4%</p> <p><u>Grp C</u>: ↓ 18mls ~ 2.0%</p>	<p>All groups had statistically significant ↓ in subjective 'symptoms' in comparison to placebo p < 0.001</p>	<p><u>1 month</u>:</p> <p><u>Grp A</u>: ↓ 10mls ~ 1.0%</p> <p><u>Grp B</u>: ↓ 11mls ~ 1.1%</p> <p><u>Grp C</u>: ↓ 15mls ~ 1.5%</p>	6	Nocker et al (1999)

Table 3.8b. Summary of Results of Oral Pharmaceuticals for Leg Oedema (Cont.)

Treatment Protocol	Change	Subjective Symptoms	Follow Up	Quality Score	Reference
<p><u>Grp D:</u> HR 1,500mg (n = 6)</p> <p><u>Grp E:</u> Placebo - distilled water (n = 6)</p> <p>HR = O-(β-hydroxyethyl)-rutosides</p> <p>Duration: 1 x day for 3 months</p>	<p><u>Grp D:</u> ↓ 10mls ~ 1.0%</p> <p><u>Grp E:</u> ↑ 2mls ~ 0.2%</p>	<p>As above</p>	<p><u>Grp D:</u> ↓ 9mls ~ 1.0%</p> <p><u>Grp E:</u> ↑ 2mls ~ 0.2%</p>	<p>6</p>	<p>Nocker et al (1999)</p>
<p><u>Grp A:</u> 2 weeks of no treatment then 7 days of diuretic (25mg hydrochlorothiazide/50mg triamterence) 1 x day, then fitted with class II compression garment (n = 99)</p> <p><u>Grp B:</u> 2 weeks of no treatment then oral HCSE (Venostasin Retard, 50mg Aescin), 2 x day (n = 95)</p> <p><u>Grp C:</u> 2 weeks of no treatment then placebo, 1 capsule, 2 x day (n = 46)</p> <p>Duration: 12 weeks</p>	<p>End of Regime:</p> <p><u>Grp A:</u> ↓ 43.3mls (± 11.4) ~ 4.4%</p> <p><u>Grp B:</u> ↓ 46.7mls (± 8.2) ~ 4.7%</p> <p><u>Grp C:</u> ↑ 9.8 mls (± 15.0) ~ 1.0%</p> <p>HCSE v's Placebo p = 0.005</p> <p>Comprⁿ v's Placebo p = 0.002</p>	<p>Not reported</p>	<p>Nil</p>	<p>6</p>	<p>Diehm et al (1996)</p>

Table 3.8b. Summary of Results of Oral Pharmaceuticals for Leg Oedema (Cont.)

Treatment Protocol	Change	Subjective Symptoms	Follow Up	Quality Score	Reference
<p><u>Grp A:</u> 1 week of placebo then Oxerutin 1,000mg/day for 12 weeks (n =59)</p> <p><u>Grp B:</u> 1 week of placebo then Oxerutin 1,000mg/day for 4 weeks then 500mg/ day for 8 weeks (n = 37)</p> <p><u>Grp C:</u> 1 week of placebo then Horse Chestnut 600mg/day for 12 weeks (n = 62)</p>	<p>End of regime:</p> <p><u>Grp A:</u> ↓ 57.9mls (± 118.0) ~ 5.8%</p> <p><u>Grp B:</u> ↓ 40.2mls (± 101.4) ~ 4.1%</p> <p><u>Grp C:</u> ↓ 28.2mls (± 90.9) ~ 2.9%</p> <p>p values not stated</p>	<p><u>All Grps:</u></p> <p>↓ tiredness ↓ heaviness ↓ tension</p> <p><u>Grps A & B:</u></p> <p>↓ tingling</p> <p><u>Grp C:</u></p> <p>↑ tingling</p>	<p><u>6 weeks:</u></p> <p><u>Grp A:</u> ↓ 46.4mls (± 132.0) ~ 4.7%</p> <p><u>Grp B:</u> ↓ 21.1mls (± 112.5) ~ 2.2%</p> <p><u>Grp C:</u> ↓ 26.0mls (± 99.0) ~ 2.6%</p> <p>↓ tiredness/ heaviness/ tension ↓ tingling (Grps A & B) ↑ tingling (Grp C)</p>	6	Rehn et al (1996)
<p><u>Tx:</u> 1 week of diuretic then fitted with mid-length grade II compression garment then took 500mg Oxerutin 2 x day (n = 64)</p> <p><u>CO:</u> 1 week of diuretic then fitted with mid-length grade II compression garment then took placebo 2 x day (n = 56)</p> <p>Duration: 12 weeks</p>	<p>End of regime:</p> <p><u>Tx:</u> ↓ 63.9mls (± 77.8) ~ 6.5%</p> <p><u>CO:</u> ↓ 32.9mls (± 104.5) ~ 3.3%</p> <p>Tx v's Co p = 0.033</p>	<p>Both Groups:</p> <p>↓ tiredness ↓ heaviness ↓ tingling ↓ tension</p>	<p><u>3 weeks:</u></p> <p><u>Tx:</u> ↓ 35.4mls (± 75.7) ~ 3.6%</p> <p><u>CO:</u> ↑ 8.6mls (± 102.9) ~ 0.9%</p> <p>Tx v's CO p = 0.004</p> <p>Both Grps:</p> <p>↑ tiredness/ heaviness/ tension tingling</p>	7	Unkauf et al (1996)

Table 3.8b. Summary of Results of Oral Pharmaceuticals for Leg Oedema (Cont.)

Treatment Protocol	Change	Subjective Symptoms	Follow Up	Quality Score	Reference
			<p><u>6 weeks:</u> <u>Tx:</u> ↓ 32.2mls (± 76.8) ~ 3.3% ↑ tiredness/ heaviness - tension <u>CO:</u> ↓ 8.3mls (± 103.8) ~ 0.9% - tension/ tiredness/ heaviness ↑ tingling Tx v's CO p = 0.076</p>	7	Unkauf et al (1996)
<p><u>Grp A:</u> HR 500mg, 2 x day (n = 11) <u>Grp B:</u> Class II compression Stocking (n = 12) HR = O-(β-Hydroxy-Ethyl)-rutosides Duration: 4 months</p>	<p>End of regime: <u>Grp A:</u> ↓ 89.6ml s (± 30.8) ~ 9.0% p = 0.012 <u>Grp B:</u> ↓ 230.0mls (± 24.6) ~ 23.0% p < 0.001 Grp B v's A p = 0.005</p>	Not reported	Nil	4	Nuemann & van den Broek (1995)

Table 3.8b. Summary of Results of Oral Pharmaceuticals for Leg Oedema (Cont.)

Treatment Protocol	Change	Subjective Symptoms	Follow Up	Quality Score	Reference
<p><u>Grp A:</u> Oxerutin 900mg dissolved in 100mls of H₂O, taken after breakfast. (n = 6)</p> <p><u>Grp B:</u> Troxerutin 900mg dissolved in 100mls of H₂O, taken after breakfast. (n = 6)</p> <p>Duration: 3 months</p>	<p>End of regime: Entire population: ↓ 17.7mls (± 12.5) ~ 2.0% p = 0.005.</p>	<p>Both Grps: ↓ heaviness & tension Grp A > Grp B</p>	<p>Nil</p>	<p>5</p>	<p>Rehn et al (1993)</p>
<p><u>Tx:</u> Calcium Dobesilate 2 x 500mg, morning & evening (n = 15)</p> <p><u>CO:</u> Identical Placebo 2 x 500mg, morning & evening (n = 15)</p> <p>Duration: 6 weeks</p>	<p>End of regime: <u>Tx:</u> ↓ 81mls p < 0.001 ~ 8.1% <u>CO:</u> ↑ 4mls p = n.s. ~ 0.4% B/w Groups p < 0.01</p>	<p><u>Tx:</u> ↓ Heaviness, Tension & Pain p < 0.05 <u>CO:</u> No change</p>	<p>Nil</p>	<p>5</p>	<p>Casely- Smith (1988)</p>

Comparison Graphs of the Reviewed Conservative Therapies

For comparative purposes, control data gathered from clinical trials and Casley-Smith & Casley-Smith (1997) and the average percentage change achieved by each conservative therapy at end of trial for secondary arm lymphoedema and lower limb swelling (secondary leg lymphoedema and venous oedema) is represented in figure 3.1a and 3.1b. These two figures demonstrate what occurs when no treatment is instigated and the magnitude of reduction (average) achieved by the different conservative therapies.

Figure 3.1a. Average percentage change for each conservative regime at end of trial in secondary arm lymphoedema

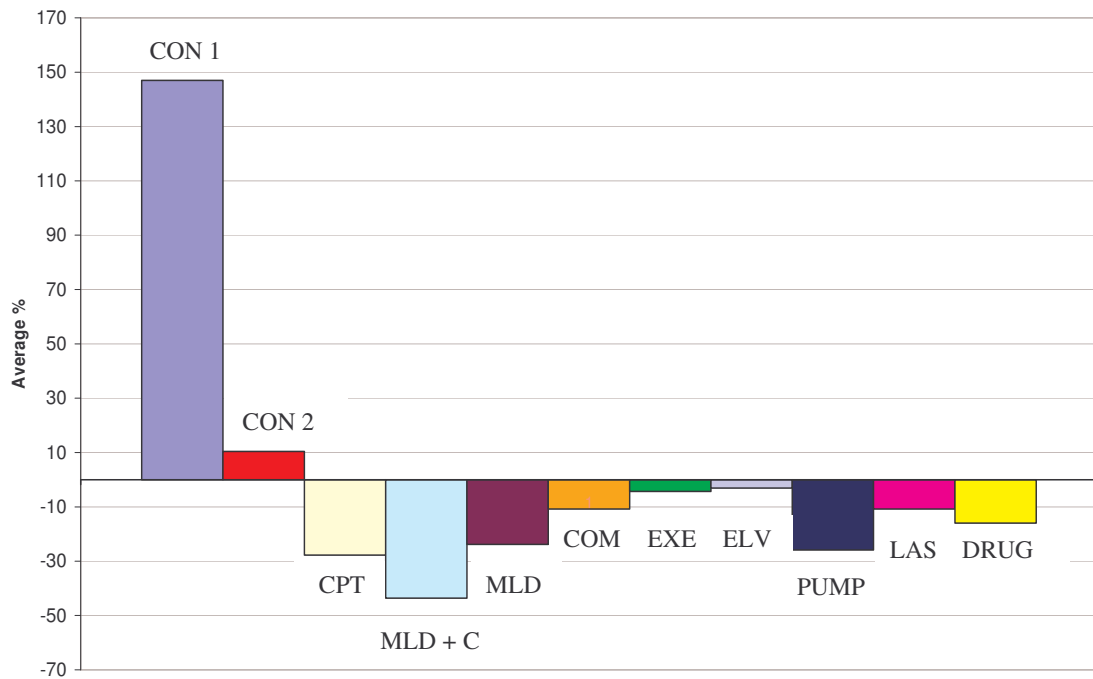

CON 1:	Control 1 (Casley-Smith data)	EXE:	Limb Exercise
CON 2:	Control 2 (placebo data)	ELV:	Elevation
CPT:	Complex Physical Therapy	PUMP:	Pneumatic Pump Therapy
MLD + C:	Manual Lymphatic Drainage + Compression	LAS:	Laser Therapy
MLD:	Manual Lymphatic Drainage only	DRUG:	Oral Pharmaceuticals
COM:	Compression (bandaging or garment)		

Figure 3.1b. Average percentage change for each conservative regime at end of trial in lower limb swelling

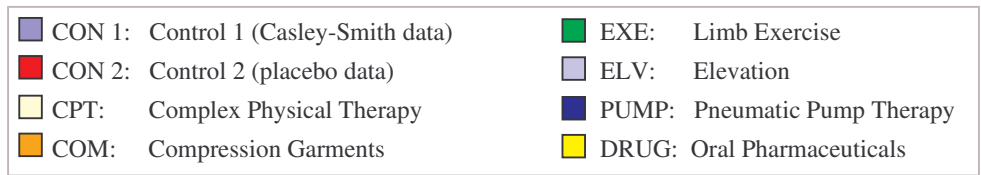
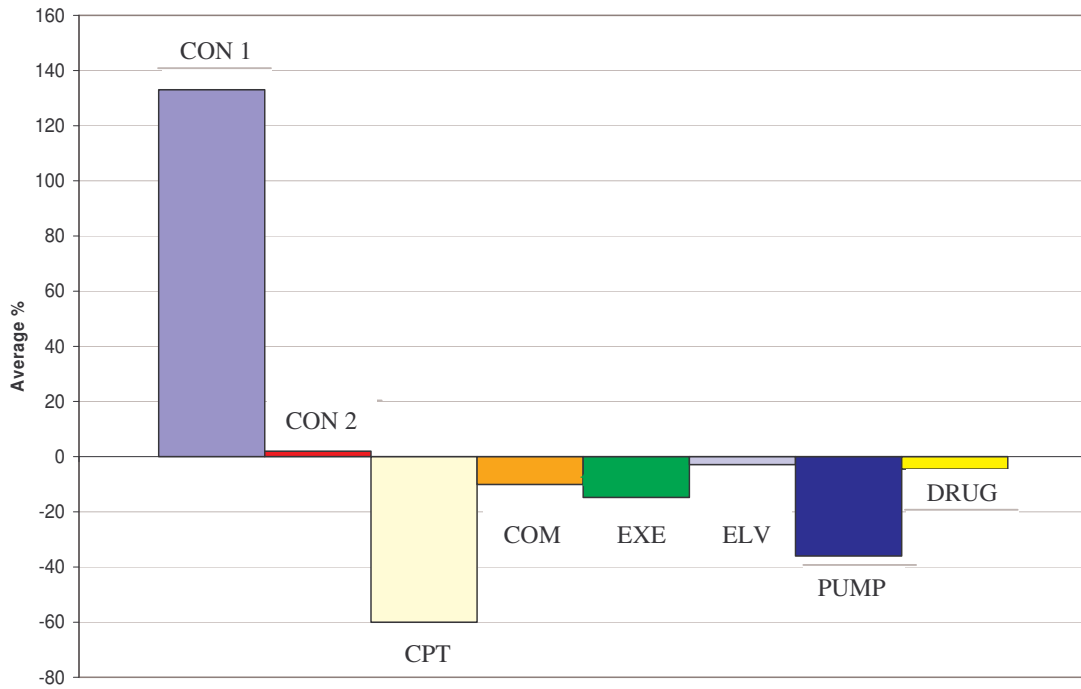

Discussion

All the reviewed CPT studies demonstrated that a reduction in terms of limb volume and/or percentage oedema could be achieved, with a few studies (Szolnocky et al 2002; Piller et al 1995; Carroll & Rose 1992) showing that this reduction was accompanied by an improvement in subjective symptoms. In this particular review, nearly all the results are from women with arm lymphoedema secondary to breast cancer treatment, with only one retrospective study (Heinrich et al 2004) that presented results on secondary leg lymphoedema. In those CPT studies that included a follow up period (Szuba et al 2000; Piller et al 1996; Bunce et al 1994; Casley-Smith & Casley-Smith 1992) the volume reduction from this form of therapy was either maintained or further reductions were reported.

Overall, the reviewed CPT studies showed that this form of therapy is beneficial for limb oedemas; however the initial phase must be quite intensive, with the patient having to attend an outpatients clinic on a daily basis or be a hospital inpatient for treatment. The maintenance phase of this therapy is also very reliant upon the patient complying with skincare, limb exercises and the wearing of a compression garment. The fact that all the studies that included a follow up measurement reported a maintenance or further reduction in limb volume indicates that at least some of the participants involved did indeed comply with this self maintenance regime.

The reviewed MLD studies showed reductions in limb volume, percentage oedema and subjective symptoms, with two studies (Piller et al 2004; Johanssen 1998) demonstrating these reductions after two weeks of treatment. One study (Anderson et al 2000) defied this trend, showing that wearing a compression sleeve and undertaking limb exercises was superior to MLD. Only one study (Williams et al 2002) involved self massage and showed that this can

also result in a small limb volume reduction but that it is probably best used as a form of maintenance therapy. Only three of the eight studies reviewed included a follow up period which showed that the initial reductions were sustained if participants undertook either self maintenance (Piller et al 1994) or additional treatment (Dubois 2004).

It would appear from the reviewed studies that manual lymphatic drainage in combination with compression (bandaging or garments) is superior to compression alone, both in relation to volume reduction and subjective symptoms (Korpon et al 2003; Johanssen et al 1999). Whether this is because more fluid is moved out of the limb and therefore the arm feels better or whether the patient perceives that more is being done for the arm (MLD + compression is more intensive and receives more professional input than compression alone) is uncertain. This form of therapy also makes the patient fairly dependant on the health professional administering the therapy, however patients and their partner/carer can be taught self massage and bandaging, which has been shown to be reasonably effective in terms of a reduction in limb volume and subjective symptoms (Piller et al 1995).

The reviewed compression studies demonstrated that small volume and percentage reductions and significant improvements in subjective symptoms were achieved when using compression alone, whether it was with short stretch bandaging (Johanssen et al 1999) or when wearing a compression garment (Korpon et al 2003). Reductions can also be observed to occur one week after wearing a garment and after 6 months (Swedborg 1983). A one year follow up undertaken by Andersen et al (2000) demonstrated that the initial percentage oedema reduction achieved from wearing a compression garment in combination with performing limb exercises was maintained.

Four reviewed studies (Diehm et al 1996; Ukauf et al 1996; Neumann & van den Broek 1995; Pierson et al 1983) involving participants with leg oedema of vascular origin showed that volume reductions from 43mls, 4.3% (Diehm et al 1996) to 230mls, 23.0% (Nuemann & van den Broek 1995) could be achieved with class II compression garments. The greatest leg volume reduction (230mls, 23.0%) was seen to occur after 4 months of compression wear (Nuemann & van den Broek 1995). Three of the studies (Ukauf et al 1996; Neumann & van den Broek 1995; Pierson et al 1983) did not include follow up periods so it is not known whether the volume reductions and compression garment compliance were maintained. One study (Diehm et al 1996) demonstrated that the limb volume and subjective symptom reductions achieved during the trial period were sustained at 2 months follow up.

Five studies were reviewed which involved women with secondary arm lymphoedema undertaking various exercise regimes (Moseley et al 2005; Box et al 2004; Buckley et al 2004; Johansson et al 2004; McKenzie & Kalda 2003). These regimes involved either; hydrotherapy, resistive training, exercise plus deep breathing or instructed self massage plus limb exercise, all performed over different time periods. All regimes demonstrated small reductions in limb volume and percentage oedema and consistent improvements in subjective symptoms and limb function. Most notably, none of these studies involving exercise resulted in a sustained increase in limb volume or percentage oedema, which is in concert with other literature that has explored this important issue (Turner et al 2004; Harris & Niesen-Vertommen 2000).

Passive exercise in combination with slight elevation was shown to be beneficial for both lymphoedema and vascular oedema of the legs, both in terms of volume reduction and subjective symptoms (Moseley et al 2004 & 2003). Similar (albeit smaller) volume reductions and subjective improvements were also observed in a pilot study of instructed massage and

sequential exercise which involved leg lymphoedema patients (Buckley et al 2004) and in a study by Ernst et al (1991), which involved a physical regime undertaken in water by those with leg oedema subsequent to varicose veins.

Four of the reviewed exercise studies (Moseley et al 2005; Box et al 2004; Moseley et al 2004 & 2003) demonstrated that the majority of volume reduction and subjective improvement derived from the exercise regimes were sustained over 3, 4 and 6 week follow up periods. Whether the sustained reductions were purely related to the exercise programs or the patient themselves being in a more positive frame of mind is impossible to know. Elevation of the limb was also shown to be beneficial in terms of percentage volume reduction in lymphatic and vascular oedema (Swedborg et al 1993; Xia et al 2004), but expecting a patient to elevate their limb for 4-5 hours on a daily basis is somewhat unrealistic.

Mixed results were observed in the reviewed studies involving pneumatic pump therapy, with Johanssen et al's (1998) study showing that wearing a class II compression garment was superior to pump therapy whilst Swedborg (1984) showed almost identical reductions with compression alone and in combination with pump therapy. Szuba et al (2002) achieved good reductions in limb volume and in percentage oedema when using pump therapy in combination with MLD and a compression garment. Certainly this makes sense, as the MLD would help to clear the areas adjacent to the affected limb helping drainage and the compression would help to maintain the reduction achieved. Administering MLD before pump therapy may also help to avoid the displacement of fluid into areas proximal and adjacent to where the pump is applied.

The graduated pumps showed an increased benefit in terms of volume and subjective symptom reduction when compared to uni or three compartmental chambers (Bergen et al 1998). Follow up periods demonstrated that some form of maintenance regime needed to be undertaken to maintain the reductions derived from the pump therapy, whether this was wearing a compression garment (Szuba et al 2002; Swedborg 1984) or continuing the pump therapy (Zelikovski 1980).

Three trials were reviewed which investigated the effects of low level laser therapy, including scanning laser applied to the whole affected arm (Piller & Thelander 1996, 1998) and hand held laser concentrated in the axilla of the affected arm (Carati et al 2003). Both studies demonstrated that laser therapy can reduce limb volume and associated subjective symptoms, with the reductions continuing at 3 to 6 months follow up. In fact, in both studies the volume reductions were greater at follow up, which may suggest that there are ongoing benefits of laser. Further studies to confirm this beneficial effect are certainly warranted.

A range of oral pharmaceuticals that are used in the treatment of secondary lymphoedema and oedema of vascular origin were reviewed. Three of these studies (Burgos et al 1999; Pecking et al 1997; Casley-Smith et al 1993) demonstrated the benefits of different oral pharmaceuticals for arm lymphoedema populations, whilst the study by Loprinzi et al (1999) demonstrated an arm volume increase and therefore worsening in those who took 400mgs/day of Coumarin over a 6 month period. In some of the reviewed studies the limb volume reduction and subjective improvements were not achieved by the oral pharmaceutical alone, but in combination with other therapies such as MLD (Cluzan et al 1996), diuretics (Unkauf et al 1996,) and class II compression garments (Vanscheidt et al 2002; Diehm et al 1996; Unkauf et al 1996). Diehm et al's (1996) study demonstrated that the volume reduction obtained by a diuretic in combination

with a class II compression garment were similar to that obtained from taking HSCE (Venostasin Retard 100mgs/Aescin 100mgs). However, in the clinical situation, compliance with taking an oral preparation is likely to be higher than wearing a compression garment, which patients often find difficult to apply and uncomfortable to wear.

Aside from studies involving oral pharmaceuticals, there is a paucity of rigorous, randomized, controlled trials in both lymphoedema and vascular oedema research that focus on conservative therapies. Certainly research in this area can be problematic in terms of justifying a prolonged control period in a chronic and progressive condition, recruiting participants who strictly fit the inclusion/exclusion criteria and blinding participants who essentially will know whether they are receiving active treatment or not. Problems also arose in the reporting of a number of research trials, with some studies not clearly defining the inclusion/exclusion criteria, explaining treatment allocation, outlining the exact treatment regime used and not stating the analysis undertaken or statistical values. Despite these encountered problems, this review has shown that conservative therapies can, in the most part, be beneficial for lymphoedema and oedema of vascular origin.

The therapies reviewed can be divided into intensive treatments administered by trained health professionals and maintenance therapies undertaken by the patient to help maintain the limb. As demonstrated by figures 3.1a and 3.1b, treatments that are predominantly administered by health professionals, such as complex physical therapy, manual lymphatic drainage (with and without compression), laser therapy and pneumatic pump therapy yielded the larger percentage reductions. Maintenance therapies (normally undertaken by the patient), such as wearing a compression garment, limb exercises, elevation and self massage yielded smaller percentage

reductions. However, this review has demonstrated that those therapies which would be categorized as 'self maintenance' are more beneficial than doing nothing at all for the limb.

This review also revealed the positive impact that treatment (and indeed no treatment - placebo) can have on subjective limb complaints. That is, no matter what the treatment regime (including sham treatment) there was consistently an improvement in subjective symptoms and quality of life. This trend demonstrates that doing 'something' equated to perceived benefits for the oedematous limb, which should be embraced and used to the advantage of both the clinician and patient. In fact, studies have shown that certain factors can accentuate the placebo effect; these include the patient's expectations (Benson & Friedman 1996), the therapist's belief in the treatment being offered (Kaptchuk 2002) and the patient-therapist relationship (Papakostas & Daras 2001). Being aware of these influences may help clinicians to initiate improvements in subjective symptoms, even if this is not necessarily followed by significant changes in objective parameters (such as limb volume).

Of course, the success of any form of therapy is reliant upon availability of qualified health professionals, cost constraints and, most importantly, patient compliance. The more intensive therapies such as CPT and MLD (\pm compression bandaging) have been shown to be beneficial in terms of percentage reduction (graphs 3.1a and 3.1b), but these 'optimal' therapies may not always be practical, accessible or economically viable for the patient. Therefore, it is also important to know that the more easier to implement and less costly self maintenance activities (including exercise) also have benefits, both in terms of modest volume reductions and improved subjective symptoms.

Appendix 3.1. Articles Excluded from the Systematic Review

COMPLEX PHYSICAL/DECONGESTIVE THERAPY

Bertelli G, Venturini M, Forno G, Macchiavello F, Dini D, 1991, 'Conservative treatment of postmastectomy lymphedema: A controlled, randomized trial', *Annals Oncol*, 2: 575 – 578
Reason for exclusion: data presented as circumference measurements, no measurements on limb volume.

Boris M, Weindorf S & Lasinski B, 1997, 'Persistence of lymphedema reduction after noninvasive complex lymphedema therapy', *Oncology*, 11(1): 99-109
Reason for exclusion: results presented are on primary and secondary lymphoedema limbs (mixed).

Clodius L & Piller NB, 1978, 'Conservative therapy for post mastectomy lymphedema', *Chir. Plastica (Berl)* 4: 193-202
Reason for exclusion: results presented only in circumference difference. No data on limb volume reduction or improvements in symptoms.

De Gody JMP, Bataigalia F & de Gody MFG, 2002, 'Preliminary technique for lymph drainage', *Lymphology*, 35(2): 91-3.
Reason for exclusion: mixed sample of primary and secondary lymphoedema, data presented as change in circumference, no data presented on change in limb volume.

Denis B, 1995, 'Acquired lymphedema: a review of nine women's responses to intervention', *Amer J Occup Ther*, 47: 891-99
Reason for exclusion: qualitative review of patient case notes, no limb volume data.

Ko DS, Lerner R, Klose G & Cosimi AB, 1998, 'Effective treatment of lymphedema of the extremities', *Arch Surg*, 133: 452-458
Reason for exclusion: results presented are on primary and secondary limbs (mixed).

Matthews K & Smith J, 1996, 'Effectiveness of modified complex physical therapy for lymphoedema, treatment', *Australian J Physiotherapy*, 42(4): 323-8
Reason for exclusion: data presented as circumference measurements, no data on leg volume.

Nieto S, 1994, 'Follow up of limb lymphedema patients treated by Földi method', *Progress in Lymphology XIV Proceedings of the 14th International Congress of Lymphology*, Washington DC, September 20-26, 1993. *Lymphology* 27: 585-88
Reason for exclusion: data presented as change in circumference, no data on arm volume change.

Petlund F, 'The complex decongesting physiotherapy in lymphoedema', *Progress in Lymphology, XII Proceedings of the XIIth International Congress of Lymphology*, Tokyo, Japan, 27th Aug – 2nd Sep 1989. Elsevier Science Publishers (1990), New York: 91-94
Reason for exclusion: results presented are on primary, secondary and lipoedema limbs (mixed).

Todd JE, 1999, 'A study of lymphoedema patients over their first six months of treatment', *Physiotherapy*, 85(2): 65-76

Reason for exclusion: results presented are on primary, secondary, venous and lipoedema limbs (mixed).

MANUAL LYMPHATIC DRAINAGE

Fiaschi E, Francesconi G, Fiumicelli S, Nicolini A, Camici M, 1998, 'Manual lymphatic drainage for chronic post-mastectomy lymphoedema treatment', *Panminerva Medica*, 40(1): 48-50

Reason for exclusion: data presented in circumference reduction, no data on volume reduction.

Kirshbaum M, 1996, 'Using massage in the relief of lymphoedema', *Profess Nurse*, 11(4): 230-2

Reason for exclusion: data presented as semi-structured interviews, no data on volume reduction.

Radaković N, Popović-Petrović S, Vranješ N & Petrović T A ,1998, 'Comparative pilot study of the treatment of arm lymphedema by manual drainage and sequential external pneumatic compression (SEPC) after mastectomy', *Arch Oncol*, 6(4): 177-8

Reason for exclusion: data presented as change in circumference, no data on limb volume change.

COMPRESSION

Arcelus JI, Caprini JA, Sehgal LR & Reyna JJ, Nov 2001, 'Home use of impulse compression of the foot and compression stockings in the treatment of chronic venous insufficiency', *J Vasc Surg*, 34 (5): 805 – 811

Reason for exclusion: results presented as changes in venous volume, venous filling index, ejection fraction and residual volume fraction. No data on limb volume reduction.

Badger CM, Peacock JL & Mortimer PS, Jun 2000, 'A randomized, controlled, parallel-group clinical trial comparing multilayer bandaging followed by hosiery versus hosiery alone in the treatment of patients with lymphedema of the limb', *Cancer*, 88 (12): 2832 - 2837

Reason for exclusion: patients with unilateral upper or lower limb lymphoedema were recruited irrespective of cause (ie: sample not all secondary lymphoedema sufferers).

Bergen JJ & Sparks SR, Mar 2000, 'Non-elastic compression: an alternative in management of chronic venous insufficiency', *J WOCN*, 27(2): 83-89

Reason for exclusion: general review on elastic versus non-elastic bandaging, not a clinical trial.

Bertelli G, Venturini M, Forno G, Macchiavello F, Dini D, 1992, 'An analysis of prognostic factors in response to conservative treatment of postmastectomy lymphedema', *Surg, Gyn & Obstetrics*, 175(5): 455-460

Reason for exclusion: data presented as circumference measurements, no measurements on limb volume.

Haslett ML, Aitken MJ, 2002, 'Evaluating the effectiveness of a compression sleeve in managing secondary lymphoedema', *J Wound Care*, 11(10): 401-4

Reason for exclusion: not a clinical trial, case study involving 2 patients only.

Horner J, Fernandes E, Nicolaidis AN, 1980, 'Value of graduated compression stockings in deep venous insufficiency', *Br Med J*, 280:920

Reason for exclusion: measured venous pressure, no data on volume change or subjective symptoms.

Jungbeck C, Thulin I, Darenheim C & Norgren L, 1997, 'Graduated compression treatment in patients with chronic venous insufficiency: A study comparing low and medium grade compression stockings' *Phlebology*, 12: 142-145

Reason for exclusion: data presented as changes in foot volumetry only, no data on whole leg volume.

Motykie GD, Caprini JA, Arcelus JJ, Reyna JJ, Overom E & Mokhtee D, 1999, 'Evaluation of therapeutic compression stockings in the treatment of chronic venous insufficiency', *Dermatol Surg*, 25: 116-120

Reason for exclusion: Only 52% of the sample (n = 112) had oedema as determined by venous duplex scanning and CEAP classification. No data presented on limb volume reduction

Pappas CJ & O'Donnell TF Jr., 1992, 'Long-term results of compression treatment for lymphedema', *J Vasc Surg*, 16(4): 555-62

Reason for exclusion: Data presented as circumference measurements, no data on limb volume.

Raines JK, O'Donnell TF, Kalisher L et al, 1977, 'Selection of patients with lymphedema for compression therapy', *Amer J Surg*, 153: 450-57

Reason for exclusion: No data presented on limb volume.

Rose K, Taylore H & Twycross R, 1993, 'Volume reduction of arm lymphoedema', *Nurs Standard*, 7(35): 29-32.

Reason for exclusion: Sample includes those with regional node and skin metastases.

Spence RK & Cahall E, Nov 1996, 'Inelastic versus elastic leg compression in chronic venous insufficiency: a comparison of limb size and venous hemodynamics', *J Vasc Surg*, 34(5): 783-787

Reason for exclusion: predominantly focuses on venous hemodynamics. No data on limb volume reduction or improvements in symptoms.

Williams AF & Williams AE, Jul 1999, 'Putting the pressure on': a study of compression sleeves used in breast cancer-related lymphoedema', *J Tissue Viability*, 9(3):89-94

Reason for exclusion: investigated pressures of compression garments at the skin interface, no data on volume change.

Yasuhara H, Shigematsu H & Muto TA, 1996, '15 study of the advantages of elastic stockings for leg lymphedema', *Int Angiology*, (3): 272 – 277

Reason for exclusion: data presented as percentage of patients who improved or deteriorated whilst wearing elastic stockings, no measurements on actual limb volume.

EXERCISE

Turner J, Hayes S & Reul-Hirche H, 2004, 'Improving the physical status and quality of life of women treated for breast cancer: A pilot study of a structured exercise intervention', *J Surg Oncol*, 86: 141-46

Reason for exclusion: data presented in sum of circumference of the whole arm but no data on volume reduction. Inadequate sample size (n = 2 within n= 10).

PNEUMATIC PUMPS

Allenby F, Pflug JJ & Calan JS, 1973, 'The use of pneumatic compression in the swollen limb', *J Physiology*, 231: 65

Reason for exclusion: conference proceedings that don't mention the method of the trial or data on limb volume reduction or improvements in symptoms.

Bergan J.J., Sparks S., Angle N, 1998, 'A comparison of compression pumps in the treatment of lymphedema', *Vasc Surg*, (32):455-462.

Reason for exclusion: mixed sample of primary & secondary lymphoedema

Berlin E, Gjöres JE, Ivarsson C, Palmqvist I, Thagg G & Thulesius O, Dec 1999, 'Postmastectomy lymphoedema', Treatment and a five-year follow-up study', *Int Angiology*, 18(4): 294-98

Reason for exclusion: poor reporting and lack of stats. analysis makes conclusions difficult.

Dini D, Del Mastro L, Gozza A, Lionetto R, Garrone O, Forno G, Vidili G, Bertelli G & Venturini M, 1998, 'The role of pneumatic compression in the treatment of post-mastectomy lymphedema trial. A randomized phase III study', *Annals Oncol*, 9: 187-190

Reason for exclusion: results presented as a difference in circumference measurements between limbs at & points expressed as delta value. No data on limb volume reduction or improvements in symptoms.

Gan JL, Chang TS & Liu W, 1994, 'The circulatory pneumatic apparatus for lymphedema of the limb', *Euro J Plastic Surg*, 17: 169-172

Reason for exclusion: results presented are on primary, secondary and filariasis lymphoedema limbs (mixed).

Ginsberg JS, Magier D, Mackinnon B, Gent M, Hirsh J, 1999, 'Intermittent compression units for severe post-phlebotic syndrome: a randomized crossover study', *CMAJ*, 160: 1303-1306

Reason for exclusion: no data on severity of limb swelling /degree of oedema. Results presented as symptom scores, no data on limb volume reduction

Grieverson S, 2003, 'Intermittent pneumatic compression pump settings for the optimum reduction of oedema', *J Tissue Viability*, 13(3): 98-110

Reason for exclusion: reduction expressed in cms – no data on volume reduction.

Hopkins E, 1996, 'Sequential compression to treat lymphoedema', *Prof Nurse*, 11(6): 397-98

Reason for exclusion: not a clinical trial, case study.

Kim-Sing C & Basco V, 1987, 'Postmastectomy lymphedema treated with the Wright Linear Pump', *Canadian J Surg*, 30(5): 368 – 370.

Reason for exclusion: data represented as changes in circumference, no data on limb volume.

Klein MJ & Alexander MA, Wright JM, Redmond Ck, Le Gasse AA, 1988, 'Treatment of adult lower extremity lymphedema with the Wright linear pump: statistical analysis of a clinical trial', *Arch Phys & Med Rehab*, 69: 202-206

Reason for exclusion: mixed sample of primary and secondary lymphoedema.

Masman AR & Conolly WB, 1976, 'Intermittent pressure in the management of post-traumatic oedema and lymphoedema. The rationale and description of a new method', *Med J Australia*, 1(4): 87-89

Reason for exclusion: data presented as circumference measurements, no data on leg volume.

Partsch H, Mostbeck A & Leitner G, 1981, 'Experimental investigations on the effect of pressure wave massage apparatus (Lympha-press) in lymphedema', *Z Lymphology*, 5(1): 35-9

Reason for exclusion: sample group not known, only states that the apparatus was used on a number of patients with arm and leg lymphoedema – not known whether they were primary or secondary lymphoedema.

Richmand DM, O'Donnell TF & Zelikovski A, 1985, 'Sequential pneumatic compression for lymphoedema', *Arch Surg*, 20:116-119

Reason for exclusion: Sample is a mixture of primary and secondary lymphoedema. Data presented as circumference, no measurements on limb volume.

Viejo MAG, Huerta JC, Navea ML, Marticorena TE, Arzoz AR & Paos MA, 1998, 'Efficiency of treatment of lymphedema of the upper limb by multicompartiment sequential pneumatic compression therapy', Translated from the original, *Rehabilitation (Madr)*, 32:234-250.

Reason for exclusion: sample group included females and one male that had breast cancer surgery.

Yamazaki Z, Idezuki Y, Nemoto T & Togawa T, 1988, 'Clinical experience using pneumatic massage therapy for edematous limbs over the last 10 years', *Angiology*, 39(2): 154-163

Reason for exclusion: data presented as circumference measurements, no measurements on limb volume.

Yamazaki Z, Baba N, Idezuki Y, Nemoto T, Toyoshima K & Togawa T, 1990, 'Long-term pneumatic massage therapy for edematous limbs using pneumatic undulatory massage device (Hadomer)', *Progress in Lymphology – XII Proceedings of the XIIth International Congress of Lymphology*, Tokyo, Kyoto, Japan 27 August – 2 September 1989. Nishi M, Uchino S & Yabuki S, (Eds), Elsevier Science Publishers, The Netherlands: 435-436

Reason for exclusion: Unclear as to whether sample is a mix of primary or secondary lymphoedema. Results presented as percentage of those who improved, no data on limb volume.

Zanolla R, Monzeglio C, Balzarini A & Martino G, 1984, 'Evaluation of the results of three different methods of postmastectomy lymphedema treatments', *J Surg Oncol*, 26(3): 210-13

Reason for exclusion: data presented as circumference reduction, no data on volume reduction.

Zelikovski A, Haddad M & Reiss R, 1986, 'The "Lympha-Press" intermittent sequential pneumatic device for the treatment of lymphoedema: five years of clinical experience', *J Cardiovasc Surg*, 27(3): 288-290

Reason for exclusion: inadequate data on actual sample ie: age, cause of condition, duration of the condition etc.

Zelikovski A, Manoach M, Giler S & Urca I, 1980, 'Lymph Press. A new pneumatic device for the treatment of lymphedema of the limbs', *Lymphology*, 13(2): 68-73

Reason for exclusion: results presented are on primary and secondary lymphoedema limbs (mixed).

ORAL PREPARATIONS

Arceo A, Berber A & Trevino C, Sep/Oct 2002, 'Clinical evaluation of the efficacy and safety of Calcium Dobesilate in patients with chronic venous insufficiency of the lower limbs', *Angiology*, 53 (5): 539 – 543

Reason for exclusion: No data on limb volume reduction.

Beltramino R, Penenory A & Buceta AM, Dec 1999, 'An open-label, randomized multicentre study comparing the efficacy and safety of CYCLO 3[®] FORT versus hydroxyethyl rutoside in chronic venous insufficiency', *Int Angiology*, 18(4): 337 - 342

Reason for exclusion: No data on limb volume reduction.

Bergqvist D, Hallböök T, Lindblad B & Lindhagen A, 1981, 'A double-blind trial of 0-(β -Hydroxyethyl)-Rutosides in patients with chronic venous insufficiency', *VASA*, 10(3): 253-260

Reason for exclusion: data presented as changes in venous dynamics and circum feral change, no data on volume reduction.

Casley-Smith JR & Casley Smith JR, 'Lymphoedema therapy in Australia: Complex physical therapy and benzopyrones, on over 600 limbs' Presented at XIV International Congress of Lymphology, Washington, 20-26 September 1993.

Reason for exclusion: results presented are on primary and secondary lymphoedema limbs (mixed) and children.

Chang TS, Gan JL, Fu KD & Huang WY, Sep 1996, 'The use of 5,6 benzo-[alphs]-pyrone (coumarin) and heating by microwaves in the treatment of chronic lymphedema of the legs', *Lymphology*, 29(3): 106-111

Reason for exclusion: results presented are on primary, secondary and filariasis lymphoedema limbs (mixed).

Cloarec M, Clement R & Griton P, 1996, 'A double-blind clinical trial of Hydroxy-ethyl-rutosides in the treatment of the symptoms and signs of chronic venous insufficiency', *Phlebology*, 11: 76-82

Reason for exclusion: results presented only in circumference difference. No data on limb volume reduction.

Clodius L & Piller NB, 1982, 'The conservative treatment of post mastectomy lymphoedema patients with coumarin results in a marked continuous reduction in arm swelling', *Advances in Lymphology – Proceedings of the VIIIth International Congress of Lymphology, Montreal, September 20 – 25 1981*. Bartos V & Davidson JW, (Eds), Avicenum (Czechoslovakia): 471-474

Reason for exclusion: data presented as reduction in limb circumference, no data on limb volume reduction.

Cluzan RV, Pecking AP, Mathiex-Fortunet H, Leger Picherit E, Jun 2004, 'Efficacy of BN165 (Ginkor Fort) in breast cancer related upper limb lymphedema: a preliminary study', *Lymphology*, 37(2):47-52.

Reason for exclusion: results presented as lymphoscintigraphic kinetic parameter changes. No data on limb volume changes.

Cluzan R & Pecking A, 1990, 'Benzopyrone (Lysedem) double blind crossing over study in patients with secondary upper limb edemas', *Progress in Lymphology – XII Proceedings of the XIIth International Congress of Lymphology, Tokyo, Kyoto, Japan 27 August – 2 September 1989*. Nishi M, Uchino S & Yabuki S, (Eds), Elsevier Science Publishers, The Netherlands: 453-454

Reason for exclusion: No data on actual limb volume reduction.

Danielsson G, Jungbeck C, Peterson K, Norgren L A, 2002, 'Randomised controlled trial of micronised purified flavonoid fraction v's placebo in patients with chronic venous disease', *Eur J Vasc & Endovasc Surg* 23(1): 73-6.

Reason for exclusion: data presented as changes in hemodynamics, and foot volume (only) – no data on whole limb reduction.

Desprez-Curley JP, Cluzan R & Peccking A, 1985, 'Benzopyrones and post-mastectomy lymphedemas. Double-blind trial placebo versus sustained release coumarin with trioxyethylrutin (TER)', *Progress in Lymphology X – Proceedings of the Xth International Congress of Lymphology, Adelaide, Australia, 26 August – 2 September 1985*. Casley-Smith JR & Piller NB, (Eds), Solar Print, Australia: 203 – 205

Reason for exclusion: data presented as reduction in limb circumference, no data on limb volume reduction.

Diebschlag W, Nocker W, Lehmacher W & Rehn D, 1994, 'A clinical comparison of tow doses of O-(β -Hydroxethyl)-rutosides (Oxerutins) in patients with chronic venous insufficiency', *J Pharm. Med*, 4: 7-14

Reason for exclusion: data presented as difference in volume between the two legs, no data on actual volume change in the 'pathological' leg.

Dominguez C, Brautigam I, Gonzalez E, Gonzalez JA, Nazco J, Valiente R & Boada J, 1992, 'Therapeutic effects of hidrosmin on chronic insufficiency of the lower limbs', *Curr Med Research & Opinion*, 12(10): 623-630

Reason for exclusion: results presented as difference in limb assessed via photography, no data on limb volume reduction.

Gilly R, Pillion G & Frileux C, 1994, 'Evaluation of a new venoactive micronized flavanoid fraction (S 5682) in symptomatic disturbances of the venolymphatic circulation of the lower limb: A double-blind, placebo-controlled study', *Phlebology*, 9: 67-70

Reason for exclusion: results presented as circumference measurements – no data on volume reduction.

Guillot B, Guilhou JJ, de Champvallins M, Mallet C, Moccatti D, Pointel JP, 1989, 'A long treatment with venotropic drug. Results on efficacy and safety of Daflon 500mg in chronic venous insufficiency', *Int Angiology*, 8 (4 – suppl): 67-71

Reason for exclusion: data represented as circumference measurements, no data on volume reduction.

Incandela L, Belcaro G, Renton S, DeSanctis MT, Cesarone MR, Bavera P, Ippolito E, Bucci M, Griffin M, Geroulakos G, Dugall M, Golden G, Acerbi G, 2002, 'HR (Paroven, Venoruton, O-(beta-hydroxyethyl)-rutosides) in venous hypertensive microangiopathy: a prospective, placebo-controlled, randomized trial', *J Cardiovasc Pharma & Therapeutics*, 7(suppl 1): S7-10

Reason for exclusion: data presented as reduction in micro-filtration and reflux, no data on volume reduction.

Koch R, 2002, 'Comparative study of Venostasin and Pycnogenol in chronic venous insufficiency', *Phytotherapy Res*, 16: S1-S5

Reason for exclusion: results presented in circumference difference. No data on limb volume reduction.

MacLennan WJ, Wilson J, Rattenhuber V, Dikland WJ, Vanderdonckt J, Mariau M, 1994, 'Hydroxyethylrutosides in elderly patients with chronic venous insufficiency: its efficacy and tolerability', *Gerontology*, 40(1):45-52

Reason for exclusion: data presented in circumference measurements, no data on leg volume

Mortimer PS, Badger C, Clarke I & Pallett J, 1995, 'A double-blind, randomized, parallel-group, placebo-controlled trial of O-(β -Hydroxyethyl)-rutosides in chronic arm oedema resulting from breast cancer treatment', *Phlebology*, 10: 51-55

Reason for exclusion: patients with active carcinoma were included in the trial.

Paul V & Lange P, 1983, 'Benzaron bei Bein-ödemen infolge chronisch-venöser Insuffizienz', *Therapeutische Mitteilug*, 125 (16): 343-344

Reason for exclusion: data presented on circumference measurements – no data on volume reduction.

Pecking AP, Floiras JL, Rambert P, Boudinet A, Lasry S, Garbay JR, Feverier B, Wargon C, Pillion G & Rouesse J, 1996, 'Efficacy of Daflon 500mg[®] in the treatment of secondary upper limb lymphedema. Progress in Lymphology XV Proceedings of the 15th International Congress of Lymphology, Recife and Sao Paulo, Brazil, September 25-30, 1995. Mayall RC, Andrade MFC, Witte MH & Witte CL, (Eds), *Lymphology* 29 (suppl): 262-265

Reason for exclusion: states that there was a reduction in arm volume but figures not given.

Piller NB & Clodius L, 1982, 'Clinical results of the effectiveness of venalot in 103 post mastectomy lymphoedema patients', *Advances in Lymphology – Proceedings of the VIIIth International Congress of Lymphology, Montreal, September 20 – 25 1981*. Bartos V & Davidson JW, (Eds), Avicenum (Czechoslovakia): 475-479

Reason for exclusion: data presented as reduction in limb circumference, no data on limb volume reduction.

Piller NB, Morgan RG & Casley-Smith JR, 1985, "Paroven"[®] (Venoruton[®]) and chronic lymphoedema', *Progress in Lymphology X – Proceedings of the Xth International Congress of Lymphology, Adelaide, Australia, 26 August – 2 September 1985*. Casley-Smith JR & Piller NB, (Eds), Solar Print, Australia: 200-202

Reason for exclusion: results presented are a combination of primary and secondary lymphoedema participants.

Pulvertaft TB, Dec 1997, 'Paroven in the treatment of chronic venous insufficiency', *The Practitioner*, 223: 838-841

Reason for exclusion: data presented as change in subjective symptom scores, no data on reduction in limb volume.

Rish L & Rodriguez JC, 1972, 'Effect of O-(β -Hydroxyethyl)-Rutosides on oedema in chronic venous insufficiency of the lower limb', *Angiologica*, 9:62-66

Reason for exclusion: data presented as circumference change, no data on limb volume change.

Taylor HM, Rose KE & Twycross RG, 1993, 'A double-blind clinical trial of Hydroxyethylrutosides in obstructive arm lymphoedema', *Phlebology*, Suppl 1: 22-28

Reason for exclusion: sample includes 1 male who developed lymphoedema post scc of hand and axillary node clearance.

Ting A, Cheng S, Wu L, Cheung G, Nov/Dec 2001, 'Clinical and hemodynamic outcomes in patients with chronic venous insufficiency after oral micronized flavonoid therapy', *Vasc Surg*, 35 (6): 443-447

Reason for exclusion: recruited patients with limbs graded 1-4 on CEAP (oedema starts at level 3), data presented in circumference difference but no data on volume reduction.

Van Cauwenberge H, 1978, 'Double blind study of the efficacy of O-(β -hydroxyethyl)-rutosides in the treatment of venous conditions', *Médecine et Hygiène*, 36: 4175-4177.

Reason for exclusion: results only on reduction in symptoms, no data on volume reduction.

Widmer L, Biland L, Barras JP, 1990, 'Doxium[®] 500 in chronic venous insufficiency: a double-blind placebo controlled multicentre study', *Int Angiology*, 9(2): 105 – 110.

Reason for exclusion: results presented as circumference measurements at two points – no data on volume reduction

Appendix 3.2a. Quality Assessment Tool for Randomized Trials.

1. Was the inclusion and exclusion criteria clearly stated?
 Yes (1) No (0)

2. Was the randomization technique stated and explained?
 Yes, stated and explained (2) Yes, stated only (1) No (0)

3. Was it stated whether there were any adverse effects related to the instigated treatment(s)?
 Yes (1) No (0)

4. Was the study double-blinded and was the technique of blinding stated and explained?
 Yes, stated and explained (2) Yes, stated only (1) No (0)

5. Was the withdrawal and drop out rate stated and an explanation given?
 Yes (1) No (0)

6. Was the type of statistical analysis stated and appropriate?
 Yes (1) No (0)

7. Were the sample groups comparable in terms of descriptive data?
 Yes (1) No (0)

8. Was the study single-blinded and was the technique of blinding stated?
 Yes (1) No (0) N/A

Total Score: /10

Appendix 3.2b. Quality Assessment Tool for Non-Randomized Trials.

1. Was the sample group adequately described?
 Yes (1) No (0)

2. Was the inclusion and exclusion criteria clearly stated?
 Yes (1) No (0)

3. Was the rationale for the study clearly stated?
 Yes (1) No (0)

4. Was the type of treatment allocation stated and explained?
 Yes (1) No (0)

5. Was the type(s) of care/treatment stated and explained?
 Yes (1) No (0)

6. Was it stated whether there were any adverse effects related to the instigated treatment(s)?
 Yes (1) No (0)

7. Was the withdrawal and drop out rate stated and an explanation given?
 Yes (1) No (0)

8. Was the type of statistical analysis stated and appropriate?
 Yes (1) No (0)

Total Score: /8

Appendix 3.3a. Quality Ratings of Randomised Trials

	Q1. Inclus ⁿ /Exlus ⁿ	Q2. randomisat ⁿ	Q3. adverse effs	Q4. double blind	Q5. drop outs	Q6. analysis	Q7. comparable	Q8. single blind	Total
CPT									
Szolnoky et al (2002)	1	1	0	0	0	1	1	0	4
Swedborg (1980)	1	1	0	0	1	0	1	0	4
MLD									
Korpon et al (2003)	0	1	1	0	0	0	0	0	2
Williams et al (2002)	1	1	0	0	1	1	1	0	5
Anderson et al (2000)	1	1	0	0	1	1	1	0	5
Johansson et al (1999)	1	2	0	0	1	1	1	0	6
Johansson et al (1998)	1	1	0	0	1	1	1	0	5
Compression									
McNeely et al (2004)	1	2	1	0	1	1	1	1	8
Korpon et al (2003)	0	1	1	0	0	0	0	0	2
Andersen et al (2000)	1	1	0	0	1	1	1	0	5
Johansson et al (1999)	1	2	0	0	1	1	1	0	6
Diehm et al (1996)	1	1	1	0	0	1	1	1	6

Appendix 3.3a. Quality Ratings of Randomised Trials (Cont.)

	Q1. Inclus ⁿ /Exlus ⁿ	Q2. randomisat ⁿ	Q3. adverse effs	Q4. double blind	Q5. drop outs	Q6. analysis	Q7. comparable	Q8. single blind	Total
Compression									
Unkauf et al (1996)	1	1	0	0	1	1	1	0	5
Hornsby (1995)	0	1	0	0	0	0	0	0	1
Exercise									
Moseley et al (2005)	1	0	1	0	1	1	1	0	5
Box et al (2004)	0	1	0	0	0	1	1	1	4
McKenzie & Kalda (2003)	1	1	1	0	0	1	1	0	5
Ernst et al (1991)	1	1	0	0	0	1	1	1	5
Laser Therapy									
Carati et al (2003)	1	2	0	2	1	1	1	N/A	8
Pump Therapy									
Szuba et al (2002)	1	1	1	0	1	1	1	0	5
Bergan et al (1998)	0	1	0	0	1	1	1	0	5
Johansson et al (1998)	1	1	0	0	1	1	1	0	5

Appendix 3.3a. Quality Ratings of Randomised Trials (Cont.)

	Q1.	Q2.	Q3.	Q4.	Q5.	Q6.	Q7.	Q8.	Total
	Inclusⁿ/Exlusⁿ	randomisatⁿ	adverse effs	double blind	drop outs	analysi	comparable	single blind	
Oral Preparations									
Vanscheidt et al (2002)	1	2	1	1	1	1	1	0	8
Burgos et al (1999)	1	1	1	1	1	1	1	0	7
Loprinzi et al (1999)	1	1	1	1	1	1	1	0	7
Nocker et al (1999)	1	1	1	1	0	1	1	0	6
Pecking et al (1997)	0	1	1	1	0	1	0	0	4
Cluzan et al (1996)	1	1	1	1	1	1	1	0	7
Diehm et al (1996)	1	1	1	0	0	1	1	1	6
Rehn et al (1996)	1	1	1	1	1	0	1	0	6
Unkauf et al (1996)	1	1	1	1	1	1	1	0	7
Nuemann & van den Broek (1995)	1	1	0	0	0	1	1	0	4
Casley-Smith et al (1993)	1	2	1	1	1	1	1	0	8
Rehn et al (1993)	1	1	0	1	0	1	1	0	5
Casley-Smith (1988)	0	1	1	1	0	1	1	0	6

Appendix 3.3b. Quality Ratings of Non-Randomised Trials

	Q1. sample	Q2. Inclus ⁿ /Exclus ⁿ	Q3. rationale	Q4. allocation	Q5. regime	Q6. adverse effs	Q7. drop outs	Q8. analysis	Total
CPT									
Hinrichs et al (2004)	1	0	1	0	0	1	0	1	4
Szuba et al (2002)	1	0	1	0	1	0	0	1	4
Wozniewski et al (2001)	1	1	1	0	1	0	0	1	5
Boris et al (1994)	1	0	1	0	1	0	0	1	4
Bunce et al (1994)	0	1	1	0	1	0	0	1	4
Piller et al (1994)	1	1	1	0	1	1	0	0	5
Caroll & Rose (1992)	1	0	1	0	0	0	0	1	3
Casely Smith & Casley Smith (1992)	1	0	1	0	0	0	0	1	3
MLD									
Dubois (2004)	1	0	0	0	1	0	0	0	2
Piller et al (1994)	0	1	1	1	1	0	0	1	5
Compression									
Ang et al (2002)	1	1	1	1	1	0	0	1	6
Johansson et al (1998)	1	1	0	0	1	1	1	0	5
Swedborg (1984)	1	1	1	1	1	0	0	0	5
Pierson et al (1983)	1	0	1	1	1	0	0	1	5

Appendix 3.3b. Quality Ratings of Non-Randomised Trials (Cont.)

	Q1. sample	Q2. Inclus ⁿ /Exclus ⁿ	Q3. rationale	Q4. allocation	Q5. regime	Q6. adverse effs	Q7. drop outs	Q8. analysis	Total
Exercise									
Buckley et al (2004)	1	0	1	0	1	0	0	1	4
Moseley et al (2004)	1	1	1	0	1	1	0	1	6
Johansson et al (2004)	1	0	1	1	1	0	0	0	4
Moseley et al (2003)	1	1	1	0	1	1	0	1	6
Elevation									
Xia et al (2004)	1	0	1	1	1	0	0	1	5
Swedborg et al (1993)	1	1	1	1	1	0	0	1	6
Laser Therapy									
Piller & Thelander (1998)	1	1	1	0	1	0	1	0	5
Piller & Thelander (1995)	0	1	1	1	1	0	0	1	5
Pump Therapy									
Dubois (2004)	1	0	0	0	1	0	0	0	2
Swedborg (1984)	1	1	1	0	1	0	1	0	5
Zelikovski et al (1980)	1	0	1	0	1	1	0	0	4

Chapter 4. Results of New Exercise Regimes for Limb Oedemas

The following section presents the results of four clinical trials that investigated new exercise regimes for limb oedemas. A general overview is given of the methods undertaken and the measuring techniques used, which were common to all four trials. This is followed by an individual presentation of each clinical trial and the results.

TRIAL METHODS

Before trial commencement, each trial was given ethics approval by the Flinders Medical Centre Clinical Research Ethics Committee (Adelaide, Australia) and informed consent was obtained from each participant.

RECRUITMENT

Participants were recruited through the Flinders Medical Centre (Adelaide, Australia) lymphoedema clinic, vascular and wound management clinics (for leg lymphoedema and venous oedema), local general practitioners and advertising (including posters, pamphlets, radio, television and local newspapers).

INCLUSION/EXCLUSION CRITERIA

- Secondary Leg Lymphoedema: a formal objective diagnosis by a Medical Specialist of manifest secondary leg lymphoedema (≥ 200 mls) of greater than 1 year duration or if less than one year, with significant fibrotic induration in the lymphatic territories. The onset of the lymphoedema being caused by cancer treatment, including surgery for urinary, gastrointestinal, reproductive or melanoma cancer \pm adjunct chemotherapy and/or radiotherapy. Patients with any significant vascular problems (ie: varicose veins, previous deep vein thrombosis) or chronic venous insufficiency were excluded.
- Secondary Arm Lymphoedema: a formal objective diagnosis by a Medical Specialist of manifest secondary arm lymphoedema (≥ 200 mls) of greater than 6 month duration. The onset of the lymphoedema being caused by breast cancer treatment, including surgery (total or partial mastectomy) with axillary clearance \pm adjunct chemotherapy and/or radiotherapy.
- Venous Leg Oedema: a formal objective diagnosis by a Medical Specialist of manifest leg oedema (≥ 200 mls) subsequent to chronic venous insufficiency of greater than 1 year duration. Patients who had multiple abdominal surgeries (which could have damaged lymphatic drainage through the area) or surgery for urinary, gastrointestinal, reproductive or melanoma cancer were excluded.

Any patients with swelling related to cardiac, kidney or hepatic failure, primary lymphoedema or lipoedema as diagnosed by a Medical Specialist were excluded. All participants were required to be over 18 years of age, malignancy and cellulitis free at time of trial entry and to have an adequate range of limb movement, so that volume measurements could be taken.

Participants were asked not to undertake active treatment (ie: manual lymphatic drainage, hydrotherapy, laser therapy or pump therapy) prior to trial entry and were also asked not to undertake these active treatments during the trial period. Those participants who already wore compression garments (this ranged from 20 – 40% of participants) or who were taking oral diuretics were not excluded and were instructed to continue these activities, as it was deemed unethical to cease these treatments.

WITHDRAWAL CRITERIA

Participants were withdrawn from the trials under the following circumstances:

- Upon the participant's request.
- An inability to meet the treatment or measurement schedule.
- Development of cellulitis, in which case the participant would be referred back to their general practitioner for appropriate treatment.
- Cancer recurrence, in which case the participant would be referred back to their oncology specialist for appropriate treatment.
- Development of a medical condition, the commencement of medication or an injury which could significantly impact upon limb swelling.

MEASUREMENTS

The following measurements were taken in all four clinical trials:

- Perometry: The perometer (Pero-systems[®], Germany; figure 4.1a) is a volume measuring system that is based upon a square measuring frame that contains rows of infra-red light emitting diodes on two sides and rows of corresponding sensors on the opposite two sides. The participant sits at one end with the limb resting centrally on an adjustable support. To take the measurement, the frame is moved along the length of the limb from distal to proximal and then back to distal. The limb casts shadows in two planes and using the cross-sectional information obtained, a computer software program builds up a whole arm volume and circumferential picture (at 4mm intervals).

Perometry has been shown to be highly reproducible (Stanton, Northfield, Holroyd et al 1997) accurate (Moholkar & Fenelon 2001; Tierney, Aslam, Rennie et al 1996) and reliable (Labs, Tschoepl, Gamba et al 2001; Stanton et al 1997; Leduc, Klien, Rasquin et al 1992), with one clinical trial quoting an alpha reliability of 0.9998 (Moholkar & Fenelon 2001). The technique is considered to be more accurate in comparison to tape measurements (Stanton et al 1997; Tierney et al 1996) and has been tested on both healthy volunteers and patients with oedema related conditions (Labs et al 2001; Moholkar & Fenelon 2001; Tierney et al 1996). Disadvantages of this technique include; the inability to always measure the whole limb (as the frame may not fit right into the axilla or groin) and the need for the participant to have a reasonable range of movement, so that they can abduct their leg or shoulder for the measurement to be performed.

Figure 4.1.a. Perometer (Pero-systems[®], Germany); demonstrating the square measuring frame, tracking system and the adjustable limb support

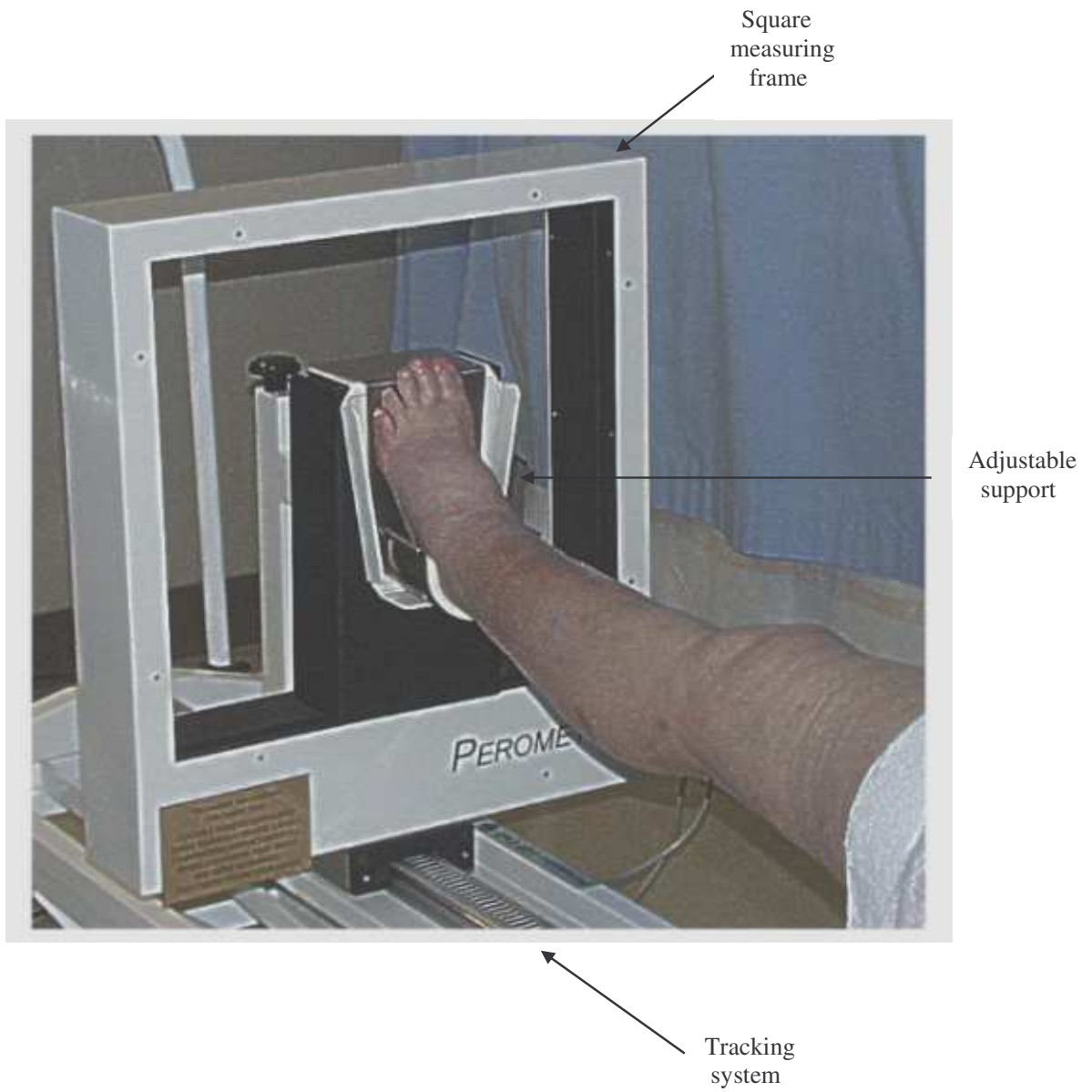

- Bioimpedance: was measured with an InBody 3.0[®] system (figure 4.1.b) manufactured in Korea by Biospace Ltd[®]. The Inbody 3.0[®] is a multi-frequency body and segmental analyser (5kHz - 500kHz) where the participant stands erect on electrode footplates and holds electrodes in the hands, resulting in eight electrode contact sites. The fixed eight point contact overcomes the problems with variable electrode placement and surface area contact. The multi-frequency technique employed moves through both the intra and extracellular compartments, accurately quantifying total body fluid and extracellular fluid in the extremities. This technique also has the ability to distinguish the gain or loss of fluid from fat and muscle (Mikes et al 1999). This not only provides information on the fluid content of the oedematous limb but also provides information on general body composition and components which maybe negatively impacting upon lymphatic and/or venous drainage (such as obesity).

The multi-frequency technique has been shown to be reproducible (Ward, Byrne, Rutter et al 1997; Cha, Chertow, Gonzalez et al 1995) and to have minimal inter-operator variability (Cornish, Chapman, Hirst et al 2001). Previous studies have also proven the validity of multi-frequency bioimpedance in measuring segmental fluid in lymphoedema patients (Moseley, Piller & Carati 2002; Cornish et al 2001; Cornish, Bunce, Ward et al 1997, Ward et al 1996; Watanbe, Miura, Inoue et al 1989), with bioimpedance being considered more accurate in distinguishing the extracellular to intracellular fluid ratio of the limb in comparison to total limb volume measurements (Ward et al 1997: Ward, Bunce, Cornish et al 1992).

Figure 4.1.b. InBody 3.0[®] (Biospace Ltd[®], Korea) multi-frequency (5-500Hz) bioimpedance machine; demonstrating the data display screen and hand and feet electrodes

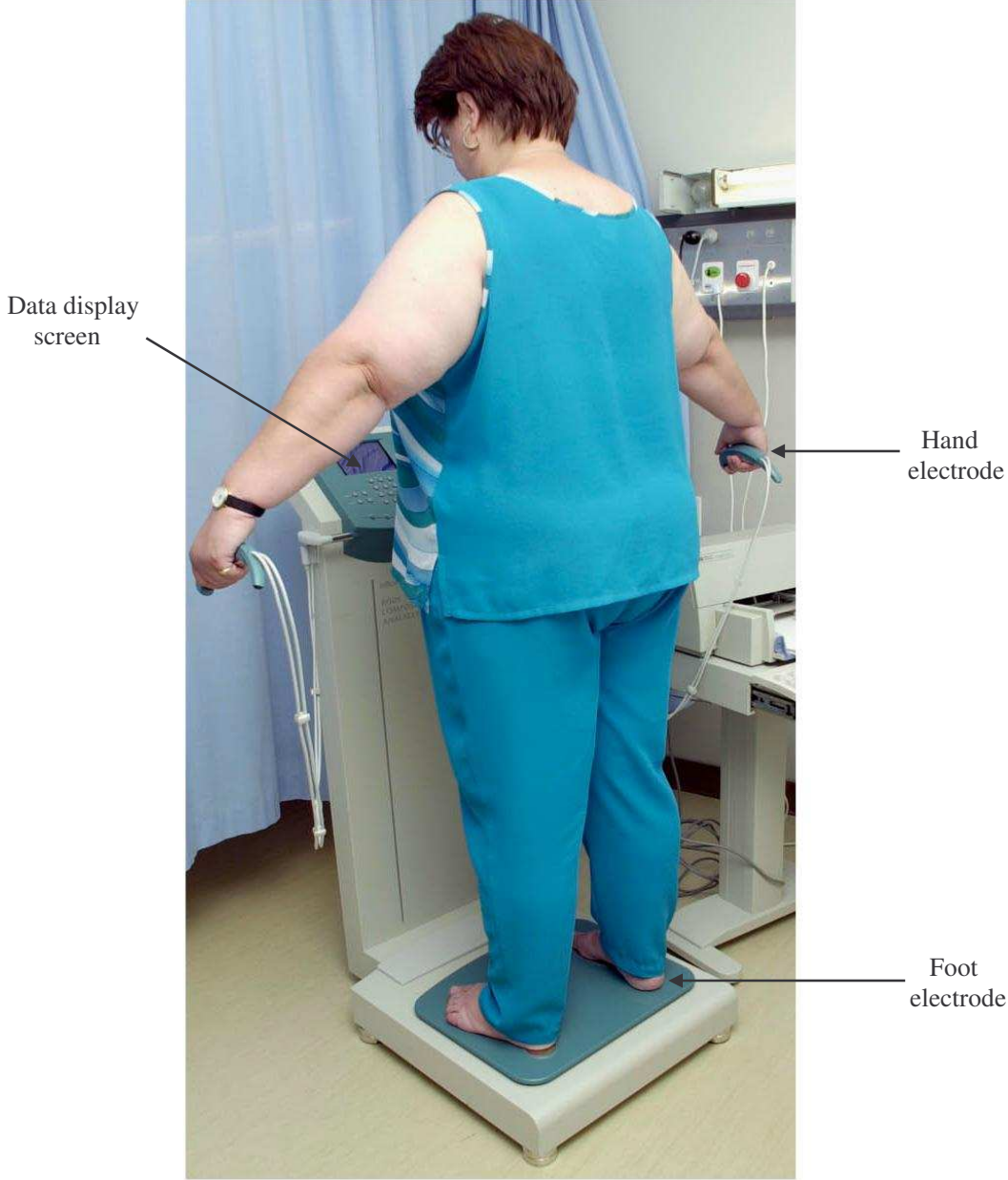

- Tonometry: The tonometer (Flinders Medical Centre Biomedical Engineering, Australia; figure 4.1.c) consists of a central plunger (1 cm diameter) weighted to a mechanical load of 275.28 gms/cm², operating through a footplate that rests on the surrounding skin and applies a load of 12.2 gms/cm². Thus, the plunger applies a differential pressure of 263gms/cm², and the degree of penetration of the plunger (arbitrary units) is measured by a micrometer on a linear scale.

This technique is used to measure the resistance to the applied pressure, giving an indication of the compliance of the dermis and extent of fibrotic induration (Stanton et al 2000; Liu & Olszewski 1992; Clodius, Deak & Piller 1976) in the different lymphatic territories (see table 4.1a. for the measurement technique used for the arm and leg lymphatic territories). The tonometer has been used extensively to measure lymphoedematous limbs and responses to treatment (Carati et al 2003; Chang, Gan, Fu et al 1996; Piller & Thelander 1996; Chen, O'Brien, Pribaz et al 1988; Piller, Morgan, Casley-Smith 1988; Piller & Clodius 1976) and may also give an indication of the fibrotic induration that occurs in the late stages of chronic venous insufficiency.

Figure 4.1.c. Tonometer (Flinders Medical Centre Biomedical Engineering, Australia) demonstrating the mechanical loading, micrometer linear scale and foot plate

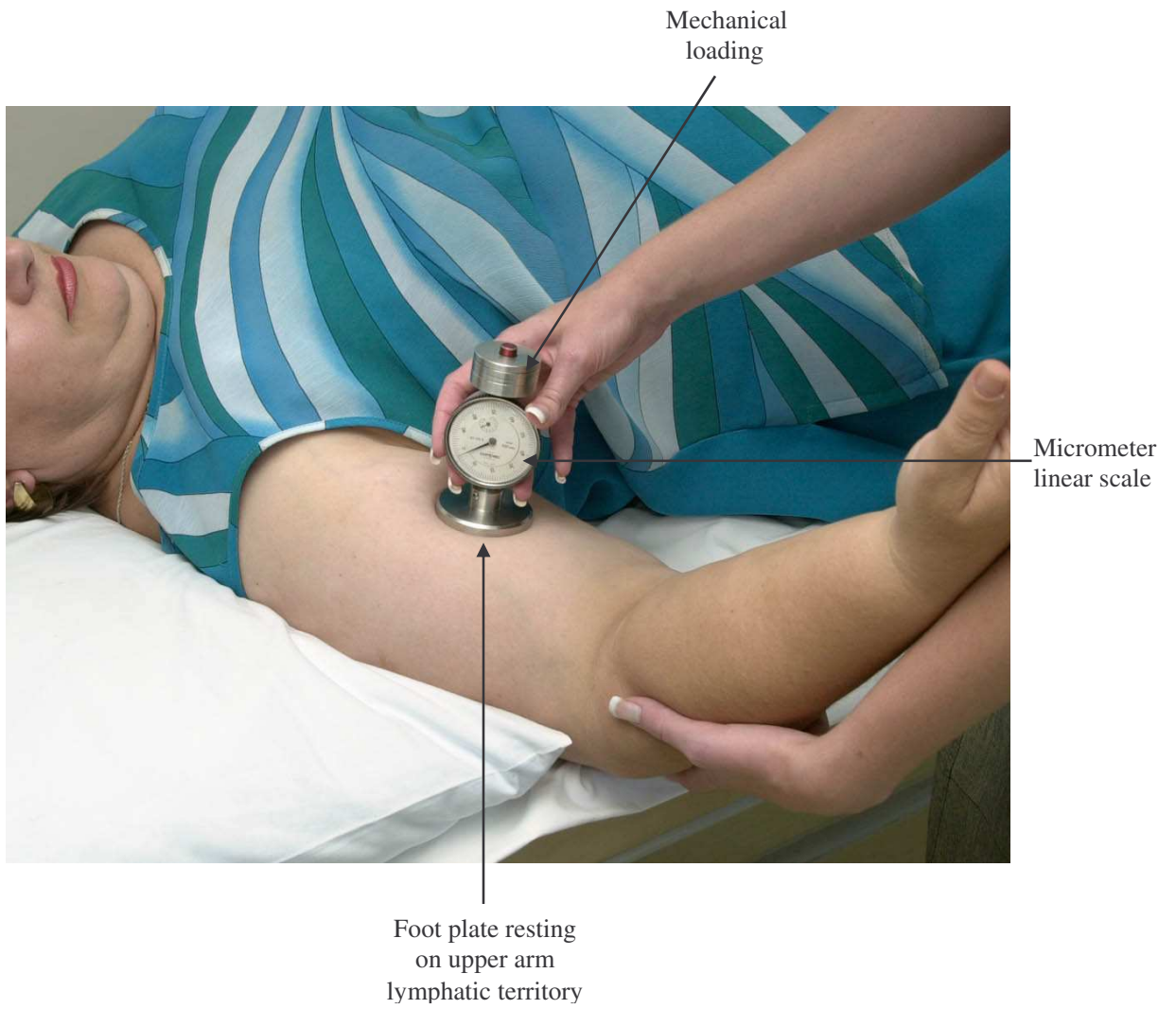

Table 4.1.a. Tonometry measurement technique for each lymphatic territory in the arm and leg

Territory	Technique
Arm	
Forearm	Middle of territory, 10cms distal from the cubital fossa
Upper arm	Middle of territory, 10cms proximal from the cubital fossa
Anterior Thorax	Midclavicular line, 5cms distal from the clavicle
Posterior Thorax	5cms distal of the tip of the scapula
Leg	
Anterior Thigh	Middle of territory, 10cms proximal from the mid-patella
Posterior Thigh	Middle of territory, 10cms proximal from the popliteal crease
Calf	Middle of territory, 10cms distal from the popliteal crease

- Subjective measurements: a questionnaire was administered which assessed the participants' subjective limb symptoms, including; pain, heaviness, tightness, pins and needles, cramps and burning sensations. Participants also rated their perceived limb skin dryness and limb size. This questionnaire utilized a 0-10 scale as previously used in the validated McGill Quality of Life Questionnaire (Lo 2001; Cohen 1997), where zero equated to no problem and 10 was rated as the worst imaginable problem.

Calculation of Actual Oedema & Percentage Change

Actual oedema was calculated according to the following calculations (Swedborg 1984):

Actual oedema:

$$\text{Actual oedema at time}_{(x)} = \frac{\text{lymphoedema limb vol. at time}_{(x)} - \text{normal limb vol. at time}_{(x)}}{\text{normal limb vol. at time}_{(x)}}$$

Percentage change in actual oedema:

$$\% \text{ oedema change at time}_{(x)} = \frac{\text{actual oedema at time}_{(1)} - \text{actual oedema at time}_{(2)}}{\text{actual oedema at time}_{(1)}} \times 100$$

Secondary Leg Lymphoedema & Venous Leg Oedema Only:

- Quality of Life Questionnaire: this questionnaire was administered to assess the impact of the limb swelling and its associated problems on the participant's life and whether this was altered at treatment cessation. Using the validated 0-10 point scale, it specifically assessed physical, psychological, social, recreational and emotional aspects. The questions used were based upon elements derived from the Short-Form 36 (SF-36) questionnaire, which has been extensively used and validated in various disease states (Arnold et al 2000; Failde & Ramos 2000), including lymphoedema (Azevedo et al 2001).

Secondary Leg Lymphoedema Only:

- Lymphoscintigraphy: volunteers were asked to undergo lymphoscintigraphy which depicts abnormalities in the leg lymphatic circulation and evaluates lymphatic transport (Bernas et al 2001; Witte & Witte 1999; Cambria et al 1993). This test was performed before and after 3 weeks of treatment to assess whether the treatment regime had had any impact upon these parameters. Radioactive trisulphide colloid preparation was injected subdermally into the first interdigital space and laterodorsal areas of each foot. After the injection the participant was instructed to exercise their legs in a cycling motion in the supine position for 5 minutes. The patient was then scanned with a gamma camera over a 5 hour period to quantify the rate and spread of the radioactivity (measured in MBqs) from the injection site to the inguinal nodes. The participant was also required to fill in an activity sheet at the first visit so that the same activities could be replicated at the second visit.

TRIAL ONE

The effect of the Sun Ancon[®] Chi Machine[®] Aerobic Exerciser which delivers leg elevation and passive exercise for those with chronic secondary leg lymphoedema

Moseley, A., Piller, N., Carati, C. & Esterman, A., Jun 2004, 'The Sun Ancon Chi Machine Aerobic Exerciser: a new patient focused, home based therapy for people with chronic secondary leg lymphoedema', Lymphology, vol. 37, 53-61.

Abstract

A significant proportion of those who survive lower torso cancer treatments will go on to develop clinically discernible bilateral or unilateral leg lymphoedema. Although beneficial treatments exist for this condition, many are expensive and involve visits to outpatient clinics or allied health professionals - making the patient partially dependant upon others for treatment and maintenance. This trial tested the efficacy of the Sun Ancon[®] Chi Machine[®] Aerobic Exerciser, a new home based therapy that delivered both elevation and passive exercise to the legs and which was used according to a set regime. Measurements were taken at baseline, weekly intervals and then 1 month after treatment cessation. After three weeks, there were significant reductions in leg volume (330mls; 33% oedema, $p=0.001$), whole body extracellular fluid (300mls; $p=0.019$), weight (0.5kgs; $p=0.039$), subjective leg symptoms (pain; $p=0.04$; tightness; $p=0.00$, heaviness; $p=0.00$) plus perceived skin dryness ($p=0.001$) and limb size ($p=0.00$). Lymphoscintigraphy in a sub-group of volunteers also demonstrated an increase in lymphatic transport in some individuals. Although some of the fluid and symptoms had returned at the 1 month follow up, none of the parameters had returned to pre-treatment levels. This indicates that this equipment may have ongoing beneficial effects.

Aim

This and the next clinical trial tested the effectiveness of a new home based therapy called the Sun Ancon[®] Chi Machine[®] Aerobic Exerciser which delivered both elevation and passive exercise to the legs. It is well established that lymph propulsion and clearance is influenced by varying total tissue pressure (Hevas et al 1997) and that one of the most effective ways of varying tissue pressure is through leg movement. This movement also aids drainage of both lymph and blood from the limb and the reabsorption of inflammation causing proteins (Brennan & Miller 1998).

This study did not include a control group which only lied supine or moved their legs, as the effect of these activities on lymph pressure and flow have already been extensively investigated by Olszewski (1991). From this research and the above mentioned literature it was hypothesised that the Aerobic Exerciser would positively influence drainage from the legs, resulting in a fluid reduction and an improvement in subjective leg symptoms and quality of life. This first trial describes the effect of this therapy on lymphoedematous legs.

Treatment Regime

The Sun Ancon[®] Chi machine[®] Aerobic Exerciser used in the trial comprised an electric motor coupled to a gear mechanism attached to two moulded ankle rests. The patient lies in the supine position (on the floor or firm bed) with the legs slightly elevated and their ankles positioned in the moulded rests. When the exerciser is switched on the ankles are moved from side to side (140 times per minute \pm 10%, at a swing angle of 12^o) delivering elevation and a low impact, passive exercise to the legs (figure 4.1.1).

Each participant used the Sun Ancon[®] Chi machine[®] Aerobic Exerciser in their own home, morning and evening for three weeks adhering to the following regime: days 1-2: 5 minutes per session, days 3-7: 8 minutes per session, days 8-21: 12 minutes per session. The staggered increase in treatment time was used to allow the participants to adapt to the sensation of the machine. Each participant was asked to fill in a log book so compliance to the regime could be monitored.

Figure 4.1.1. The Sun Ancon[®] Chi machine[®] Aerobic Exerciser (Hsin Ten Enterprise[®], Taiwan)

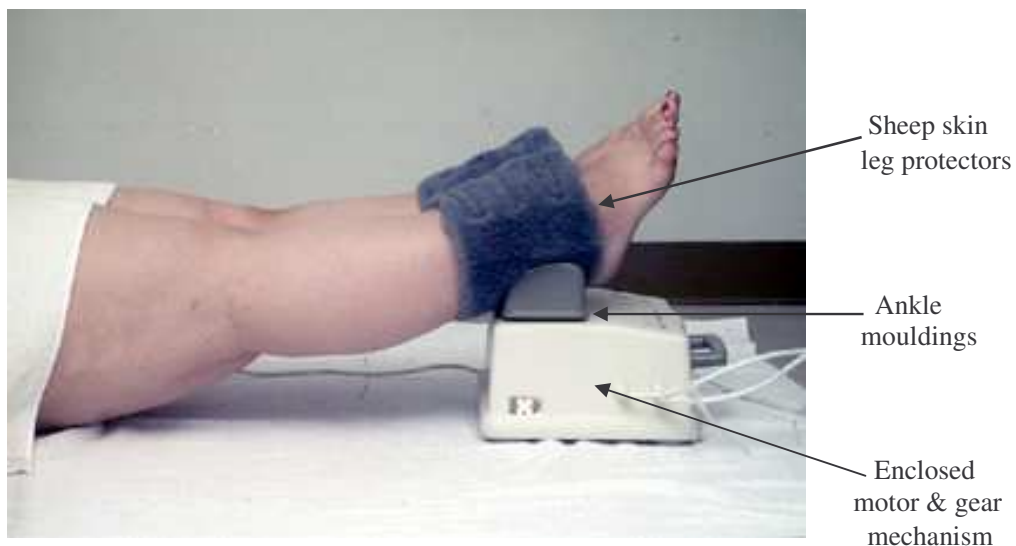

Measurement Schedule

Measurements were taken immediately before study commencement (baseline), at weekly intervals and at 1 month post treatment to assess whether there were any long term treatment benefits. In the majority of cases, the measurements were taken on the same day of the week and at the same time of day.

Analysis

Data was analysed in conjunction with a Clinical Epidemiologist using SPSS (version 10.5.5) to determine differences between baseline, weekly intervals, end of treatment and one month post treatment cessation. As the sample group data was not normally distributed, a two related samples non-parametric Wilcoxon test (Monte Carlo 99%) was used. This test compares the magnitude of differences between pairs, where $p < 0.05$ is statistically significant. Data are presented as median values and quartiles.

Study Population

Thirty three people with chronic secondary leg lymphoedema participated in the trial, twenty eight females and five males aged 39 - 88 years (mean 59 years \pm 13yrs). In this group, 55% of the participants exhibited unilateral swelling, whilst 45% exhibited bilateral swelling.

Results

Leg Changes:

There was a statistically significant leg volume loss in the affected leg(s) as measured by perometry over 3 weeks (median 330mls; 33% oedema; $p = 0.001$; figure 4.1.2a). There was some volume increase (median 100mls; 10% oedema; $p = 0.12$) at the 1 month follow up but this was not back to pre-treatment levels, with the volume at the 1 month follow up still remaining statistically lower than the pre-treatment level ($p = 0.032$). In concert with the total leg volume reduction, bioimpedance demonstrated that there was a fluid reduction in the affected leg(s) after three weeks of treatment (median 120mls; 12% oedema; $p = 0.021$; figure 4.1.2b). Again, some fluid returned at the 1 month follow up (median 90mls; 9% oedema; $p = 0.137$) but this was not back to original pre-treatment levels.

The reduction in leg volume and fluids also resulted in statistically significant improvements in subjective leg symptoms, including pain ($p = 0.04$), tightness ($p = 0.00$), heaviness ($p = 0.00$), skin dryness ($p = 0.01$) and in how the participant perceived the size of their leg(s) ($p = 0.00$) (table 4.1.1). At the 1 month follow up the majority of these symptoms had increased, but not back to original pre-treatment values. No significant differences were detected in the lymphatic territories as measured by tonometry during the trial period.

Figure 4.1.2a. Change in median leg volume (ml's) over three weeks of treatment with the Aerobic Exerciser and then at 1 month follow up, as measured by perometry.

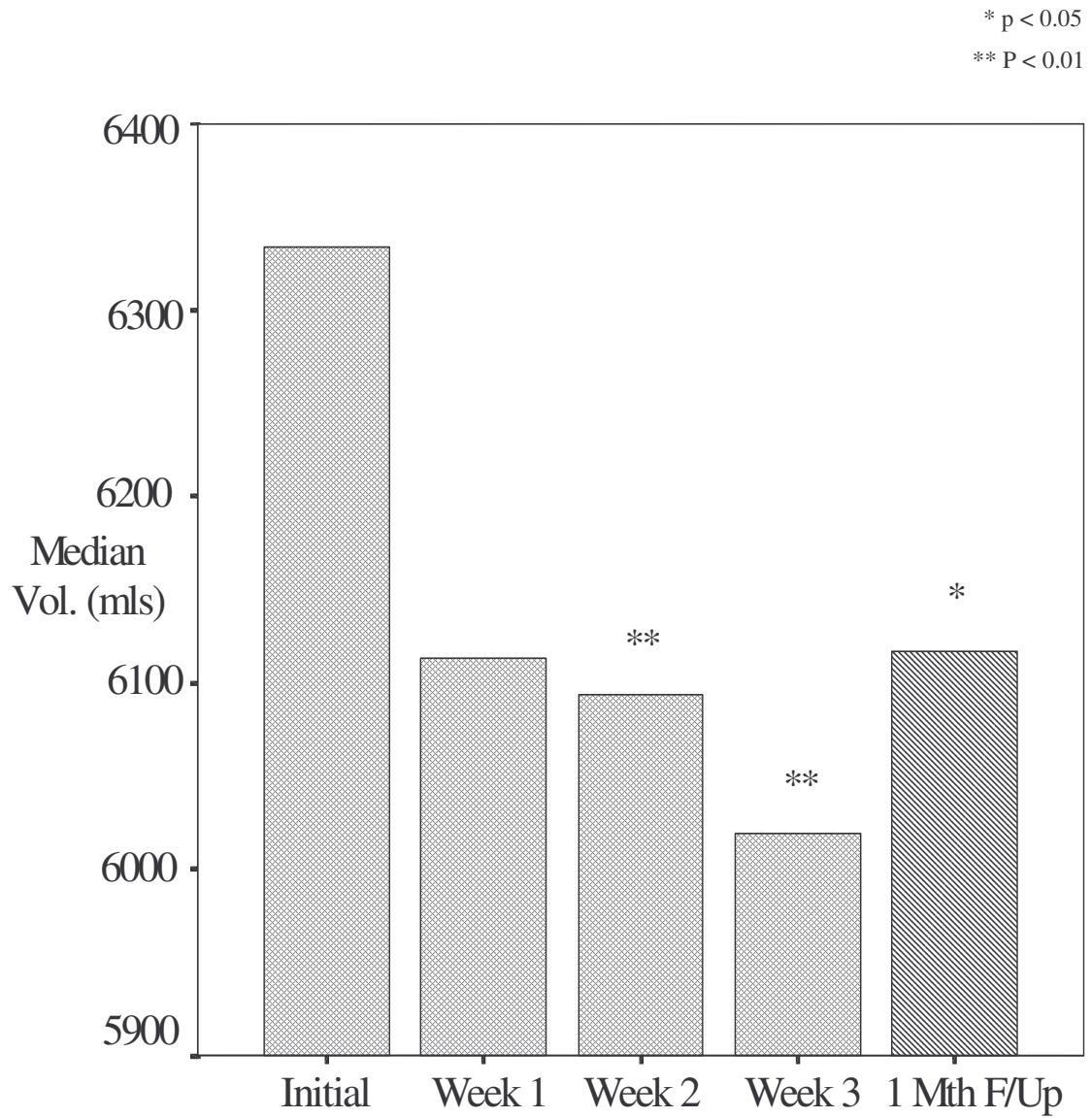

	Initial	End 3 wks	1mthf/up
Percentile 25 th	5137mls	5097mls	5007mls
75 th	6679mls	6478mls	6912mls

Figure 4.1.2b. Change in median leg fluid (ml's) over three weeks of treatment with the Aerobic Exerciser then at 1 month follow up, as measured by bioimpedance

* p < 0.05

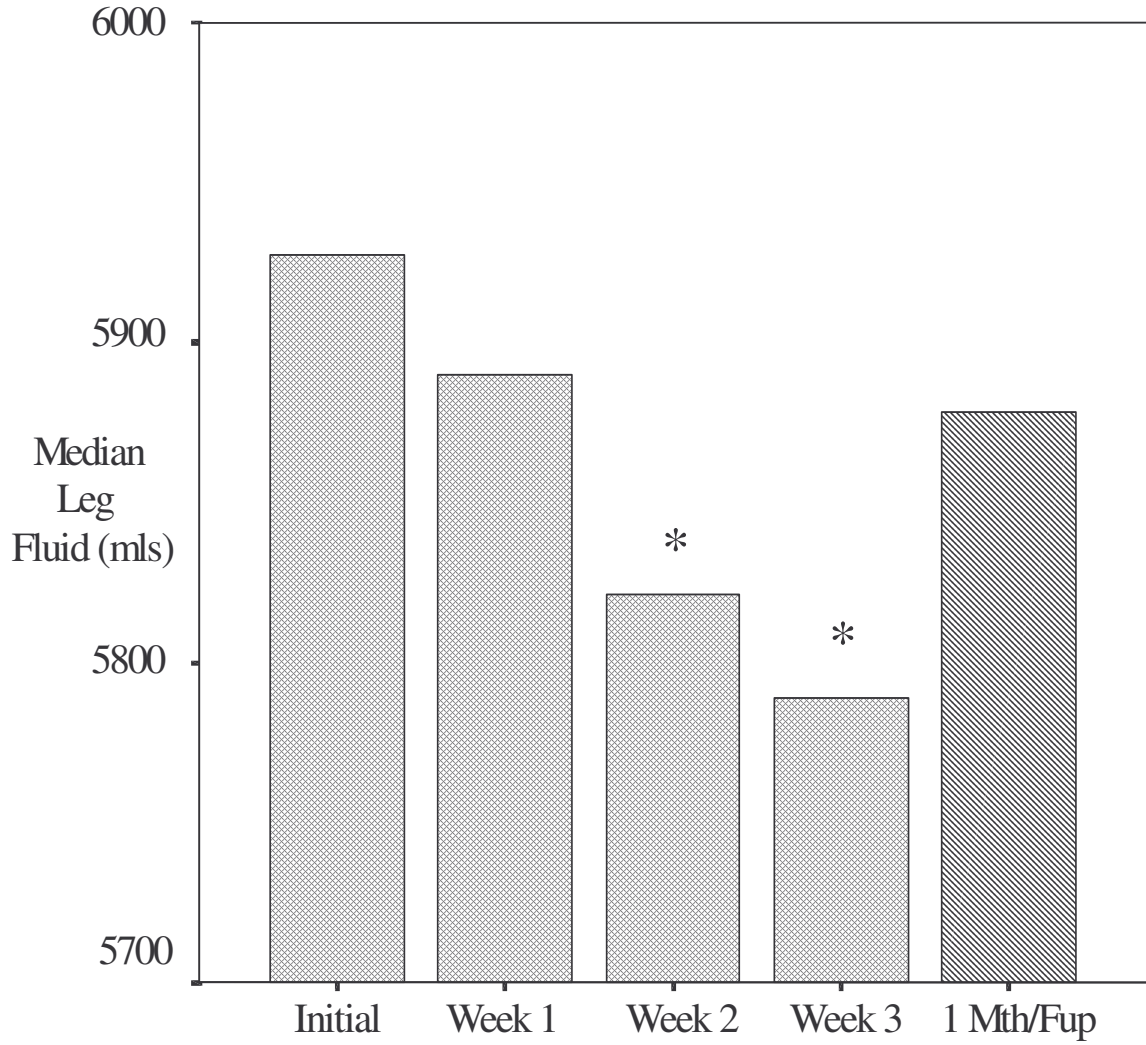

	Initial	End 3 wks	1mthf/up
Percentile 25 th	4935mls	4895mls	4812mls
75 th	6470mls	6358mls	6373mls

Table 4.1.1. Subjective leg symptoms - before and after treatment with the Aerobic Exerciser then at 1 month follow up*

Symptom	Initial	Range	Final	Range	p =	1 month	Range	p =
Pain	3.7	1-5.5	2.0	1-2.8	0.04	3.5	1-5.8	0.12
Tightness	6.0	3-7.5	2.0	1-3.0	0.00	5.0	3-7.0	0.00
Heaviness	5.0	2.5-8	2.0	1-4.8	0.00	5.0	3-7.0	0.00
Cramping	2.5	1-2.5	1.8	1-2.0	0.48	2.2	1-2.8	0.50
Pins & Needles	2.7	1-2.5	1.4	1-2.0	0.08	1.7	1-1.8	0.25
Burning feeling	2.5	1-3.0	1.4	1-2.0	0.07	1.6	1-1.8	0.41
Skin dryness	4.0	1-6.0	2.0	1-4.0	0.01	1.0	1-4.5	0.01
Limb size	7.0	5-8.0	5.0	3-6.8	0.00	5.0	3-7.0	0.23

*based upon a 0 - 10 scale where 0 = no problem and 10 = worse imaginable problem

Whole Body Composition Changes:

There was a steady decline in whole body extracellular fluid volume over the three weeks of treatment (median 300mls; $p = 0.019$; figure 4.1.3a). This loss was sustained at the 1 month follow up, with the difference between the pre-treatment and 1 month follow up values remaining statistically significant ($p = 0.039$). Participants also experienced a reduction in their body weight (median 0.5kgs; $p = 0.015$; figure 4.1.3b). Notably, this weight loss remained stable at the 1 month follow up when compared to end of treatment, even though some fluid had returned to the affected leg(s).

Although some of the weight loss could be attributed to the fluid loss from both the legs and whole body, there were also reductions in percentage body fat and body mass index. Percentage body fat decreased by 0.71% ($p = 0.745$) over three weeks of treatment with this decrease continuing by a further 0.79% ($p = 0.499$) at the 1 month follow up. The groups' body mass index (BMI) also decreased by 0.15 Kg/m^2 after three weeks of treatment ($p = 0.058$). The BMI increased again at the 1 month follow up ($p = 0.93$) but did not returned to the original pre-treatment levels. Changes in the affected leg(s) and whole body composition were also significantly correlated (table 4.1.2).

Figure 4.1.3a. Changes in whole body extra cellular fluid volume (L's) over three weeks of treatment with the Aerobic Exerciser then at 1 month follow up, as measured by bioimpedance

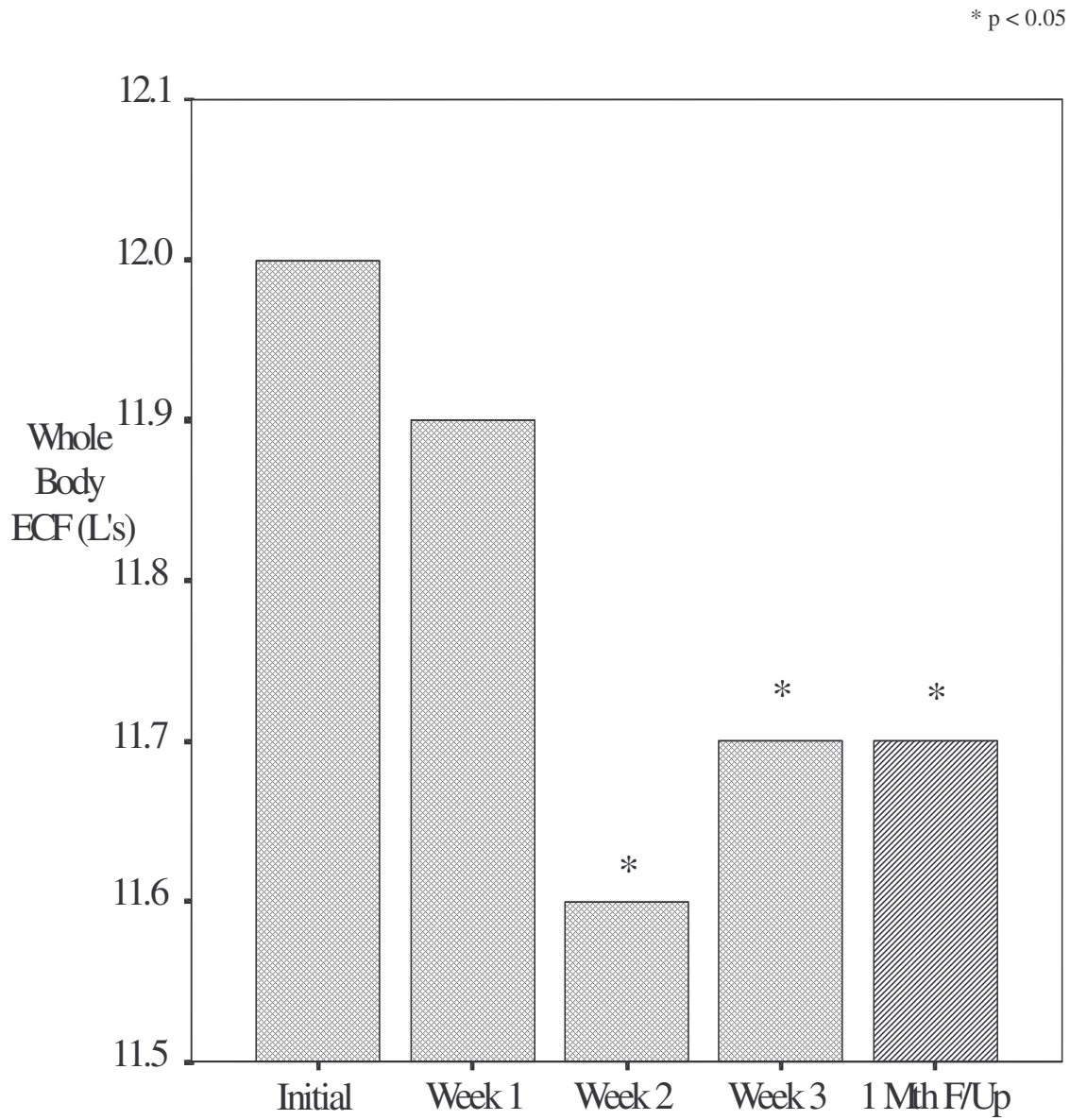

	Initial	End 3 wks	1mthf/up
Percentile 25 th	10.8Ls	10.6Ls	10.4Ls
75 th	13.3Ls	13.7Ls	13.3Ls

Figure 4.1.3b. Changes in body weight (Kg's) over three weeks of treatment with the Aerobic Exerciser then at 1 month follow up, as measured by bioimpedance

* p < 0.05

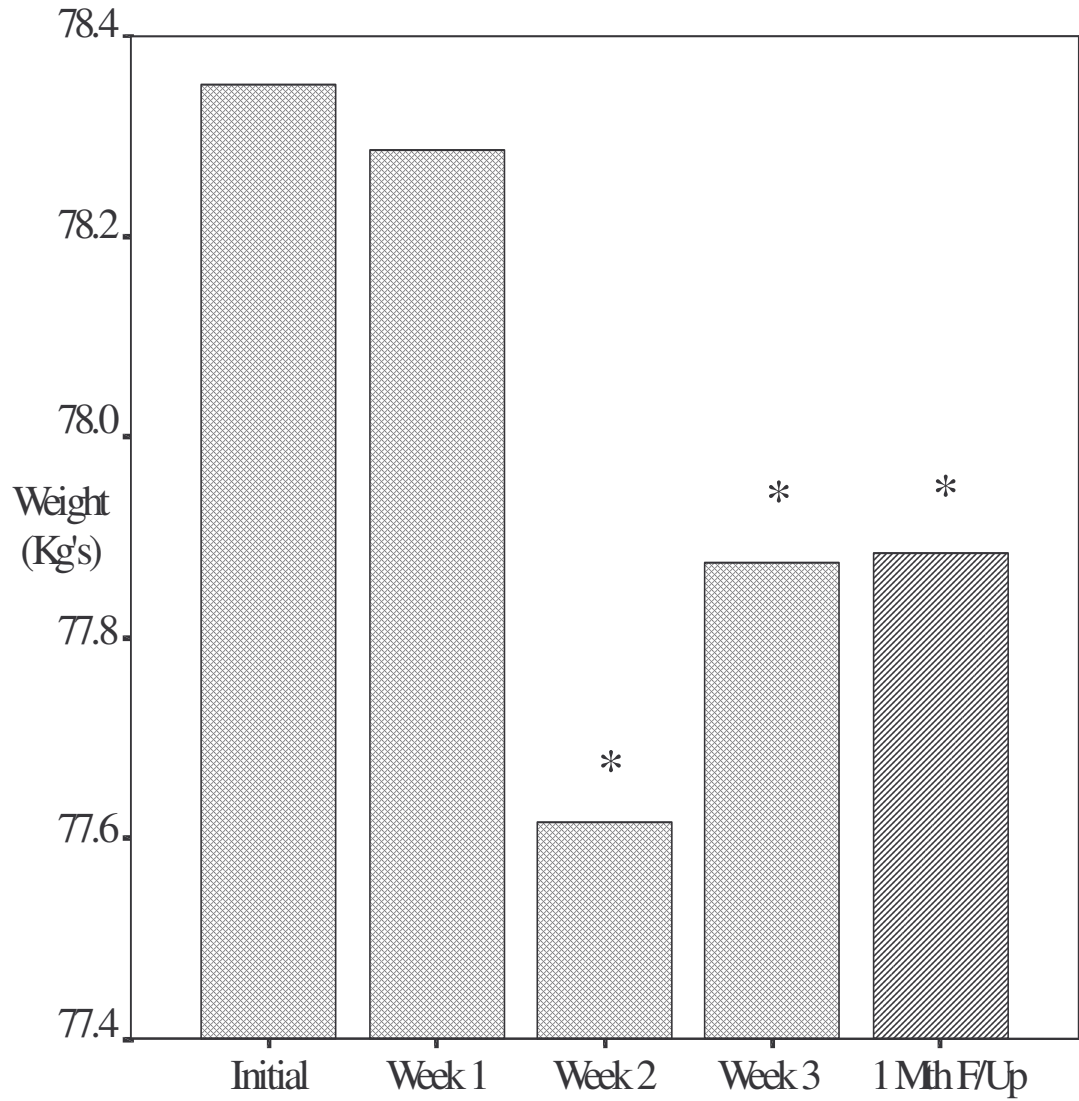

	Initial	End 3 wks	1mthf/up
Percentile 25 th	66.7kgs	68.3kgs	65.2kgs
75 th	87.6kgs	87.6kgs	88.4kgs

Table 4.1.2. Correlations of leg changes (volume, fluid & symptoms) and body compositional changes after 3 weeks of treatment with the Aerobic Exerciser

	Pearson Coefficient	Significance
Median leg volume change v's body ECF change	0.495	0.040
Median leg fluid change v's leg tightness change	0.401	0.026
Median leg fluid change v's leg heaviness change	0.477	0.006
Weight change v's median leg volume change	0.478	0.006
Weight change v's body mass index	0.890	0.000

Quality of Life Changes:

There were significant improvements in particular (patient reported) quality of life domains after three weeks of treatment, these included; limb range of movement, ability to climb stairs, sleep quality, self consciousness, self and family view and depression associated with the condition. Patients also recorded a high treatment satisfaction and an increased feeling of control over their condition when using the Aerobic Exerciser (table 4.1.3a). The improvements in some of the quality of life domains also significantly correlated with improvements in reported leg heaviness and tightness and perceived leg size (table 4.1.3b).

Table 4.1.3a. Improvements in certain quality of life domains after three weeks of treatment with the Aerobic Exerciser

Parameter	Pre	Post	% Improvment^t	p =
Range of Movement	5.4 (± 3.1)	4.0 (± 3.3)	74.1%	0.052
Ability to Exercise	4.9 (± 3.2)	3.0 (± 2.9)	61.2%	0.003
Climbing Stairs	3.9 (± 3.0)	2.3 (± 2.4)	59.0%	0.015
Difficulty Sleeping	3.4 (± 3.1)	1.9 (± 1.9)	55.9%	0.003
Self Consciousness	7.1 (± 3.2)	5.6 (± 3.1)	78.9%	0.002
Self View	3.9 (± 2.9)	2.8 (± 2.3)	71.8%	0.034
Family/Partner View	2.3 (± 2.5)	1.3 (± 1.4)	56.5%	0.011
Impact on Daily Life	5.5 (± 2.5)	3.5 (± 3.2)	63.6%	0.001
Depression	3.4 (± 2.8)	2.4 (± 1.9)	70.6%	0.020
Treatment Satisfaction	7.1 (± 1.9)	8.4 (± 1.6)	84.5%	0.039
Control Over Condition	4.8 (± 2.8)	7.2 (± 3.0)	66.7%	0.000

Table 4.1.3b. Correlations in quality of life improvements with subjective leg symptom improvements after 3 weeks of treatment with the Aerobic Exerciser

Correlations	r	p
Change in ability to climb stairs v's change in leg tightness	0.364	0.037
Change in ability to climb stairs v's change in leg heaviness	0.360	0.039
Change in ability to climb stairs v's change in leg size	0.384	0.027
Change in self consciousness v's change in leg size	0.480	0.018
Change in family view of patient v's change in leg size	0.443	0.010

Lymphoscintigraphy:

Of the eight participants who voluntarily underwent lymphoscintigraphy immediately prior to and after 3 weeks of treatment, three participants showed an increased MBq count and lymphatic transport function in the post treatment scan. Figures 4.1.4a and 4.1.4b show an example of a participant who showed improvements in both the clinical measurements and lymphoscintigraphy. The post treatment graph of this participant shows how lymphatic transport was increased (as measured by increased MBq counts) after 3 weeks of treatment. The participants (n = 5) who did not demonstrate an improvement in the clinical trial had quite significant dermal back flow (retrograde flow into the dermis via the initial lymphatic capillaries) in both the pre and post lymphoscintigraphy scans, indicating significant drainage problems. This also provides an explanation as to why the Sun Ancon[®] Chi Machine[®] Aerobic Exerciser may work more effectively in some individuals when compared to others.

Figure 4.1.4a. Lymphoscintigraphy: Exemplar of MBq counts indicating radioactivity transit through the affected leg before and after treatment with the Aerobic Exerciser.

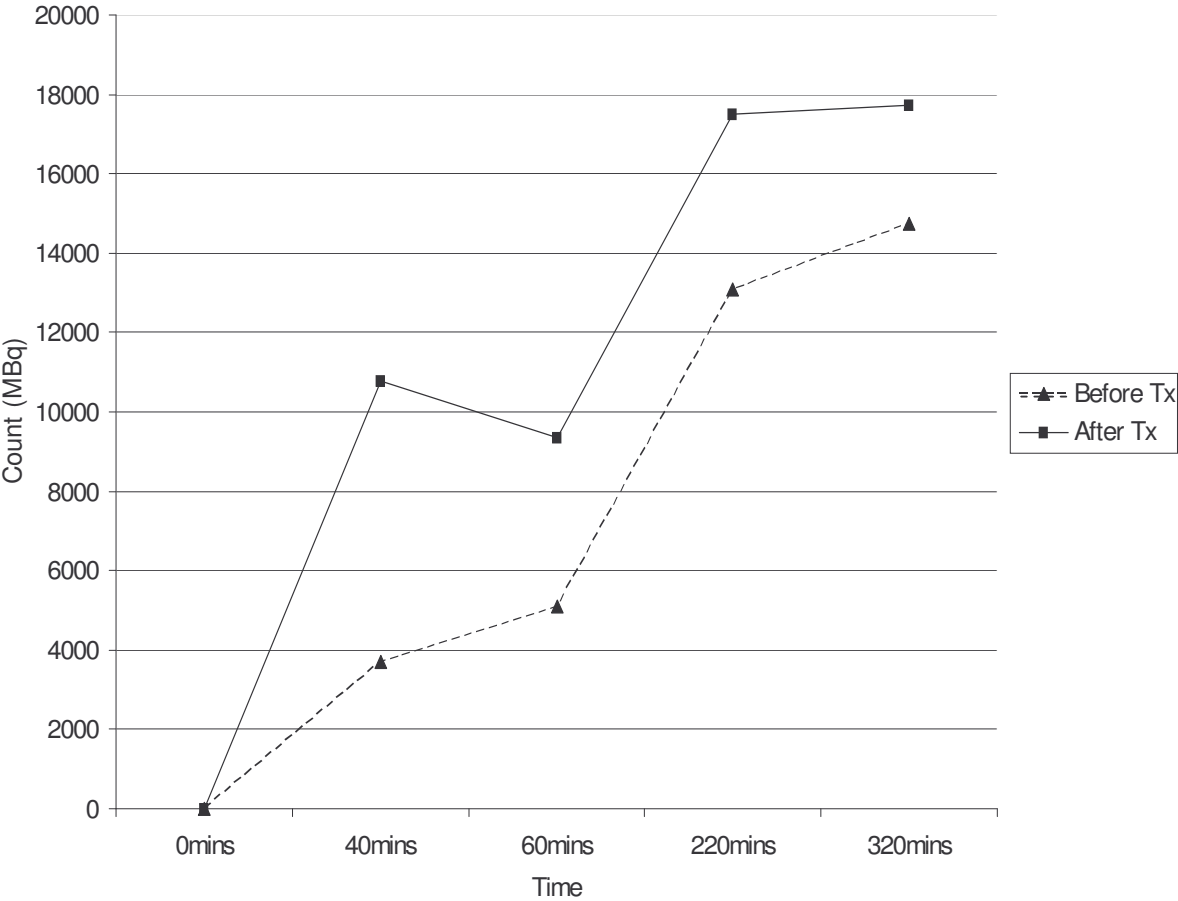
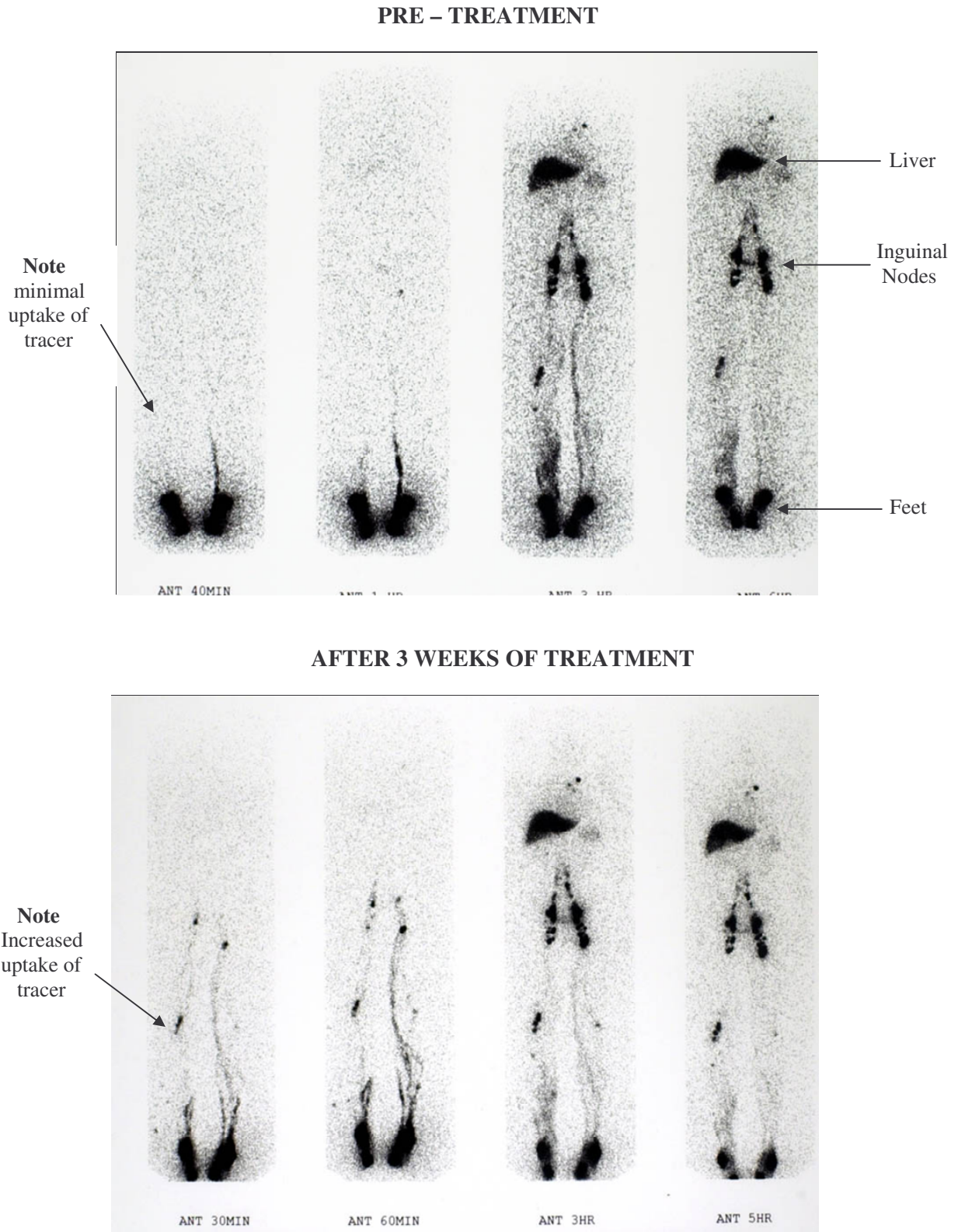

Figure 4.1.3b. Example of a participant who had an improvement in lymphoscintigraphy after 3 weeks of Aerobic Exerciser use.



Compliance & Side Effects

Although a few participants missed some days in the treatment regime due to sickness, there was an overall 95% compliance rate with the regime.

The most commonly reported side effects were knee pain (17%), dizziness immediately after treatment session (8%) and neck pain (10%). A small percentage (8%) of participants found the ankle mouldings to be uncomfortable on their legs. The neck and knee pain generally occurred in those who had pre-existing conditions such as arthritis and was eliminated by putting a pillow under these areas to give them support whilst using the Aerobic Exerciser. Giving participants sheep skin ankle protectors that padded the lower legs (refer to figure 4.1.1) alleviated leg discomfort caused by the mouldings.

Discussion

Overall the group experienced a statistically significant fluid loss and volume reduction in their affected leg(s) and a decrease in whole body extracellular fluid volume after three weeks of treatment. There was also a statistically significant weight loss over three weeks of treatment along with clinically significant reductions in participants' percentage body fat and subsequently their body mass index. This is of particular importance as many people who have lymphoedema find it difficult to exercise and therefore control their weight (which puts an extra load on the already compromised lymphatic system). The Aerobic Exerciser provides a way to mimic exercise and loose some weight without the need to undertake strenuous exercise.

With the loss of fluid there were also improvements in perceived leg symptoms. In particular after 3 weeks of treatment there were statistically significant improvements in leg pain, tightness, heaviness and perceived skin dryness and leg size. Symptoms such as cramping, burning feelings and pins and needles did improve with treatment, but were not statistically significant. Participants' also rated on the quality of life questionnaire that it was easier to undertake physical activities such as climbing stairs and exercising. This resulted in a more positive body image, with participants viewing themselves as less impaired and an accompanying reduction in depression associated with the condition.

Lymphoscintigraphy performed in eight participants before and after treatment showed improvement in lymphatic transport capacity in three participants, whilst the remaining five who initially demonstrated significant dermal back flow (and therefore significant drainage problems) did not demonstrate an improvement in lymphatic transport. This indicates one of the possible modes of action of the Aerobic Exerciser, stimulating the lymphatics in those who do not have a major obstruction but being unable to stimulate them in those who may have a significant blockage (as indicated by dermal back flow). In those individuals who do have a major blockage, the blockage itself may need to be addressed first (maybe via laser or massage) and the Aerobic Exerciser then used as an adjunct therapy.

Although leg volume, total leg fluids, whole body extracellular fluid and leg symptoms demonstrated some increase after 1 month of treatment cessation, none of these parameters returned to original pre-treatment levels. This, and the fact that some parameters such as leg volume and whole body extracellular fluid volume remained statistically lower than pre-treatment levels at the 1 month follow up indicates that the Aerobic Exerciser may have beneficial effects that last at least one month. However, for optimal results the machine should

probably be used on a continual basis for leg maintenance. Although there were some side effects from using the machine, these only occurred in a relatively small proportion of participants and generally occurred in those with pre-existing joint problems. Generally this form of therapy was well received and tolerated.

TRIAL TWO

The effect of the Sun Ancon[®] Chi Machine[®] Aerobic Exerciser which delivers leg elevation and passive exercise for those with venous oedema of the legs

Moseley, A., Piller, N., Carati, C. & Esterman, A., 2003, 'The impact of the Sun Ancon Chi Machine Aerobic Exerciser on chronic oedema of the legs', Aus & NZ J Phlebology, vol. 7, no. 2, 5-10.

Abstract

This trial tested the effectiveness of a home based piece of equipment (the Sun Ancon[®] Chi Machine[®] Aerobic Exerciser) that delivered passive exercise and elevation to oedematous legs. Twenty two participants used the equipment in their own home morning and evening for three weeks according to a set regime. Measurements of leg volume, segmental fluids, symptoms and body composition were taken immediately before trial commencement, at weekly intervals and then 1 month post treatment. After 3 weeks of treatment there were statistically significant reductions in segmental leg fluids (220mls; 22% oedema; $p=0.034$), weight (1.49kgs; $p=0.02$), body fat ($p = 0.01$) and subjective leg symptoms, including pain ($p=0.01$), tightness ($p=0.02$), heaviness ($p=0.02$), cramping ($p=0.01$), burning feelings ($p=0.00$), skin dryness ($p=0.03$) and perceived limb size ($p=0.00$). There were also reductions in body fat, BMI, whole body ECF and truncal fluids. Although some parameters increased at the 1 month follow up, none had returned to pre-treatment levels. In conclusion, the Sun Ancon[®] Chi Machine[®] Aerobic Exerciser is an effective, home based therapy for venous oedema sufferers.

Aim

Although well established treatments exist for venous insufficiency and oedema, ranging from compression stockings (Van Geest et al 2000), hydrotherapy (Clement 2000), oral preparations - including the newer micronized purified flavanoid fraction drugs (Olszewski 2000), sclerotherapy (Gloviczki et al 1999) and surgery (Clement 2000), many are expensive (Ruckley 1997) and ongoing. As the patient is frequently reliant upon outpatient health care clinics for treatment and maintenance, there needs to be a focus on adjunct home based therapies which may help to alleviate some of the symptoms of this condition. Therefore this trial investigated the effectiveness of the Sun Ancon[®] Chi Machine[®] Aerobic Exerciser for leg venous oedema, a home based therapy which delivers low impact, passive exercise plus slight elevation to the legs.

Treatment Regime

Same as trial one.

Measurement Schedule

Same as trial one.

Analysis

Same as trial one.

Study Population

Twenty two chronic venous oedema sufferers participated in the trial, seventeen females and five males aged 37-80 years (mean 59 years). In this group 52% of the participants exhibited bilateral oedema whilst 48% exhibited unilateral oedema. Those who participated had a formal diagnosis of venous insufficiency with oedema from a health care professional, with the participants having a CEAP classification between 3 – 5. The majority of participants had undergone a doppler ultrasound that confirmed chronic venous insufficiency. The causes of the oedema were previous deep vein thrombosis (n = 10), varicose veins (n = 8) and vascular disease (n = 4).

Results

Affected Leg(s) Change:

At the end of three weeks of treatment the median affected leg volume (as measured by perometry) had decreased by 90mls (9% oedema; $p = 0.09$). The group also experienced a reduction in segmental fluid in the affected leg (as measured by bioimpedance) over the three weeks of treatment (median 220mls; 22% oedema; $p = 0.034$; figure 4.2.1). Although it would be anticipated that some of this fluid would have returned at the 1 month follow up, the fluid loss was actually maintained, with the 1 month value remaining statistically lower than the pre-treatment value ($p = 0.030$).

The reduction in leg volume and fluid also resulted in statistically significant improvements in all (except pins and needles) reported subjective leg symptoms (table 4.2.1). At the 1 month follow up only leg cramping, perceived skin dryness and limb size were significantly lower in comparison to baseline. With the other symptoms, there were no significant differences at this time. No significant differences were detected in the leg tissues (in the major lymphatic territories) as measured by tonometry during the trial period.

Figure 4.2.1. Changes in median leg fluid (ml's) over three weeks of treatment with the Aerobic Exerciser then at 1 month follow up, as measured by bioimpedance

* p < 0.05

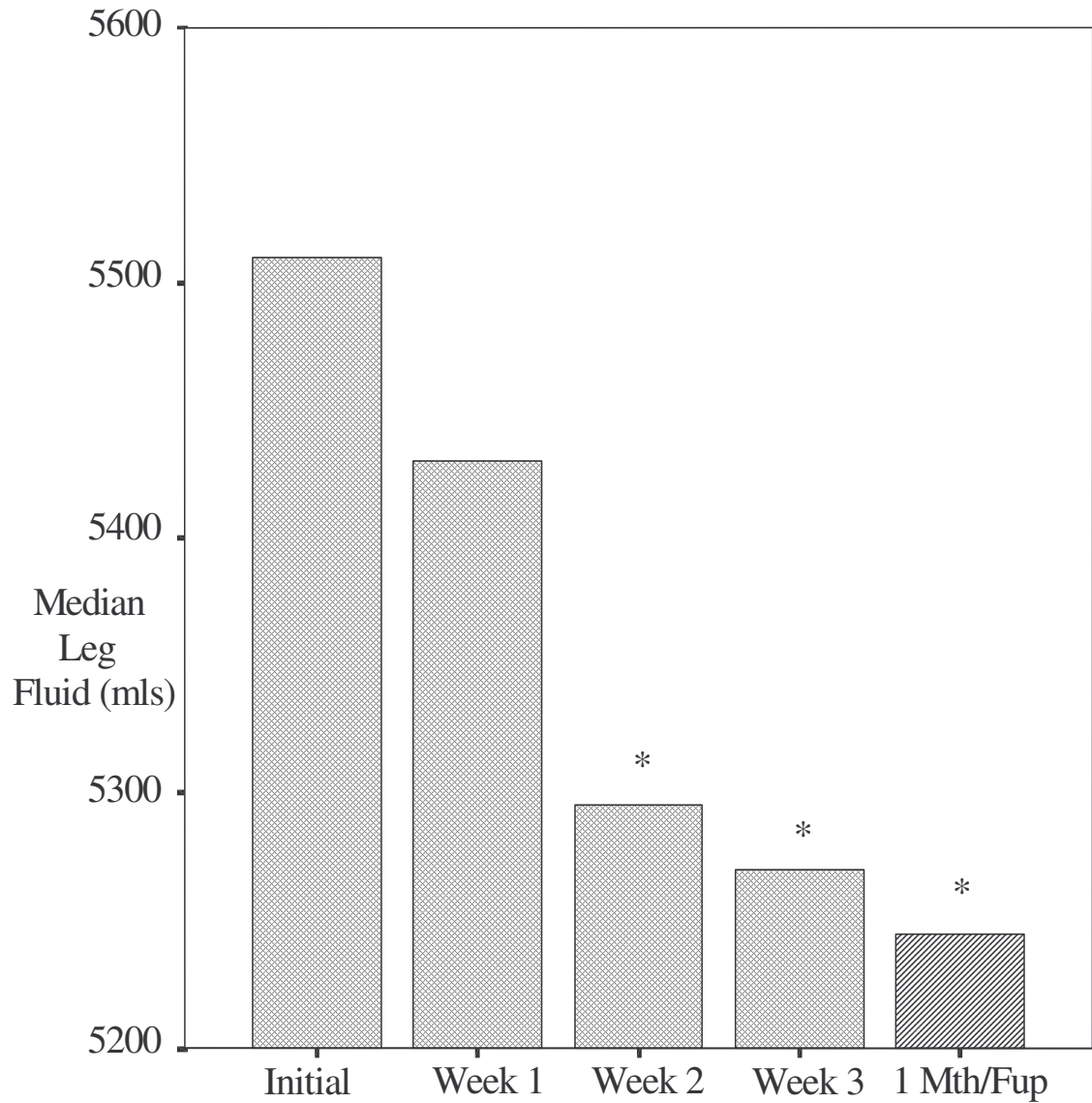

	Initial	End 3 wks	1mthf/up
Percentile 25 th	4951mls	4788mls	4870mls
75 th	6655mls	7006mls	6470mls

Table 4.2.1. Subjective leg symptoms at the beginning and end of 3 weeks of treatment with the Aerobic Exerciser and then at 1 month follow up*.

Symptom	Initial	Range	Final	Range	p =	1 month	Range	p = **
Pain	4.0	1-7.0	1.0	1-2.3	0.01	2.5	1-5.0	0.29
Tightness	5.0	1-7.3	2.0	1-5.0	0.02	3.0	1-5.0	0.19
Heaviness	5.0	1.8-8	2.0	1-4.3	0.02	2.5	1-5.0	0.06
Cramping	5.0	1-9.0	1.0	1-1.3	0.01	2.0	1-3.0	0.01
Pins & Needles	2.4	1-5.0	1.4	1-2.0	0.09	1.7	1-2.0	0.13
Burning feeling	3.0	1-5.3	1.0	1-1.0	0.00	2.4	1-3.5	0.07
Skin dryness	5.0	1-7.0	2.7	1-5.0	0.03	2.6	1-4.5	0.04
Limb size	6.0	4-7.3	4.5	2.3-6	0.00	3.0	2-6.0	0.01

*based upon a 0 - 10 scale where 0 = no problem and 10 = worse imaginable problem

**p values represent initial value v's 1 month follow up value

Body Composition Change:

There was a statistically significant weight reduction at the end of three weeks of treatment (median 1.49kg's; $p = 0.02$; figure 4.2.2), with this loss being maintained and statistically significant at the 1 month follow up. Body fat also showed a statistically significant reduction at the end of three weeks (median 1.02kg's, $p = 0.015$), but not at 1 month follow up. There were also changes in other body parameters such as percentage body fat, body mass index, truncal and whole body extracellular fluids at the end of the three weeks of treatment (table 4.2.2), but these were not statistically significant. At the one month follow up these parameters were not significantly different in comparison to baseline.

Figure 4.2.2. Changes in weight (Kg's) over three weeks of treatment with the Aerobic Exerciser then at 1 month follow up, as measured by bioimpedance

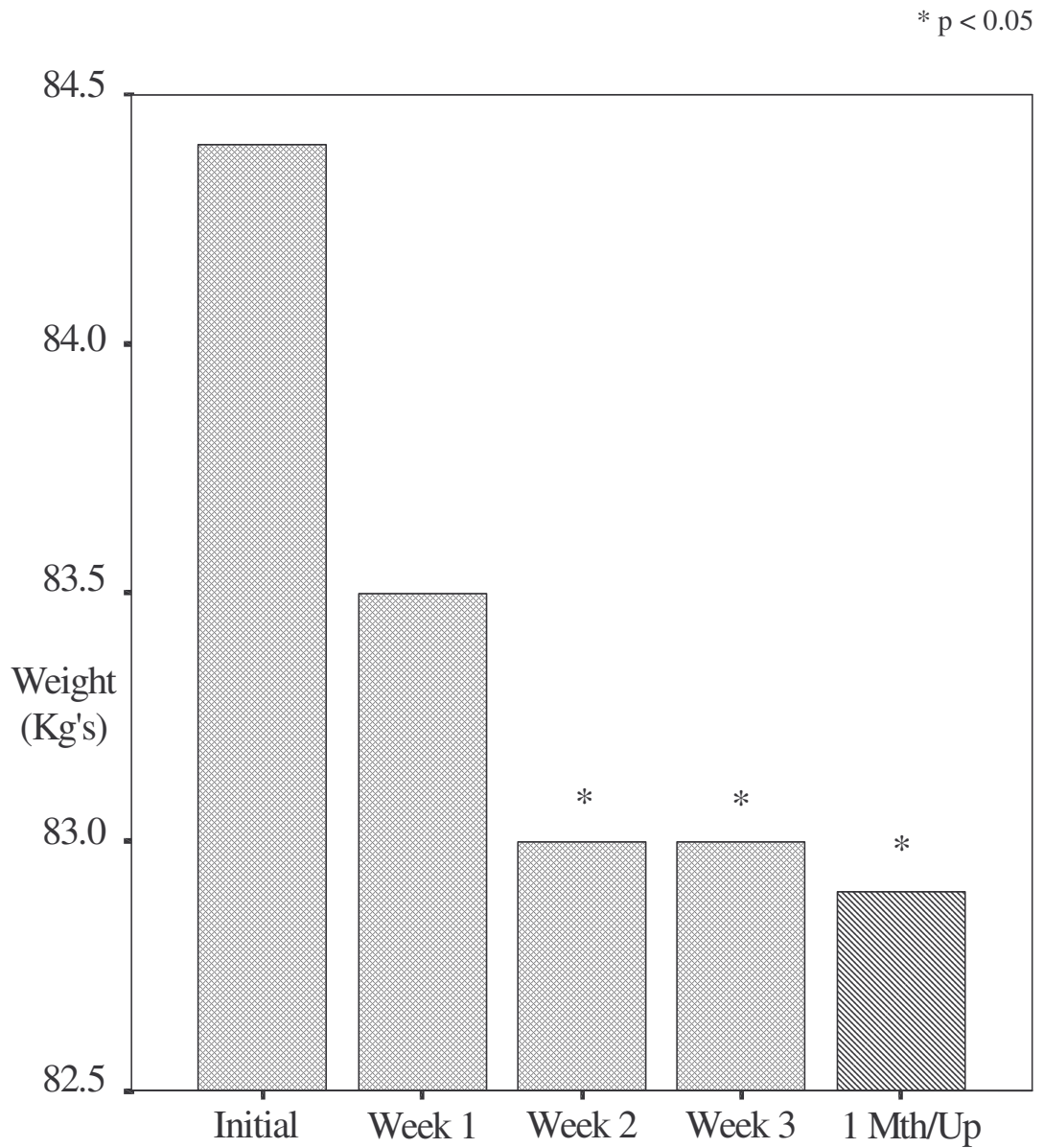

	Initial	End 3 wks	1mth/up
Percentile 25 th	70.4kgs	69.5kgs	69.6kgs
75 th	106.9kgs	105.1kgs	103.2kgs

Table 4.2.2. Changes in body composition at the end of three weeks of treatment with the Aerobic Exerciser then at 1 month follow up, as measured by bioimpedance

Composition	Initial	Final	Change	p =	1mth f/up	Change	p =
Body Fat (Kg's)	35.58	34.56	- 1.02	0.015	33.56	- 1.00	0.420
Percentage Fat (%)	37.60	36.60	- 1.00	0.067	36.90	+ 0.30	0.728
Body Mass Index (kg/m ²)	33.35	33.25	- 0.10	0.216	33.40	+ 0.15	0.401
Whole Body ECF (L's)	12.60	12.20	- 0.40	0.271	11.90	- 0.30	0.836
Trunk Fluid (L's)	16.90	16.30	-0.60	0.267	16.10	- 0.20	0.192

Quality of Life:

The quality of life questionnaire administered after three weeks of treatment demonstrated that there had been many substantial improvements in the participants' quality of life and activities of daily living (Table 4.2.3a). In particular, there were statistically significant improvements in the participants' ability to drive a car ($p = 0.014$), ability to undertake recreational activities ($p = 0.05$), sleeping pattern ($p = 0.001$), feeling of control over the condition ($p = 0.002$) and depression associated with the condition ($p = 0.027$). Some of these improvements significantly correlated with the improvements in subjective leg symptoms, including pain, tightness and heaviness (table 4.2.3b).

Table 4.2.3a. Improvements in certain quality of life domains after three weeks of treatment with the Aerobic Exerciser

Parameter	Pre	Post	% Improvem^t	p =
Difficulty Driving Car*	3.4 (± 3.4)	1.4 (± 1.1)	41.2%	0.014
Difficulty Sleeping	4.3 (± 3.2)	2.7 (± 2.8)	62.8%	0.001
Impact on Recreation	3.7 (± 3.2)	1.9 (± 2.4)	51.3%	0.053
Depression	3.6 (± 2.9)	2.5 (± 2.0)	69.3%	0.027
Treatment Satisfaction	6.1 (± 3.0)	8.6 (± 1.3)	70.9%	0.011
Control Over Condition	3.8 (± 3.3)	6.3 (± 3.3)	60.3%	0.002

* For those who drove a car (n = 17)

Table 4.2.3b. Correlations in quality of life improvements with subjective leg symptom improvements after 3 weeks of treatment with the Aerobic Exerciser

Correlations	r	p
Change in ability to sleep v's change in leg pain	0.588	0.003
Change in ability to sleep v's change in leg tightness	0.448	0.032
Change in feeling of control v's change in leg heaviness	0.673	0.012
Change in treatment satisfaction v's change in leg heaviness	0.801	0.001
Change in treatment satisfaction v's change in leg tightness	0.809	0.001

Side Effects

The most commonly reported side effects were knee pain (11%), dizziness immediately after treatment session (9%) and neck pain (9%). A small percentage (5%) of the participants found the ankle mouldings to be uncomfortable on their legs. As with trial one, the neck and knee pain occurred in those who had pre-existing arthritis and was eliminated by putting a pillow under these areas to give support whilst using the Aerobic Exerciser. Sheep skin ankle protectors that padded the lower legs alleviated leg discomfort caused by the mouldings.

Discussion

This group experienced a statistically significant reduction in median affected leg volume and fluid over the three week treatment period. The fact that the leg volume reduction (as measured by perometry) was less than the leg fluid reduction (as measured by bioimpedance) was perhaps due to the different measuring techniques, which are closely but not perfectly correlated (Moseley, Pille & Carati 2002). With the volume and fluid reductions there were also statistically significant improvements in perceived subjective leg symptoms.

In conjunction with the significant reductions in leg swelling and symptoms, there was also statistically significant reductions in body weight and fat mass. The changes in body composition may indicate that the Sun Ancon[®] Chi Machine[®] Aerobic Exerciser has a systemic effect, or alternatively, it may improve patient mobility and activity, helping them to better control their weight and fat composition. There were also reductions in other body parameters such as percentage body fat, body mass index, trunk and whole body extracellular fluids, however these were not statistically significant. These reduction trends suggest that a longer study period may have shown significant reductions in these parameters as well.

The improvements in leg volume and subjective leg symptoms also positively impacted upon the participants' quality of life and ability to perform activities of daily living. In particular, participants' self reported (and rated) statistically significant improvements in mobility (making it easier to drive and undertake recreational activities), sleeping and a decrease in depression associated with their condition.

Notably, at the 1 month follow up the majority of improvements derived from the use of the Sun Ancon[®] Chi Machine[®] Aerobic Exerciser had been maintained. This was the case for leg fluid volume, weight, and subjective symptoms such as cramping, skin dryness and perceived leg size. When parameters did increase they did so slightly, with no values returning to the original pre-treatment levels. The maintenance of these improvements may perhaps be due to participants feeling more positive about their condition after the trial and therefore being more active. It may also indicate that the Sun Ancon[®] Chi Machine[®] Aerobic Exerciser has sustained benefits of at least 1 month.

This trial demonstrates that the passive exercise and elevation that the Sun Ancon[®] Chi Machine[®] Aerobic Exerciser delivers to the legs results in a reduction in swelling and symptoms as well as improvements in body composition (such as weight and body fat) and well being. These results are particularly important for those patients who due to weight, severely swollen legs, age or co-morbidities can not undertake more active forms of exercise.

TRIAL THREE

The effect of gentle arm exercise combined with deep breathing on secondary arm lymphoedema

Moseley, A., Piller, N. & Carati, C., 2005, 'The effect of gentle arm exercise and deep breathing on secondary arm lymphoedema', Lymphology, vol. 38, no. 3, 136-145.

Abstract

This trial explored the benefits of gentle arm exercise combined with deep breathing for the management of arm lymphedema secondary to breast cancer treatment. Thirty eight women participated in 10 minutes of standardized arm exercise and deep breathing and were assessed every 10 minutes for 1 hour, then 24 hours and 1 week post regime. A cohort of 24 women continued the 10 minute exercise regime morning and evening for 1 month, with assessment being repeated at the end of this time. A group of women (n = 28) who had received no intervention and who had previously been monitored over a 1 month period were used as a comparison control group. Directly after performing the regime there was a reduction in arm volume of 52mls (5.8% actual oedema; $p = 0.004$), with a reduction being maintained at 30 minutes (50mls; $p = 0.006$; 5.3%), 24 hours (46mls; $p = 0.04$; 4.3%) and 1 week (33mls; $p = 0.03$; 3.5%). Reported arm heaviness and tightness also decreased directly after the regimen ($p = 0.05, 0.02$, respectively) and at 24 hours ($p = 0.00, 0.01$ respectively). After 1 month of exercise, arm volume was reduced by 101mls ($p = 0.07$; 9%), perceived limb size and heaviness were significantly reduced ($p = 0.00, 0.02$ respectively) and there was a significant improvement ($p = 0.018$) in the anterior thorax tonometry reading. These results were significant in comparison to the control group which remained relatively unchanged. In conclusion, combined arm exercise and deep breathing significantly reduces arm volume and improves subjective symptoms both initially and when performed over a 1 month period.

Aim

Arm lymphoedema secondary to breast cancer treatment is chronic in nature and without some form of intervention will generally worsen over time (Pecking 1998; Casley-Smith & Casley-Smith 1994), therefore women with this condition need to be vigilant in limb maintenance. Currently there are few easy to implement self management regimes which help women to have control over their limb. Therefore, this study investigated the benefits of gentle arm exercise in combination with deep breathing for secondary arm lymphoedema, as both limb exercise (through lymph node and muscle mobilization) and deep breathing (through changes in intra-thoracic pressure) have been separately shown to improve lymphatic drainage (Földi, Földi & Kubrik 2003; Havas et al 1997; Olszewski 1991, Casley-Smith 1983; Shields 1980).

Treatment Regime

An initial 10 minute regime of combined arm exercise and deep breathing was undertaken. The exercise begins with the hands pointing into the sternum. The arms are then slowly opened and moved outwards until they reach full extension whilst the person takes a deep breath in. When the arms reach full extension all the arm muscles are tightened and the breath held in. The person then relaxes the arm muscles, moves the arms back towards the starting position whilst breathing out (refer to figure 4.3.1). Each participant performed 5 exercises combined with deep breathing followed by a 1 minute rest, and undertook 5 x 5 cycles of exercise plus breathing over the 10 minute period (or 25 exercises in total).

After the 1 week follow up measurement, a cohort of 24 women continued the 10 minute exercise regime morning and evening for 1 month. Participants were required to fill in a log book which recorded how many times they performed the regime over the month so compliance could be monitored. Another group of women with secondary arm lymphoedema (n = 28) who had received no intervention and who had previously been measured before and after a 1 month period were used as a comparison control group.

Figure 4.3.1. Sequence of arm exercise plus deep breathing performed over 10 minutes.

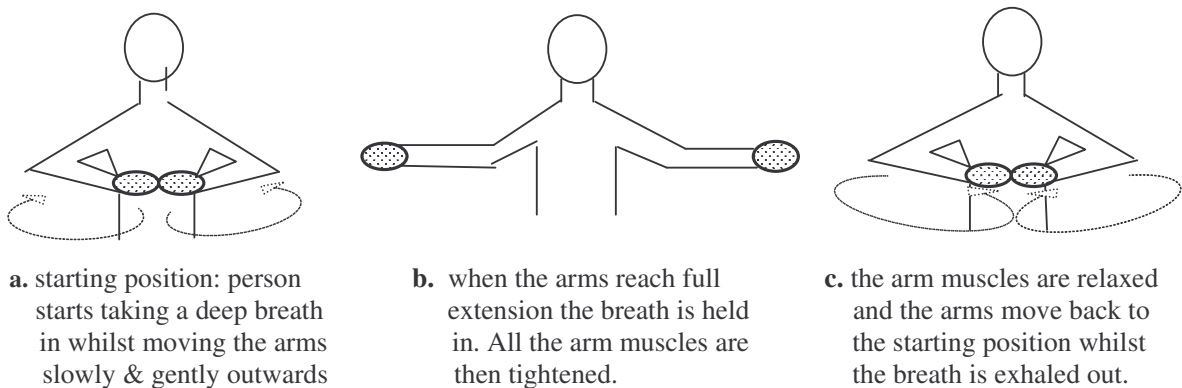

Measurement Schedule

Participants were measured immediately prior to commencing the regime (baseline), directly after performing the regime and then every 10 minutes for 1 hour, then at 24 hours and 1 week post exercise. The cohort who continued the regime at home had measurements taken at the beginning and end of the 1 month period.

Analysis

All data were analysed using SPSS (version 12.0). As lymphoedema arm volume was not normally distributed at baseline, two related samples non-parametric Wilcoxon tests (Monte Carlo 99%) were used to analyse the changes in arm volume. Arm volume results are presented as median values with the 25th and 75th percentiles. Subjective symptoms were analysed using the student paired sample t-test, where $p < 0.05$ is statistically significant. The correlation between those who responded directly after the exercise regime and those who responded after one month of performing the regime was determined using the Pearson Correlation Coefficient.

Study Population

Originally 40 women were recruited in to the exercise group, but two were subsequently removed from analysis due to one participant no longer having a significant lymphoedema (volume difference $< 200\text{mls}$) and the other having extremely fluctuating volumes (beyond what would normally be expected). The remaining thirty eight women were aged 37-77yrs (mean $61 \pm 9.5\text{yrs}$) with unilateral secondary arm lymphoedema. Twenty had had a total mastectomy, whilst 18 had had a partial mastectomy. All women had undergone axillary lymph node clearance, with 76% receiving adjunct radiotherapy. Lymphoedema duration varied, with 48% having had it for 1-5 years, 21% for 6-10 years and 31% for greater than 10 years. Table 4.3.1 presents the demographic details of the women who were involved in the 1 month exercise and deep breathing program and the women in the comparison control group.

Table 4.3.1. Demographic details of participants in the 1 month exercise plus deep breathing (EDB) group and the 1 month control group^a

	EDB	CONTROL
Number	24	28
Age (yrs)	60.1 ± 1.6 (42 – 76)	65 ± 2.0 (42 – 87)
Type of Surgery (%)		
Partial mastectomy + axillary clearance	58.3	42.9
Total mastectomy + axillary clearance	41.7	57.1
Received Radiotherapy (%)	79.2	92.9
Received Chemotherapy (%)	33.3	46.4
Time since onset of LO (yrs)	5.5 ± 0.9 (1 – 15)	3.5 ± 0.7 (0.5 – 15)
Baseline limb volume (mls)	2873 (2118 – 3672)	3278 (2848 – 3916)

a. means plus standard errors, arm volume presented as medians plus 25th & 75th percentiles.

Results

Arm Volume Changes:

Directly after performing the 10 minute exercise regime, there was a median reduction in arm volume of 52mls ($p = 0.004$; Figure 4.3.2), this represents a percentage reduction in actual oedema of 5.8%. A volume reduction was sustained at the 30 minute point (50mls, $p = 0.006$, 5.3%) but after this time the fluid gradually returned and by 60 minutes the median volume had returned to the baseline value. Interestingly, although participants were instructed not to perform the exercise during the 24 hour and 1 week follow up periods, there were volume reductions at these follow up measurements of 46mls ($p = 0.04$, 4.3%) and 33mls ($p = 0.03$, 3.5%) respectively.

Tonometry Changes:

Tonometry readings taken at the forearm, upper arm and anterior thorax territories did not change significantly at the 60 minute point, 24 hour or 1 week follow up in the exercise group.

Figure 4.3.2. Median arm volume and percentage oedema reduction at various periods after performing the exercise plus deep breathing regime

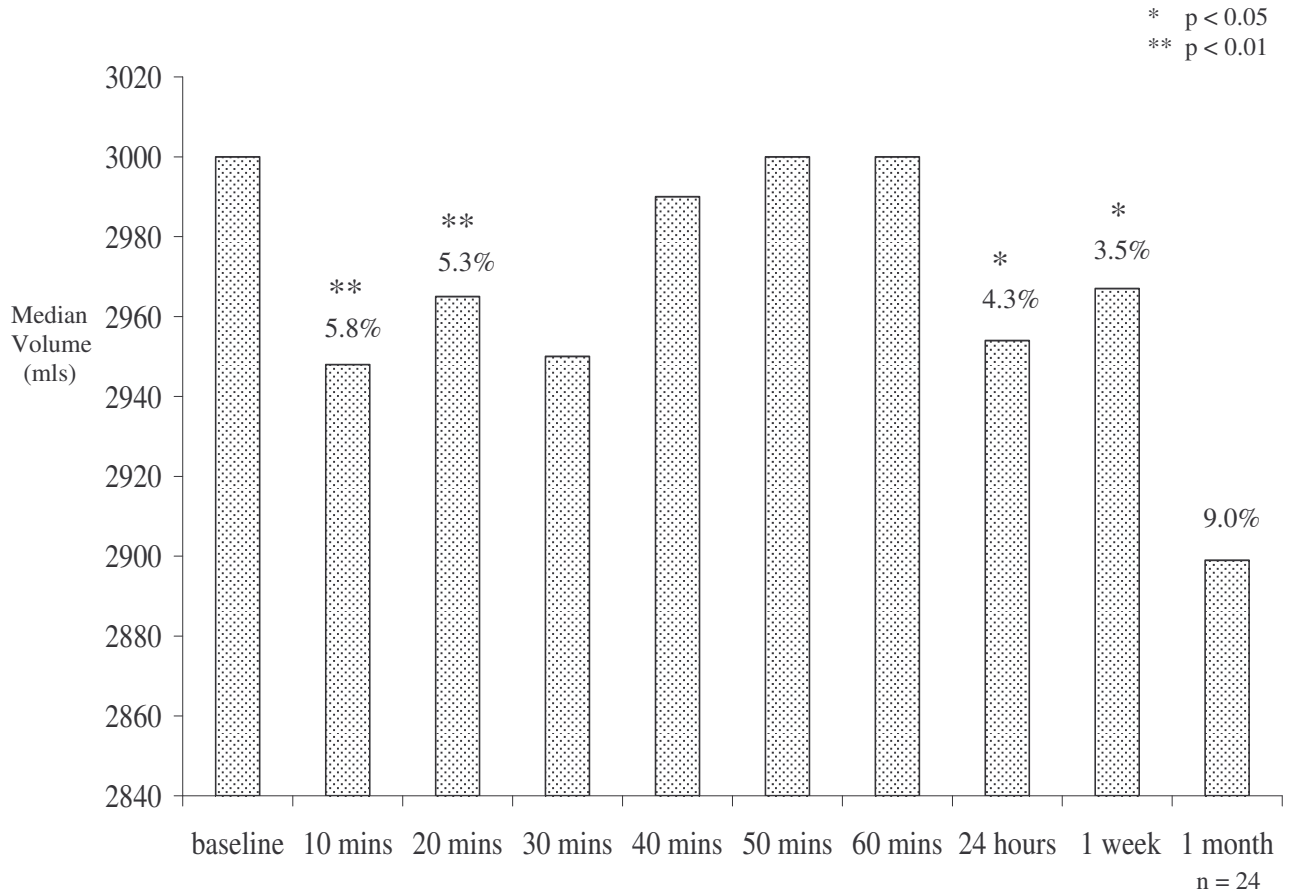

	Baseline	10 mins	30 mins	24 hrs	1 wk	1mth
25 th Percentile	2216	2168	2203	2180	2215	2062
75 th Percentile	3656	3705	3624	3669	3655	3610

Subjective Arm Symptoms Changes:

Symptoms such as pain, burning feelings and limb temperature were only rated as being slightly problematic and changed little through out the trial period (Table 4.3.2). Reported arm heaviness and tightness decreased directly after the exercise regime ($p = 0.05$; 0.02 , respectively), with the reduction in tightness being sustained at 24 hours ($p = 0.00$). The reduction in heaviness was sustained at 24 hours ($p = 0.01$) and 1 week ($p = 0.01$). Reported sensations of pins & needles were significantly reduced at 24 hours ($p = 0.03$) and 1 week ($p = 0.03$), whilst perceived limb size was significantly reduced at 1 week ($p = 0.04$).

Table 4.3.2. Change in subjective arm symptoms at various periods after performing the exercise plus deep breathing regime*

Symptom	B	Tx	p =	S.E.	24hrs	p =	S.E.	1wk	p =	S.E
Pain	0.9	0.8	0.32	0.04	1.03	0.52	0.28	0.71	0.49	0.21
Tightness	1.9	1.7	0.02*	0.06	1.23	0.00*	0.19	1.73	0.67	0.37
Heaviness	4.0	3.8	0.05*	0.09	3.00	0.01*	0.17	3.03	0.01*	0.37
P & N's	1.3	1.3	1.00	0.34	0.56	0.03*	0.34	0.68	0.03*	0.32
Burning	0.6	0.4	0.19	0.14	0.53	0.68	0.22	0.16	0.18	0.33
Limb temp	1.5	1.5	0.32	0.03	1.58	0.94	0.33	1.20	0.25	0.30
Limb Size	5.5	5.4	0.32	0.79	4.99	0.08	0.29	4.99	0.04*	0.25

* based upon a 0 - 10 scale, where 0 = no problem and 10 = worse imaginable problem

P&N's = Pins & needles

B = Baseline

Tx = Directly after exercise regime

24hrs = 24 hour follow up

1wk = 1 week follow up

1 Month Follow Up:

In the continuing cohort of twenty four women, after one month of the exercise regime, the median arm volume reduction was 101mls ($p = 0.07$; Figure 4.3.2) which represents a percentage reduction of 9%. This is in comparison with the control group which remained relatively unchanged, having only had a reduction of 7mls ($p = 0.975$; table 4.3.3). The correlation between those who responded directly after the exercise regime (in terms of arm volume reduction) and those who responded after 1 month of performing the regime was strong and statistically significant ($r = 0.551$; $p = 0.005$; figure 4.3.3).

At the end of the one month program there was an improvement in the tonometry measurement taken on the anterior thorax lymphatic territory ($p = 0.018$; table 4.3.3). This improvement was also statistically significant in comparison to the control group ($p = 0.005$; table 4.3.3), who experienced a deterioration in this measurement, indicating a progression in fibrotic induration. In particular, in the exercise group there were 12 participants who had considerable fibrotic induration in the anterior thorax and who significantly improved at the 1 month measurement ($p = 0.00$).

The exercise group also experienced statistically significant reductions in reported arm heaviness and perceived limb size after the 1 month regime ($p = 0.00$ and 0.02 respectively; table 4.3.3). These reductions were also statistically significant in comparison to the control group (0.044 and 0.016 respectively; table 4.3.3), with the control group's subjective symptoms remaining relatively unchanged over this time period.

Figure 4.3.3. Correlation of median arm volume reduction directly after performing the exercise regime with median arm volume reduction after 1 month of performing the exercise regime (n = 24).

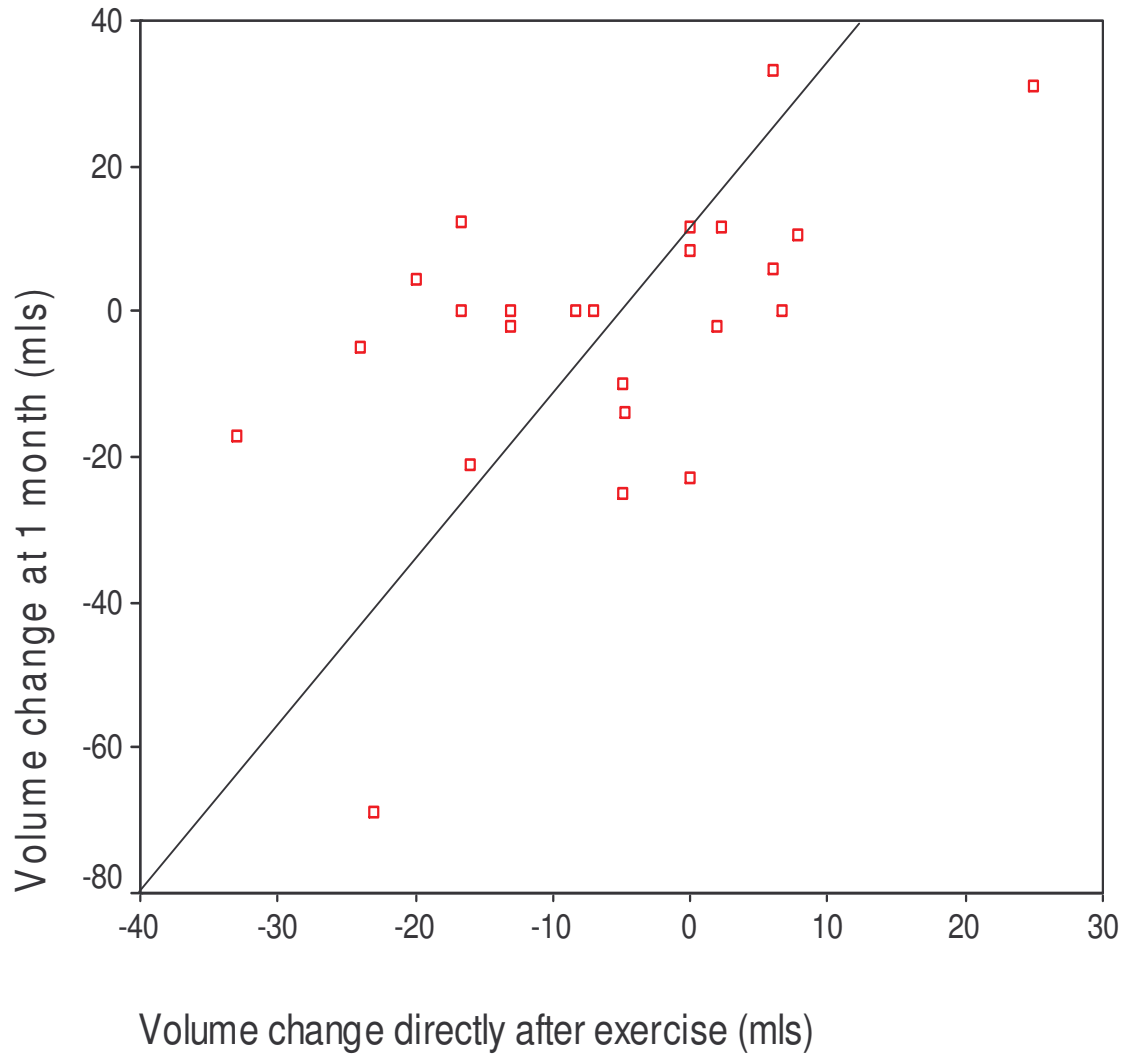

Table 4.3.3. Change in parameters in the deep breathing plus exercise (EDB) group and the Control (CO) group at the end of 1 month^a.

Parameter	EDB			CO		EDB v's CO	
	Baseline	1 month	p	Baseline	1 month	p	p
Arm Volume	2873 (2118-3612)	2772 (2062-3610)	0.070	3278 (2848-3916)	3271 (2829-3959)	0.975	0.211
Ton Forearm	4.8 ± 0.2	5.1 ± 0.2	0.163	4.7 ± 0.2	5.1 ± 0.2	0.141	0.392
Ton Upper Arm	6.0 ± 0.3	6.0 ± 0.2	0.778	6.6 ± 0.3	6.7 ± 0.3	0.565	0.120
Ton Ant Thorax	7.3 ± 0.2	8.3 ± 0.4	0.018*	6.9 ± 0.4	6.5 ± 0.4	0.102	0.005*
Pain	0.9 ± 0.1	0.5 ± 0.3	0.870	2.6 ± 0.3	2.9 ± 0.4	0.204	0.309
Heaviness	4.0 ± 0.1	2.6 ± 0.4	0.020*	4.6 ± 0.5	4.5 ± 0.6	0.803	0.044*
Tightness	1.9 ± 0.1	1.6 ± 0.5	0.970	3.3 ± 0.5	3.1 ± 0.5	0.624	0.789
Pins & Needles	1.3 ± 0.3	0.5 ± 0.3	0.120	2.4 ± 0.5	2.5 ± 0.5	0.720	0.194
Burning	0.6 ± 0.1	0.6 ± 0.3	0.750	1.4 ± 0.3	1.4 ± 0.3	1.000	0.861
Limb Temp	1.5 ± 0.1	1.4 ± 0.5	0.480	2.1 ± 0.3	2.4 ± 0.4	0.348	0.235
Limb Size	5.5 ± 0.8	4.8 ± 0.2	0.000*	5.5 ± 0.4	5.1 ± 0.4	0.210	0.016*

a. means plus standard errors, arm volume presented as medians plus 25th & 75th percentiles.

Ton = Tonometry

Adverse Effects & Compliance

The standardized arm exercise plus deep breathing was well tolerated with no reported adverse effects. The smaller sample size in the group who undertook the exercise regime for one month (n = 24) was due to participants being unable to complete the one month exercise period because of sickness or personal reasons. There was an overall 90% compliance rate in the group who performed the exercise and deep breathing regime over the 1 month period. The remaining 10% only missed a few of the 10 minute sessions through out the month.

Discussion

This trial demonstrated that arm volume and percentage oedema is significantly reduced immediately after performing 10 minutes of standardized deep breathing and arm exercise and that this reduction is sustained for at least 30 minutes after exercise cessation. The reductions observed at the 24 hour and 1 week follow up may be related to participants continuing the exercise at home (even though they were instructed not to).

It also shows that this form of exercise does not increase fluids in the interstitium, or exacerbate the lymphoedema. This supports evidence that women with post mastectomy lymphoedema can undertake some forms of limb exercise without exacerbating their condition. For example, a pilot study by McKenzie & Kalda (2003) that involved 7 women who undertook two months of aerobic and resistance training found that there was no statistical increase in arm volume or circumference. However, unlike this trial, there was no statistical reduction in these parameters either.

Accompanying the arm volume reductions were reductions in reported arm heaviness and tightness directly after performing the regime and at 24 hours. At the 1 week follow up, heaviness, pins & needles and perceived limb size were statistically reduced. These reductions were important, as sensations of heaviness and tightness were reported to be particularly problematic for this group of women.

The group who performed the exercise and deep breathing regime over one month demonstrated a median reduction in arm volume of 101mls and in percentage oedema of 9%, with this reduction being close to statistical significance ($p = 0.07$). The reduction of 9% after 1 month is noteworthy as other studies have shown that compression worn over a 2-4 week period generally results in a reduction in the range of 4-7% (Johansson et al 1998; Swedborg 1984). This demonstrates that this regime maybe a viable alternative to wearing compression sleeves, which some women report as being unsightly and uncomfortable.

The fact that there was a strong correlation between those who experienced an arm volume reduction directly after performing the exercise and deep breathing and those who experienced a reduction after 1 month also gives clinicians a way of determining who will most likely benefit from this type of regime. Those who experience an arm volume reduction after 10 minutes of performing the regime being much more likely to continue to respond over a longer time period.

The 1 month group also experienced statistically significant improvements in arm heaviness and perceived limb size. Also of importance was the statistically significant improvement in tissue hardness in the anterior thorax area. The action of the exercise, which moves the pectoralis major muscle over the underlying structures may have helped to loosen underlying

adhesions and/or fibrosis, improving the general condition of the tissues. This is certainly an effect worth investigating.

The improvements in the group who performed the exercise and deep breathing program over one month were in stark contrast to the comparison control group. In the control group the arm volume, subjective symptoms and tonometry readings remained relatively unchanged or in some cases, even got worse. This is consistent with a study by Szuba et al (2003) which described the progression of a group of patients who received decongestive lymphatic therapy (DLT) followed by maintenance treatment (daily self-massage and compression garments). These patients had a mean increase in limb volume of 32.7mls one month after DLT, and a further increase of 35mls after six months. Therefore, the longer term reductions over 1 month of exercise, in comparison with the control group, demonstrate that this regime can play a key role in the maintenance of secondary arm lymphoedema.

Combined deep breathing and gentle arm exercise represents an easy to implement and cost effective regime that can be utilised by women with secondary lymphoedema in the home environment. The effect of concentrated arm exercises alone is investigated in the following pilot study (trial four). The results from this study also suggest that other forms of exercise that incorporate deep breathing and arm exercise, such as Tai Chi and Qi Gong may also be beneficial for secondary arm lymphoedema sufferers. The use of such exercises should, however, be carefully monitored by the patient's health professional.

TRIAL FOUR

The effect of instructed limb exercise for those with secondary arm or leg lymphoedema

Buckley, G., Piller, N. & Moseley, A., Mar 2004, 'Can exercise improve lymphatic flow? A pilot trial of the objective measurement of fluid movement in subjects with mild secondary lymphoedema', 5th Australasian Lymphology Association Conference Proceedings, 37 – 42.

Abstract

This pilot study investigated the benefits of an instructed exercise regime for arm and leg lymphoedema secondary to cancer treatment. Fourteen participants, 7 with arm and 7 with leg lymphoedema participated in a 30 minute regime which started with deep breathing followed by self massage to the areas adjacent to the swollen limb then 20 minutes of proximal to distal sequential limb exercises. Measurements, including limb volume, fluid, subjective symptoms and range of movement were taken at baseline, directly after the regime and 20 minutes post regime. Results showed a transient increase in mean arm fluid of 12mls (0.4% oedema) directly after the regime which did not persist at 20 minutes. Those with leg lymphoedema experienced a mean leg fluid reduction of 100mls (10.4% oedema) which persisted at 20 minutes post regime and a mean leg volume reduction of 58mls (5.5% oedema). Both groups experienced reductions in truncal fluid (100mls), subjective symptoms such as heaviness and tightness plus improvements in limb range of movement. This study demonstrates that this particular regime maybe more suited to those with leg lymphoedema in terms of fluid and volume reduction, but that other benefits such as improved subjective symptoms and limb range of movement can be derived.

Aim

This pilot study investigated the benefits of an instructed deep breathing, self massage plus distal to proximal sequential exercise regime in secondary arm and leg lymphoedema. This regime has been employed by, and extensively written about by Casley-Smith & Casley-Smith (1997), and modified versions are often taught to patients by clinicians in isolation or as part of an overall treatment regime. The theory is that the self massage will help to drain the area adjacent to the swollen limb creating a reservoir for the fluid moved by the exercise to drain into. However, the stand alone efficacy of such a regime has not, to date, been formally investigated.

Treatment Regime

Participants with secondary arm or leg lymphoedema related to previous cancer treatment were involved in the trial. The 30 minute regime was instructed by a physiotherapist and started with deep breathing (5 minutes) and then self-massage of the area and lymph nodes adjacent to the swollen limb (5 minutes) followed by 20 minutes of limb exercises. The limb exercise were specific for either upper or lower limbs as outlined by Casley-Smith & Casley-Smith (1997) and followed the recommendation for lymphoedema management in that they were sequential, proximal to distal, gentle and performed slowly (refer to appendix 4.4.1 and 4.4.2 for a detailed description of the regime undertaken by the arm and leg lymphoedema participants).

Measurement Schedule

Measurements were taken immediately before commencing the regime (baseline), directly after performing the regime and 20 minutes post regime. Range of movement of the affected limb was measured in this trial with a goniometer.

Analysis

All data were analyzed using SPSS (version 11.5) to determine trends in responses following the instigated regime. Results for the arm and leg groups were analysed separately using paired sample t-tests, where $p < 0.05$ is statistically significant.

Study Population

Fourteen participants undertook the instructed regime, 7 with arm lymphoedema secondary to breast cancer treatment and 7 with leg lymphoedema secondary to either; gastrointestinal, urinary, reproductive or melanoma cancer treatment. Table 4.4.1. represents the profile of these participants.

Table 4.4.1. Profile of arm and leg lymphoedema participants

	Arm Lymphoedema Participants	Leg Lymphoedema Participants
Number	7	7
Age	42-65 years (mean 56.7 ± 8.1yrs)	47-80 years (mean 65.1 ± 15.3yrs)
Surgery	3 (43%) partial mastectomies 4 (57%) total mastectomies	5 (71%) pelvis/abdominal 2 (29%) groin surgeries
Radiotherapy	6 (86%) had radiotherapy	2 (29%) had radiotherapy
Lymphoedema onset	3mths – 2 yrs after surgery	3mths – 10 yrs after surgery
Worse in evening	5 (71.4%)	7 (100%)
Worse in heat	7 (100%)	7 (100%)

Results

Arm Lymphoedema Participants

Arm Volume Changes:

A transient (non-significant) increase of 12mls (\pm 32.1mls), equal to 0.4% oedema was seen in mean arm volume (as measured by perometry) immediately after performing the regime. This did not persist at 20 minutes post regime, with the mean arm volume decreasing by 24mls (\pm 61.0mls), 0.8% oedema (net reduction 12mls, 0.4% oedema) at the 20 minute point (figure 4.4.1). The mean arm fluid (as measured via bioimpedance) also demonstrated an increase trend of 20mls (\pm 29.8mls), 1.0% oedema directly after the regime, with a mean reduction of 12mls (\pm 43.5mls), 0.4% oedema at the 20 minute point (figure 4.4.1).

Truncal Fluid Changes:

There was also a non significant reduction in mean truncal fluid of 100mls (\pm 161.8mls) immediately after the regime, which returned to the pre-exercise baseline value at the 20 minute mark (Figure 4.4.2).

Figure 4.4.1. Mean arm volume and fluid at baseline, directly after performing the instructed exercise regime and 20 minutes post regime

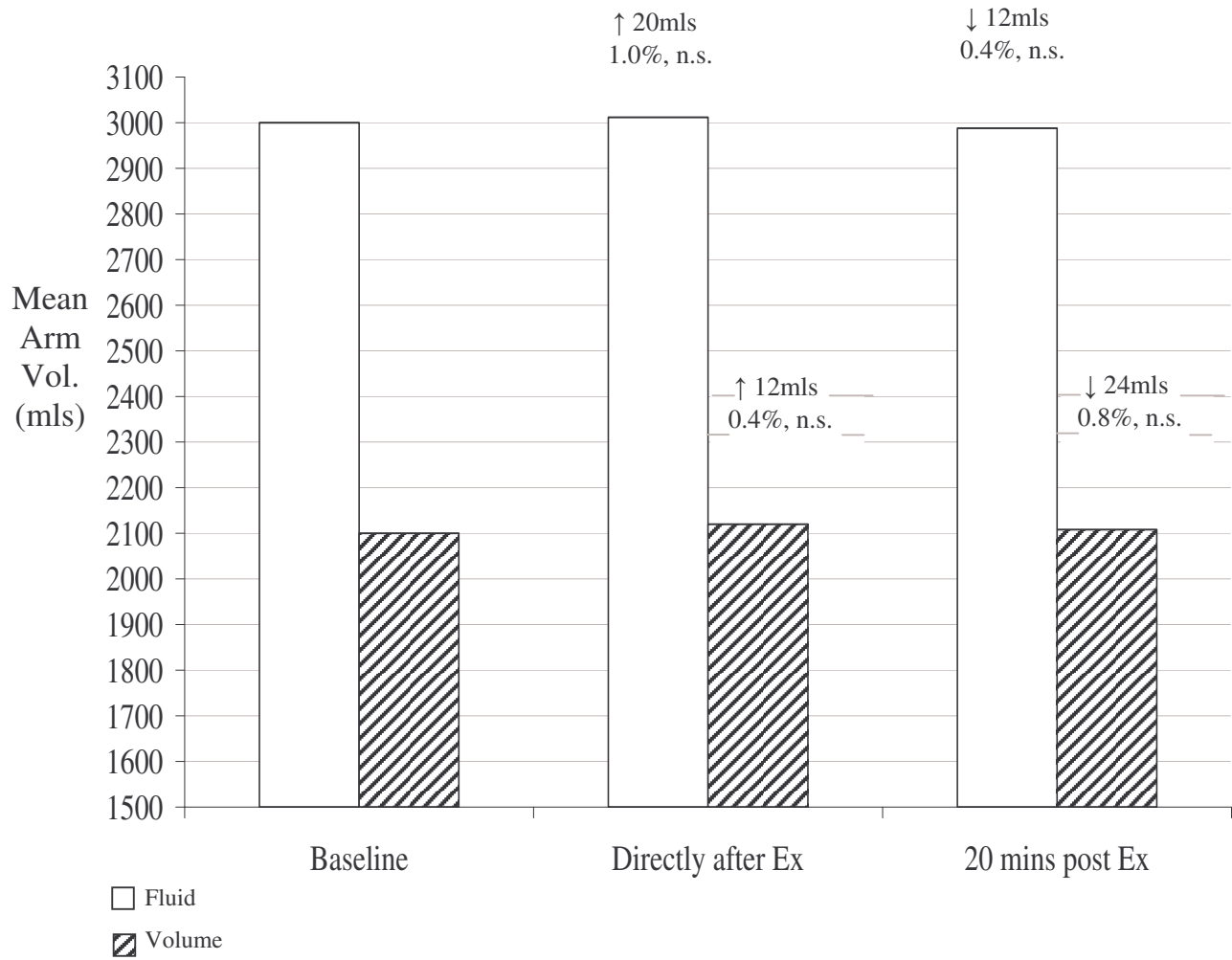
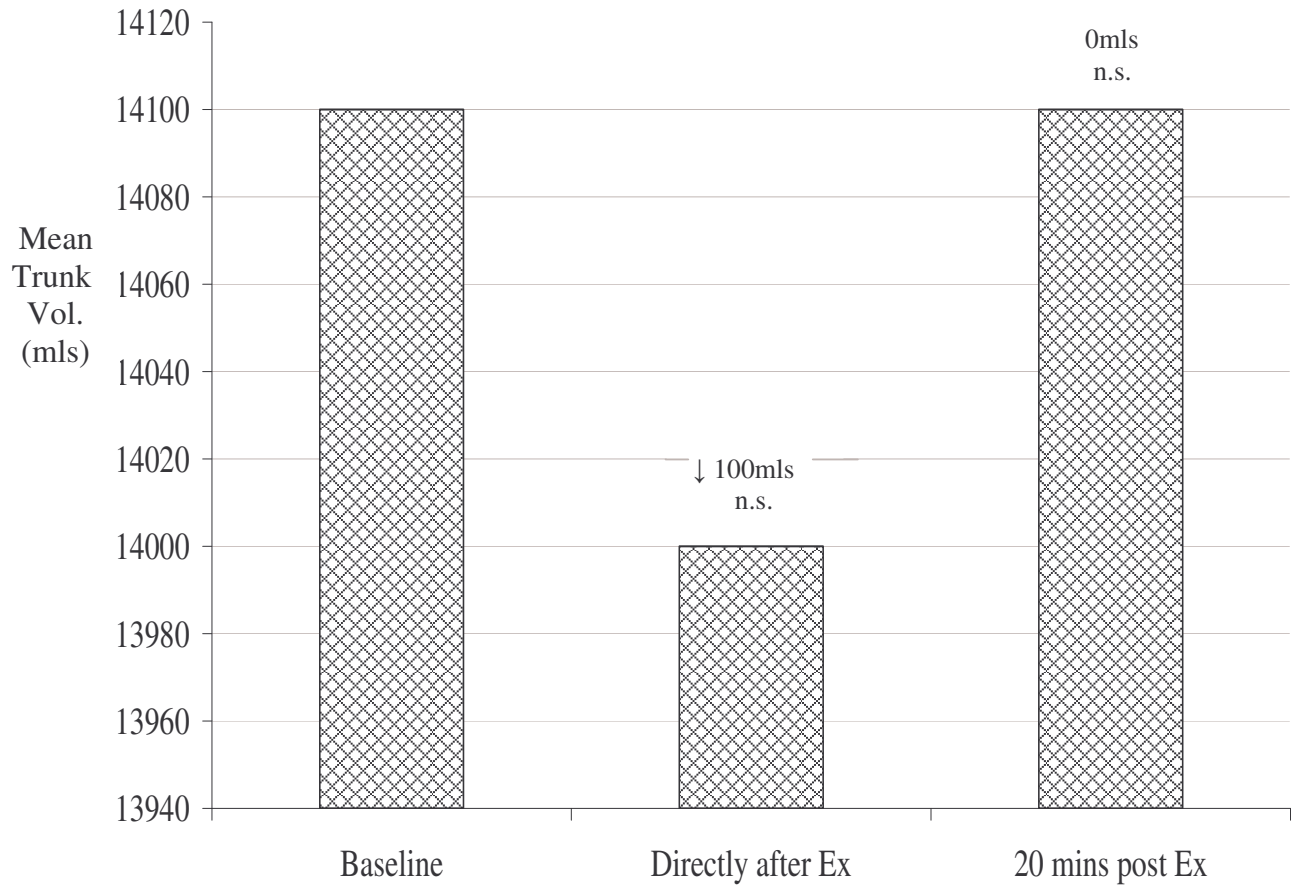

Figure 4.4.2. Mean truncal fluid in the arm lymphoedema group at baseline, directly after performing the instructed exercise regime and 20 minutes post regime



Subjective Arm Symptom and Range of Movement Changes:

Participants reported improvements in subjective arm symptoms after performing the regime, especially with reference to heaviness and tightness (table 4.4.2), with the reduction in tightness being statistically significant ($p = 0.038$). There were moderate reductions in arm temperature difference and arm movement limitation ($p = n.s.$). Arm range of movement also improved (as measured by Goniometer), notably shoulder flexion and external rotation, and elbow and wrist flexion (table 4.4.3), with the improvement in elbow flexion being statistically significant ($p=0.048$).

Table 4.4.2. Mean reductions in arm subjective limb symptoms directly after performing the instructed exercise regime

	Pre	S.E.	Post	S.E.	p =
Heaviness	5.0	1.2	2.4	1.1	0.071
Tightness	4.8	1.2	2.0	0.8	0.038[‡]
Temperature difference	2.9	0.9	0.0	0.0	0.142
Movement limitation	2.0	1.3	1.4	0.9	0.356
Limb size	3.7	0.6	3.6	0.6	0.356

Table 4.4.3. Mean improvements in arm range of movement (degrees^o) directly after performing the instructed exercise regime

	Pre	S.E.	Post	S.E.	p =
Shoulder flexion	162.8	5.3	164.3	4.3	0.522
Shoulder external rotation	84.3	9.3	87.1	5.6	0.418
Elbow flexion	138.4	6.4	142.8	3.9	0.048[‡]
Wrist flexion	60.7	11.7	67.8	6.4	0.140

S.E. = standard error

Leg Lymphoedema Participants

Leg Volume Changes:

A decrease of 100mls (± 111.2 mls), equal to 10.4% oedema in mean leg fluid (as measured by bioimpedance) was detected directly after performing the regime and sustained at 20 minutes post regime (figure 4.4.3). Mean leg volume (as measured by perometer) demonstrated a similar, albeit smaller (55mls ± 62.8 mls; 5.8% oedema) trend in volume reduction.

Truncal Fluid Changes:

A non significant decrease in truncal fluid of 100mls (± 182.6 mls) was also measured immediately following the regime in this group (figure 4.4.4). As with the arm lymphoedema group, the decrease in truncal fluid directly after the regime returned to the pre-regime baseline value when measured 20 minutes post regime.

Figure 4.4.3. Mean leg volume and fluid at baseline, directly after performing the instructed exercise regime and 20 minutes post regime.

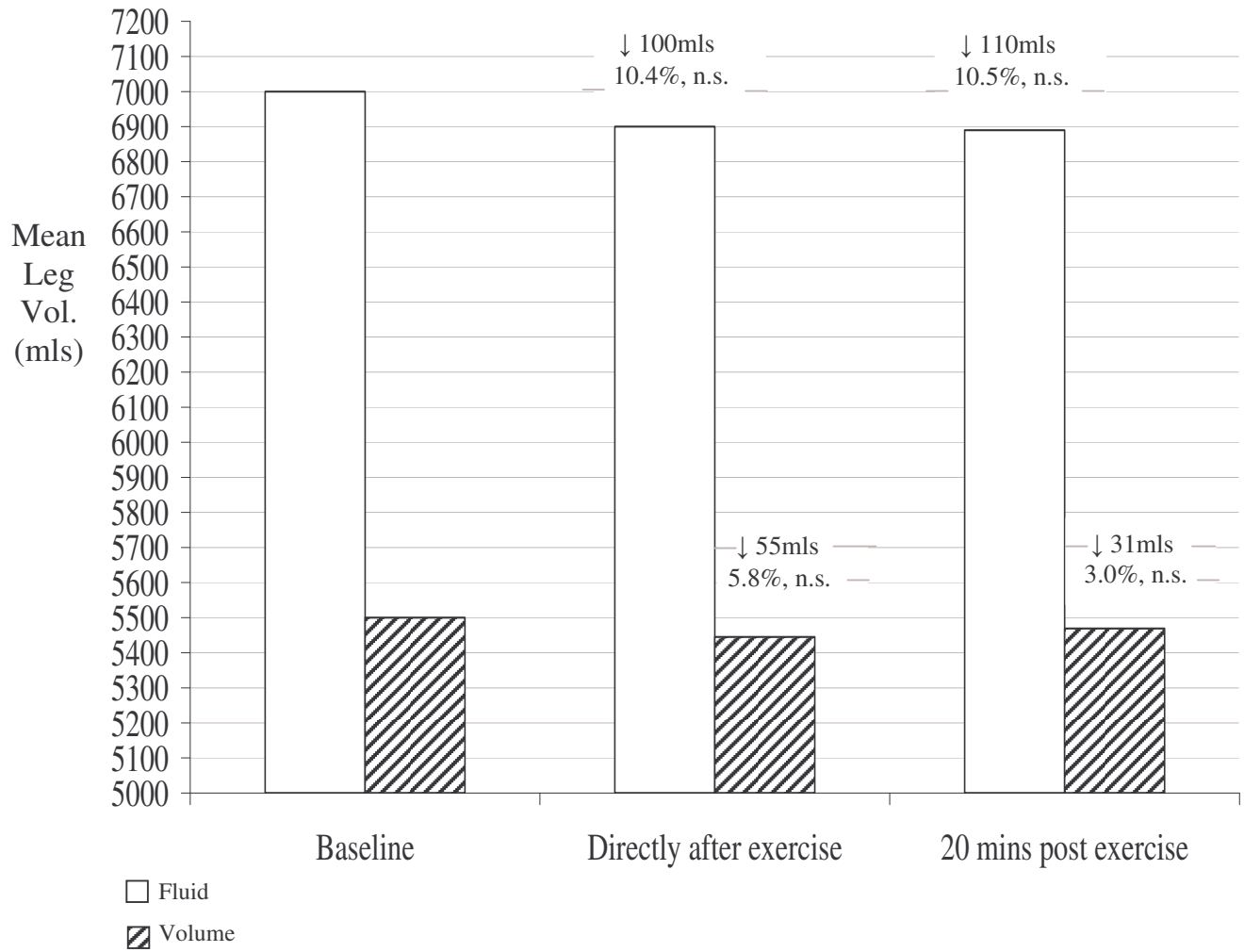
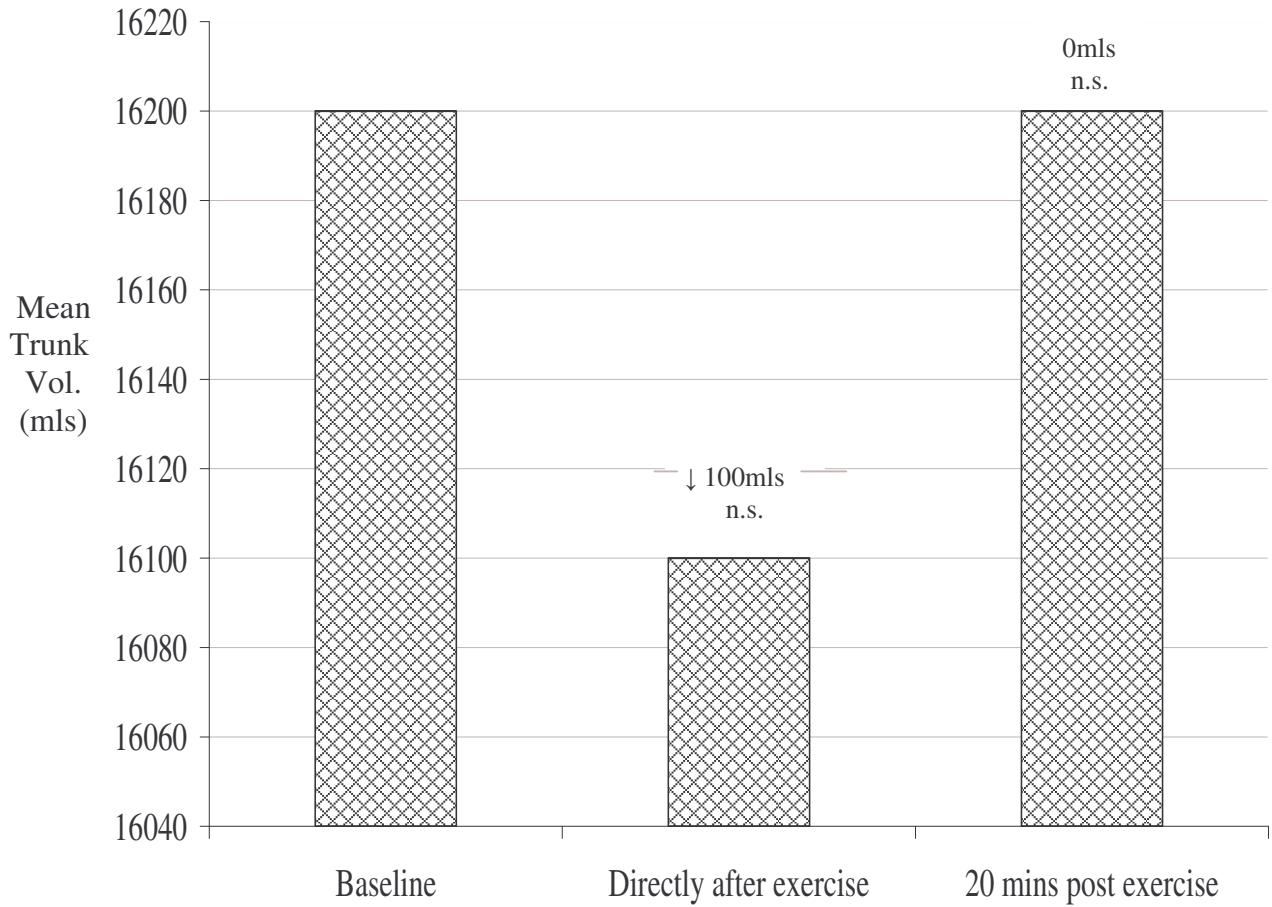

Figure 4.4.4. Mean truncal fluid in the leg lymphoedema group at baseline, directly after performing the instructed exercise regime and 20 minutes post regime



Subjective Leg Symptom and Range of Movement Changes:

In concert with the arm lymphoedema group, this group also experienced improvements in subjective symptoms and limb range of movement. This included subjective leg symptoms such as heaviness and tightness (table 4.4.4), and, to a lesser degree, perceived temperature difference, size difference and movement limitation. Leg range of movement, in terms of hip abduction, knee flexion and ankle dorsiflexion also improved after performing the regime (table 4.4.5).

Table 4.4.4. Mean reductions in leg subjective limb symptoms directly after performing the instructed exercise regime

	Pre	S.E.	Post	S.E.	p =
Heaviness	2.8	1.3	1.0	0.7	0.439
Tightness	1.3	0.9	0.4	0.3	0.142
Temperature difference	1.6	0.6	1.0	0.0	0.231
Movement limitation	0.9	0.5	0.4	0.4	0.356
Limb size	4.7	0.7	4.3	0.7	0.200

Table 4.4.5. Mean improvements in leg range of movement (degrees^o) directly after performing the instructed exercise regime

	Pre	S.E.	Post	S.E.	p =
Hip abduction	27.8	2.3	29.3	5.3	0.356
Knee flexion	138.4	2.4	142.8	1.5	0.618
Ankle dorsiflexion	60.7	4.4	67.8	4.8	0.534

S.E. = standard error

Discussion

This small pilot study has shown that some volume and fluid reduction is to be anticipated when implementing this instructed exercise regime (which, once demonstrated, would be then undertaken in the home environment). In arm lymphoedema this reduction is relatively small, with a net reduction of 12mls (0.4% in oedema) 20 minutes post regime. This reduction being small in comparison to other studies which have investigated exercise, including; resistance training – 2% (McKenzie & Kalda 2003), hydrotherapy – 48mls, 4.8% (Box et al 2004) and deep breathing combined with arm exercise – 52mls, 5.8% (Moseley et al 2005). Those with leg lymphoedema experienced a greater leg fluid reduction of 100mls (10.4%) which was maintained 20 minutes post regime.

Both groups experienced an initial reduction in truncal fluid of 100mls which returned to the baseline value at the 20 minute mark. This reduction is most likely related the deep breathing component of the regime, which can influence both lymphatic and venous return from the lower limbs through changes in intra-thoracic and intra-abdominal pressure (Sumner 1995; Olszewski 1991; Shields 1980). Changes in truncal fluid after deep breathing/exercise were also demonstrated in a study by Moseley et al (2005), with a 31.6ml reduction in truncal fluid after 10 minutes of deep breathing combined with arm exercise. This displays the benefit of deep breathing for those with lymphoedema and that the inclusion of deep breathing into treatment regimes is certainly worthwhile.

Both groups experienced improvements in subjective symptoms, most notably heaviness and tightness, which were the most highly scored problems in both arm and leg lymphoedema. The improvements in limb range of movement are also important, as limb function can be adversely

affected by the type of surgery performed, radiotherapy to the area and the swelling itself. Good limb function is also important for lymphatic drainage, which is reliant on muscle movement to change interstitial pressure (Havas et al 1997).

It would appear from this pilot study that the instructed deep breathing, self massage and sequential exercise regime is more beneficial for leg lymphoedema in terms of limb fluid and volume reductions, with the arm lymphoedema group having very little change in these parameters. However, other benefits such as clearing the thoracic area, reducing limb symptomology and improving limb range of movement can be derived. A larger clinical trial with a larger sample size and conducted over a longer time period is certainly warranted to examine the true benefits of this particular exercise regime.

Comparison graphs of the percentage volume change achieved by the three new exercise regimes in comparison to previously studied exercise regimes

For comparative purposes, the percentage volume changes achieved by the three new exercise regimes and previously studied exercise regimes for arm lymphoedema and lower leg swelling (secondary leg lymphoedema and venous oedema) are presented in figure 5a. and 5b. These two figures present the percentage reduction at trial end and at follow up (if measured). They demonstrate the magnitude of reduction that can be achieved by different exercise regimes (including the three new regimes presented) and whether these reductions are maintained at the follow up period.

Figure 5a. Percentage arm volume change for different exercise regimes in arm lymphoedema; initial (post trial) reduction and follow up reduction

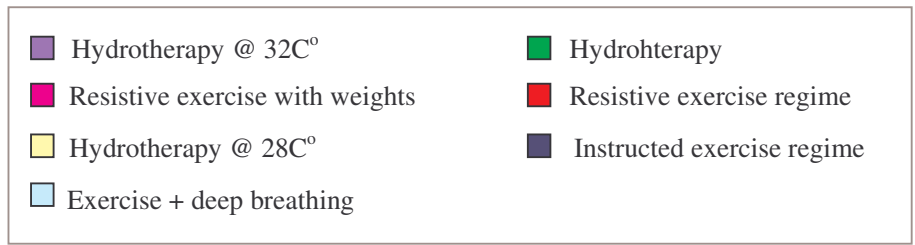
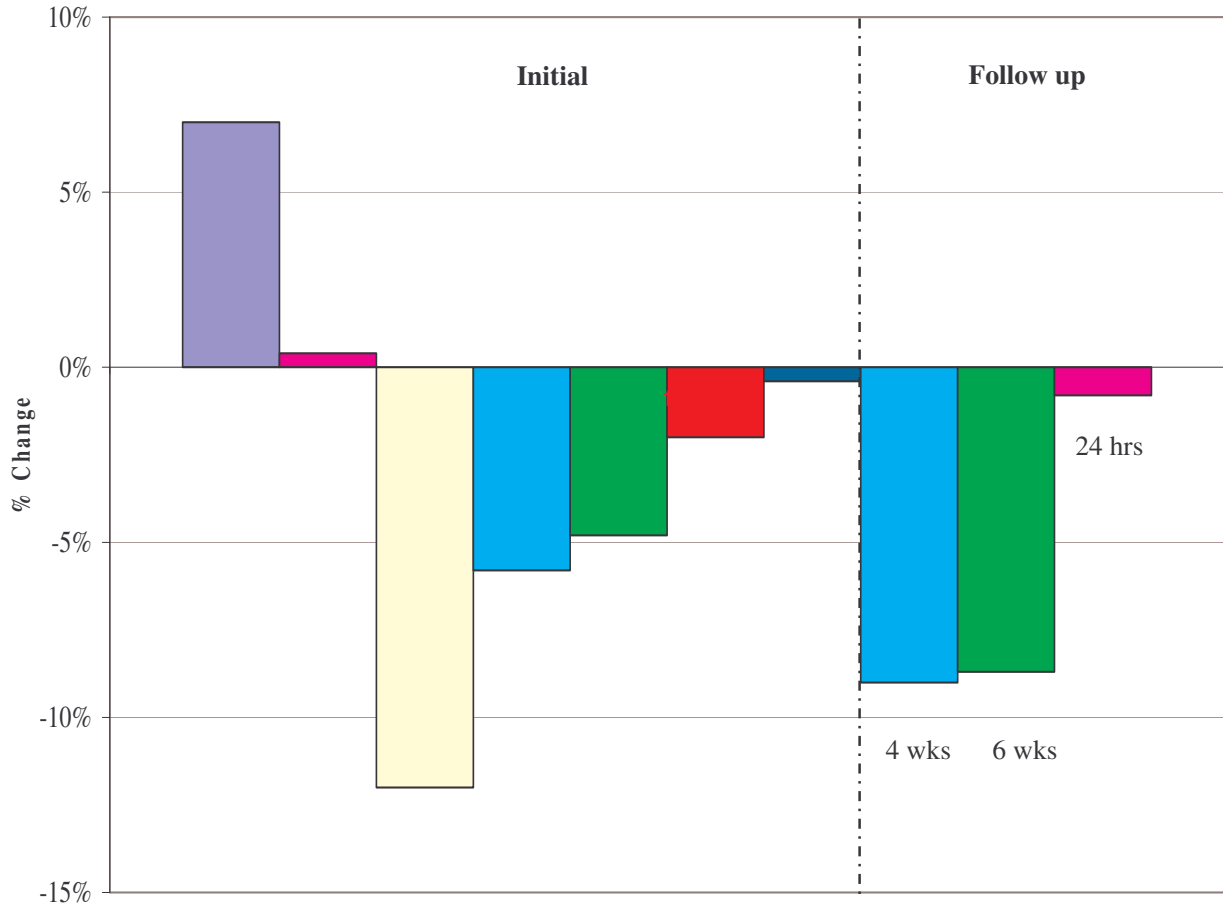
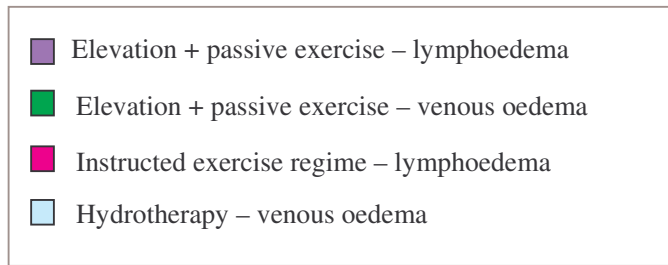
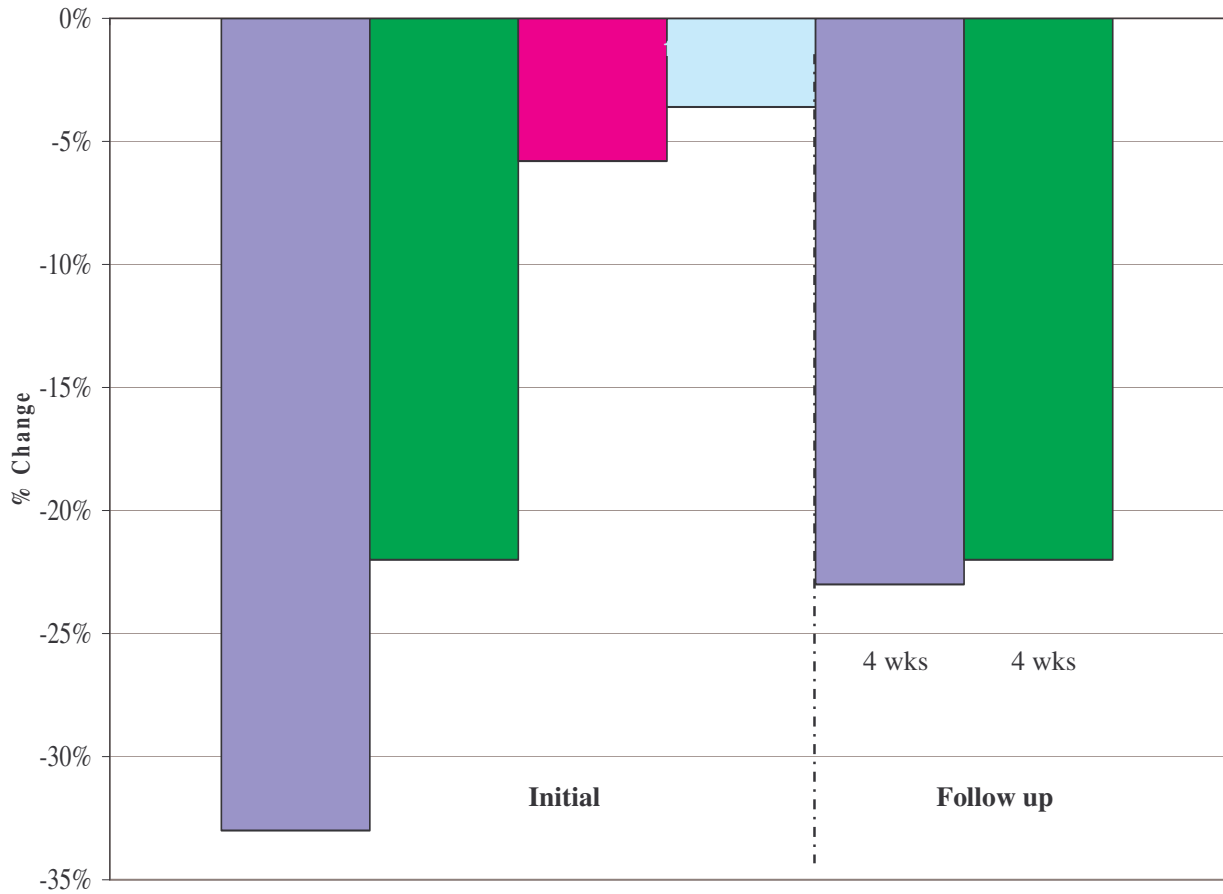

Figure 5b. Percentage leg volume change for different exercise regimes in leg lymphoedema & venous oedema; initial (post trial) reduction and follow up reduction



Chapter 5. Discussion of the Importance of Exercise Regimes for Limb Oedemas

Limb swelling, whether it be of lymphatic or vascular origin is essentially an imbalance between tissue infiltrate and drainage. This imbalance contributes to the deleterious effects on the capillary and lymphatic network, skin and epifascial tissue composition. The swelling and its associated changes also gives rise to a number of subjective limb symptoms which often negatively impact upon the individual's quality of life. As the imbalance is generally not rectifiable, the oedematous limb will worsen in severity over time. This makes the accurate measurement and quantification of the limb and the implementation of an appropriate treatment regime vital.

It is hoped that with newer techniques, such as sentinel node biopsy for staging melanoma and breast cancer, the tailoring of irradiation fields and less invasive surgical techniques for the correction of vascular insufficiency that the incidence of both peripheral lymphoedema and venous oedema will lessen. However, the questions of how to improve fluid flow, reverse the adverse effects of dysfunctional drainage and how to effectively manage the oedematous limb still remain.

This is why, over the years, various modalities have evolved to treat and manage the oedematous limb. Less commonly used therapies such as ultrasound, vibration, magnetic and thermal therapy have shown varying results and generally work best in combination with other treatments such as compression and oral benzopyrones. The use of autologous lymphocytes to stimulate macrophage phagocytosis holds promise, but requires further research to determine the full benefits. Various surgical techniques are also used, but are

generally reserved for patients with severe limb swelling and deformity for whom conservative therapies have yielded poor outcomes. This means that in the majority of cases, conservative therapies are administered by health professionals or undertaken by the patient to either reduce the limb and its associated problems or to stop the condition from getting progressively worse.

The therapies administered by health professionals require specific training, knowledge, expertise and resources and are generally more intensive in nature. Such therapies include complex physical therapy, manual lymphatic drainage, compression bandaging, pneumatic pump therapy, laser therapy and the prescription of particular oral pharmaceuticals. Despite the poor rigour of some of the research designed to test these professionally administered therapies, the systematic review undertaken (chapter 3) demonstrated a varying degree of beneficial outcomes.

These included limb volume and percentage reductions and improvements in both subjective symptoms and quality of life. The effects of manual lymphatic drainage, compression bandaging and garments have also been reviewed by Badger et al (2004). Although the authors found that MLD did not confer additional benefits in terms of limb reduction and that compression is beneficial for limb maintenance, they felt that “definitive” recommendations could not be made about the effectiveness of these different treatment modalities.

An earlier review by Badger et al (2003) of oral Benzopyrones (5,6 Benzo-a-pyrone, Coumarin, Cyclo-3-Fort, Daflon, Oxerutin) found reductions in limb volume (when compared to placebo) and in particular subjective limb symptoms, which is similar to the outcomes observed in the undertaken systematic review. Again the authors felt that it was not possible

to draw definitive conclusions about the effectiveness of Benzopyrones for lymphoedema treatment from the trials reviewed. A review of chronic venous insufficiency and the effect of phlebotonics such as Rutosides, Hidrosimine plus Diosine, Calcium Dobesilate, Atella Asiatica, Pine Bark and Grape Seed Extract (Martinez, Bonfill, Moreno et al 2005) found benefits in terms of oedema reduction, improvements in trophic skin changes and restless legs but that these results should be “interpreted with caution”.

The systematic review of the conservative therapies (chapter 3) demonstrated that to maintain the initial reductions achieved in the initial trial, additional therapy needed to be undertaken. Also, in many cases, the best results were obtained by not one treatment strategy working in isolation but through a combination (and/or appropriate sequencing) of therapies. These aforementioned factors require additional input, both in terms of clinical time and economic resources (especially on behalf of the patient). However, the resources, time and qualified professionals are not always available or accessible to the patient and therefore alternative regimes are often sought and implemented instead.

The review of the self maintenance therapies revealed that small to modest reductions in limb volume are to be expected. This was particularly the case for self massage (30mls ~ 3.0%), some class II compression garments (30 – 80mls, ~ 3.0 - 8.0%) and the arm exercise regimes (12 - 52mls, 1.2 – 5.2%). The maintenance regimes did, however, consistently reduce reported subjective limb symptoms and at times improved other domains such as psychological distress and work/leisure activities. This indicates that self administered therapies are indeed beneficial for patients to undertake (when appropriately reviewed and supervised by a health care professional).

Although limb exercise is often incorporated into overall treatment regimes for limb oedemas, the stand alone benefits of such exercise has only recently started to emerge. This includes physical programs and hydrotherapy for arm lymphoedema (Box et al 2004; Johansson et al 2004; McKenzie & Kalda 2003) and chronic venous insufficiency (Padberg et al 2004; Yang et al 1999; Ciocon et al 1995; Ernst et al 1991). It is, however, surprising that there is not more research in this area, considering the established benefits that exercise has on lymphatic and venous flow through changes in interstitial pressures and activation of the calf muscle pump. Based upon these benefits that exercise can have for those with oedematous conditions, four clinical trials with exercise as the core component were undertaken.

The first two trials investigated the benefits of equipment which delivered both elevation and passive exercise to those with lower limb swelling related to previous cancer treatment (lymphoedema) or chronic venous insufficiency (oedema). This machine and was used in the home environment over a 3 week period. After three weeks both the lymphoedema and oedema group had a significant reductions in limb volume and weight. These reductions occurred steadily over each week of treatment, first reaching significance after 2 weeks of treatment. These were also accompanying improvements in percentage body fat and body mass index.

This regime also significantly improved perceived limb size and discomfort, most notably pain, heaviness and tightness. The improvement in subjective symptoms also positively correlated with improved quality of life and psychosocial issues in both conditions. At one month follow up a proportion (100mls ~ 10%) of the limb volume had returned in the lymphoedema group, whilst both groups maintained the reduction in body weight. There were some increases in subjective leg symptoms, but these had not returned to pre-treatment levels. The maintenance

of these parameters may indicate an ongoing effect of this regime or an increased level of well being and activity, which had a positive impact upon limb swelling and perceived discomfort.

The limb volume reductions (330mls and 220mls; 33.0% and 22.0%) achieved by this regime are superior to the volume reduction of 36mls (~ 4.0%) attained from hydrotherapy for chronic venous insufficiency (Ernst et al 1991). They were also greater than the volume reductions attained in some class II compression garment studies, which ranged from 25 - 43mls, ~ 2.5 – 4.4% (Diehm et al 1996; Ukuaf et al 1996) and oral pharmaceutical studies which ranged from 10 - 90mls, ~ 1.0 – 9.0% (Knocker et al 1999; Rehn et al 1996). They were comparable to those achieved in the study involving class II compression (230mls, 22.8%) by Nueman & Van der Broek (1995) and class II compression plus oral SB-LOT (120mls, 12.0%) by Vanscheidt et al (2002). The improvements in subjective symptoms were similar to those seen to occur in all therapies for leg swelling. Most importantly, these two trials demonstrated significant improvements in quality of life domains (such as ability to undertake physical activity and emotional well being), which are often a considerable problem for these patient populations and an area not extensively explored in previous clinical trials.

The third trial investigated the benefits of a 10 minute combined arm exercise and deep breathing program. This regime was based on the philosophy of changes in inter-thoracic pressure improving lymphatic return from the limb and the changes in interstitial pressure caused by muscle movement improving both lymph absorption and transport. Directly after performing this program there was a significant reduction in arm volume and a reduction in truncal fluid, with both reductions persisting 30 minutes post regime. There were also significant reductions in reported arm heaviness and tightness.

The greatest benefits from this particular regime were seen in women who continued to perform the 10 minute regime at home, morning and evening for 1 month. This resulted in greater reductions in arm volume and truncal fluid and improvements in reported heaviness and perceived limb size. There was also significant tissue softening in the lymphatic territory located in the anterior thorax area. All of these improvements were significant in comparison to a control group who were also measured over a 1 month period. Importantly, this study found that participants who responded to the initial program were more likely to continue to improve if they performed the program over the 1 month period.

The initial volume reduction obtained from the combined exercise and deep breathing program was modest (52mls, 5.8%), especially in contrast to more intensive programs such as CPT, which ranges from a 298 - 652mls (30.0 – 65.0%) reduction (Szuba et al 2002; Casley-Smith & Casley-Smith 1992) and MLD plus bandaging, which ranges from a 156 - 246mls (16.0 – 25.0%) reduction (McNeeley et al 2004; Korpon et al 2003). However, the volume reduction achieved initially, and at 1 month was greater in comparison to hydrotherapy (32-48mls, 4.8% - 12%, Box et al 2004; Johansson et al 2004) and resistive exercise (2%, Mckenzie & Kalda 2003). The one month volume reduction of 101mls (9%) was also greater than the 7.0 – 8.0% reductions achieved by some class II compression garments (Korpon et al 2003; Johansson et al 1998; Swedborg 1984).

The improvements in arm subjective symptoms in the arm exercise plus deep breathing trial are in concert with those achieved by hydrotherapy (Box et al 2004), laser therapy (Carati et al 2003; Piller & Thelander 1996), compression alone and in combination with MLD (Korpon et al 2003; Anderson et al 2000; Johansson et al 1999). As very few studies have explored the impact of therapy on tissue composition, it is hard to know how the improvement in the

anterior thorax tissue compares with other therapies. None the less, it is an important finding that indicates that this form of exercise not only reduces limb volume but can also improve tissue composition in certain lymphatic territories.

The final trial was a pilot study of the effect of sequential limb exercise in combination with initial deep breathing and self massage for those with either secondary arm or leg lymphoedema. Directly after this regime there was little effect on arm fluid volume, with a net decrease of 12mls (0.4%) 20 minutes post regime. Those with leg lymphoedema had a greater reduction of 110mls (10.4%) which persisted at the 20 minute mark. Interestingly, both groups had an initial reduction in truncal fluid of 100mls, which is most likely related to the deep breathing component of the regime. Both groups also had improvements in subjective symptoms, especially tightness and heaviness and in limb range of movement.

The net arm volume reduction of 12mls (0.4%) achieved in this pilot study was small in comparison to the 2 – 4.8% reduction achieved in other exercise studies (Box et al 2004; Mckenzie & Kalda 2003) and the 3.0% achieved by self massage (William et al 2002). The volume reduction of 55mls (5.8%, as measured by perometry) experienced in the leg lymphoedema group was not equal to that achieved by the Aerobic Exerciser (330mls, 33.0%), but was similar to the 6.3% (average) produced by pump therapy (Bergen et al 1998) and greater than the 2.9% achieved by leg elevation (Xia et al 2004).

The improvements in subjective symptoms in this pilot study once again mirrored those seen in other conservative therapies for both leg and arm lymphoedema. The improvement in limb function concurs with results from other exercise regimes including a dance program (Sandel et al 2005), the Aerobic Exerciser (Moseley et al 2004), hydrotherapy (Box et al 2004) and

resistive exercise (McKenzie & Kalda 2003). A similar improvement in limb function was also seen when taking oral Cyclo-3-Fort (Cluzan et al 1996).

The results from the four clinical trials demonstrate the various benefits of exercise regimes for oedematous limbs, with the limb volume reductions often being comparable to those achieved by health professional administered therapies such as pump therapy and oral pharmaceuticals. They were also comparable to the reductions obtained from existing exercise programs (as seen by figures 4.5a and 4.5b) and self maintenance regimes such as self massage and class II compression garments. The four trials also revealed the important benefits exercise can have on both limb function and quality of life. Due to the chronicity of limb oedema, the negative effects upon these aforementioned issues have often been emphasised in the literature (Pereira de Godoy et al 2002; Brenda 2001; Caseley-Smith 2001; Nicolaidis 2000) and highlights the important role exercise has in potentially reducing the morbidity of these conditions.

All therapies, whether administered by the health professional or the patient are going to have variable effects depending upon individual suitability and compliance. None the less, the systematic review of conservative therapies for limb oedemas has shown that implementing some form of therapy is generally better than doing nothing at all. However, not only do the treatment benefits of these therapies need to be considered, but also the likelihood of compliance to the regime, the economic cost and accessibility. This makes exercise regimes a viable option for most patients, as they are cost effective and can be implemented in the home environment, giving the patient a degree of self determination and control over their condition (in between health professional visits).

The results of the four studies were achieved in those with well established limb swelling and certainly contribute to the existing knowledge of the positive effects of exercise. The exercise regimes also addressed other central issues of these potentially debilitating conditions, such as limb mobility, weight maintenance, quality of life and general well being. Overall, these results give both health care professionals and patients the confidence to implement these exercise regimes with the anticipation of some benefit, either as an alternative or adjunct to other conservative therapies.

Recommendations

From the systematic review and the outcomes of the four clinical trials undertaken, a number of recommendations can be made regarding exercise regimes for limb oedemas, these are;

- 1) Exercise can be undertaken by patients with either lymphatic or venous limb oedema with out precipitating or exacerbating the condition.
- 2) Exercise can be implemented in the home environment by the patient with the expectation of beneficial outcomes. However, it is important that the patient is regularly reviewed by a health professional to objectively assess the limb and it's response to treatment/maintenance.
- 3) Exercise can be targeted to individual needs, with the 10 minute exercise plus deep breathing program being shown to be of more long term benefit to those who initially demonstrated a positive response.
- 4) Exercise can compliment existing conservative therapies and can be implemented as an alternative when conservative therapies are not available or accessible.
- 5) Health professionals and patients can confidently instigate exercise regimes with anticipated benefits in limb volume, subjective symptoms, limb functioning and quality of life.

References

Aboul-Enein, A., Eshmawy, I., Adrafa, S., & Abboud A., 1984, 'The role of lymphovenous communication in the development of postmastectomy lymphedema', *Surg*, vol. 95, no. 5, 562-6.

Adair, T. H. & Guyton, A. C., 1983, 'Modification of lymph by lymph nodes. II. Effect of increased lymph node venous blood pressure', *Am J Physiol*, vol. 245, H616-622.

Adair, T. H. & Guyton, A. C., 1985, 'Modification of lymph by lymph nodes. III. Effect of increased lymph hydrostatic pressure', *Am J Physiol*, vol. 249, H777-782.

Andersen, L., Hojris, I., Erlandsen, M. & Andersen, J., 2000, 'Treatment of breast-cancer-related lymphedema with or without manual lymphatic drainage. A randomized study', *Acta Oncologica*, vol. 39, no. 3, 399-405.

Ang, N., Saraswathi, N. & Chan H., 2003, 'Outcome study on the effectiveness of two different modified lymphoedema management protocols for post-mastectomy patients: A pilot study', *IVth Australasian Lymphology Association Conference Proceedings*, 7-17.

Antoch, G., Pourhassan, S., Hansen, O. & Stock W., Feb 2002, 'Comparison of colour Doppler ultrasonography, ascending phlebography and clinical examination in the diagnosis of incompetent calf perforating veins', *Brit J Surg*, vol. 89, no. 2, 192-3.

Arnold, L., Witzman, K., Swank, M., McElroy, S.L. & Keck, P.E. Jr., 2000, 'Health-related quality of life using the SF-36 in patients with bipolar disorder compared with patients with chronic back pain and the general population', *J Affect Disord*, vol. 57, 235-9.

Asmussen, P.D., 2003, 'Compression Therapy' in *Textbook of Lymphology for Physicians and Lymphedema Therapists*, Földi, M., Földi, E. & Kubik, S., (eds), Elsevier GmbH, Germany, 540.

Azevedo, W., Couto, E., Gomes, C., et al., 2001, 'A reliable and valid quality of life test in patients with lymphoedema – version of the SF – 36', *Europ J Lymph*, vol. 9, 73.

Azzali, G., 1999, 'The lymphatic vessels and the so-called "lymphatic stomata" of the diaphragm: a morphologic ultrastructural and three-dimensional study', *Microvas Res*, vol. 57, no. 1, 30-43.

Badger, C., Seers, K., Preston, N. & Mortimer, P., 2004, 'Physical therapies for reducing and controlling lymphoedema of the limbs (Cochrane Review), *Cochrane Database of Systematic Reviews*, Issue 4, CD003141

Badger, C., Preston, N., Seers K. & Mortimer P., 2003, 'Benzopyrones for reducing and controlling lymphoedema of the limbs', *Cochrane Database of Systematic Reviews*, Issue 2, CD003140.

Balzarini, A., Pirovano, C., Diazzi, G., Olivieri, R., Ferla, F., Galperti, G., Sensi, S. & Martino, G., Sep 1993, 'Ultrasound therapy of chronic arm lymphedema after surgical treatment of breast cancer', *Lymphology*, vol. 26, no. 3, 128-34.

Balzerr, K. & Schonebeck, I., Dec 1993, 'Gefasschirurgischen Klinik, Evangelischen Krankenhauses, Mulheim an der Ruhr [Edema after vascular surgery interventions and its therapy]', *Zeitschrift fur Lymphologie – J Lymphology*, vol. 17, no. 2, 41-7.

Bates, D.O., Levick, J.R. & Mortimer, P.S., 1993, 'Change in macromolecular composition of interstitial fluid from swollen arms after breast cancer treatment and its implications', *Clinical Science* vol. 86, 737-46.

Baumeister, R.G. & Siuda, S., Jan 1990, 'Treatment of lymphedemas by microsurgical lymphatic grafting: what is proved?', *Plastic Reconstruct Surg*, vol. 85, no. 1, 64-74.

Benson, H. & Friedman, R., 1996, 'Harnessing the power of the placebo effect and renaming it "remembered wellness"', *Ann Rev Med*, vol. 47, 193-99.

Berens von Rautenfeld, D. & Schacht, V., 2003, 'Fundamentals of comparative lymphology' in *Textbook of Lymphology for Physicians and Lymphedema Therapists*, Földi, M., Földi, E. & Kubik, S., (eds), Elsevier GmbH, Germany, 185

Bergan, J.J., Sparks, S. & Angle, N., 1998, 'A comparison of compression pumps in the treatment of lymphedema', *Vasc Surg*, vol. 32, 455-462.

Bernas, M.J., Witte, C.L. & Witte, M.H., 2001, 'The diagnosis and treatment of peripheral lymphedema. Draft revision of the 1995 Consensus Document of the International Society of Lymphology Executive Committee for Discussion at the September 3 – 76, 2001, XVIII International Congress of Lymphology in Genoa, Italy'. *Lymphology*, vol. 34, 84-91.

Bilek, K., Ebeling, K., Leitsmann, H. & Seidel, G., 1981, 'Problems of radiotherapy in radically removed cervix cancers in stages T1b NO MO. Preliminary results of a randomized clinical trial', *Zentralblatt fur Gynakologie*, vol. 103, no. 17, 1014-22.

Bollinger, A., Pfister, G., Hoffman, U. & Franzeck, U.K., Oct-Dec 1989, 'Florescence microlymphography in chronic incompetence', *Int Angiology*, vol. 8, no. 4 (suppl), 23-6.

Boris, M., Weidorf, S. & Lasinski, P., Mar 1998, 'The risk of genital edema after external pump compression for lower limb lymphoedema', *Lymphology*, vol. 31, no. 1, 15-20.

Boris, M., Weindorf, S. & Lasinski, B., 1994, 'Lymphedema reduction by noninvasive complex lymphedema therapy', *Oncology*, vol. 8, no. 9, 95-106.

Box, R., Marnes, T. & Robertson, V., 2004, 'Aquatic physiotherapy and breast cancer related lymphoedema', *5th Australasain Lymphology Association Conference Proceedings*, 47-9.

Brautigam, P., Foldi, E., Schaiper, I., Krause, T., Vanscheidt, W. & Moser, E., Jun 1998, 'Analysis of lymphatic drainage in various forms of leg edema using two compartment lymphoscintigraphy', *Lymphology*, vol. 31, no. 2, 43-55.

Brenan, M.J. & Miller, L.T., 1998, 'Overview of treatment options and review of the current role and use of compression, intermittent pumps and exercise in the management of lymphedema', *Cancer*, vol. 83, suppl. 12B, 2821-27.

Brenda, K., 2001, 'Lymphoedema and quality of life – how to improve it?', *Europ J Lymph*, vol. 9, 72.

Brennan, M.J., DePompolo, R.W. & Garden, F.H., 1996, 'Focused review: Postmastectomy lymphedema', *Arch Phys Med Rehabil*, vol. 77, S74 – S80.

Brennan, M.J. & Miller, L.T., Dec 1998, 'Overview of treatment options and review of the current role and use of compression garments, intermittent pumps, and exercise in the management of lymphedema', *Cancer (suppl)*, vol. 83, no. 12, 2821-827.

Brorson, H., Svensson, H., Norrgren, K. & Thorsson, O., 1998, 'Liposuction reduces arm lymphedema without significantly altering the already impaired lymph transport', *Lymphology*, vol. 31, 156-72.

- Brorson, H., 2003, 'Liposuction in arm lymphedema treatment', *Scandin J Surg*, vol. 92, no. 4, 287-95.
- Browning, C. 1997, 'Lymphoedema: prevalence, risk factors and management: a review of research', *NHMRC National Breast Cancer Centre*, Sydney.
- Browse, N.L. & Burnand, K.G., 1982, 'The cause of venous ulceration', *Lancet*, vol. 2, 243-245.
- Bry, J.D.L., Muto, P.A. & O'Donnell, T.F., 1995, 'The clinical and hemodynamic results after axillary-to-popliteal vein valve transplantation', *J Vasc Surg*, vol. 21, 110-19.
- Buckley, G., Piller, N. & Moseley, A., Mar 2004, 'Can exercise improve lymphatic flow? A pilot trial of the objective measurement of fluid movement in subjects with mild secondary lymphoedema', *5th Australasian Lymphology Association Conference Proceedings*, 37 – 42.
- Bull, R.H., Gane, J.N., Evans, J.E., Joseph, A.E. & Mortimer, P.S., Apr 1993, 'Abnormal lymph drainage in patients with chronic venous ulcers', *J Amer Academic Derm*, vol. 28, no. 4, 585-90.
- Bunce, I.H., Mirolo, B.R., Hennessy, J.M., Ward, L.C. & Jones, L.C., 1994, 'Post-mastectomy lymphoedema treatment and measurement', *Med J Aus*, vol. 161, 125-127.
- Burgos, A., Alcaide, A., Alcoba, C., Azcona, J.M., Garrido, J., Lorente, C.M., Orena, E., Murillo, E., Olsina-Pavia, J., Olsina-Kissler, J., Samaniego, E. & Serra, M., 1999, 'Comparative study of the clinical efficacy of two different coumarin dosages in the management of arm lymphedema after treatment for breast cancer', *Lymphology*, vol. 32, 3-10.
- Burnand, K.G., McGuinness, C.L., Lagattolla, N.R., Browse, N.L., El-Aradi, A. & Nunan, T., Jan 2002, 'Value of isotope lymphography in the diagnosis of lymphoedema of the leg', *Brit J Surg*, vol. 89, no. 1, 74-8.
- Cambria, R.A., Glovicki, P., Naessens, J.M. & Wahner, H.W., Nov 1993, 'Noninvasive evaluation of the lymphatic system with lymphoscintigraphy: a prospective, semiquantitative analysis in 386 extremities', *J Vas Surg*, vol. 18, no. 5, 773-82.
- Campisi, C., Michelini, S. & Boccardo, F., 2004, 'Guidelines of the Società Italiana Lifangiologia', <http://www.u.arizona.edu/~witte/ISL.htm>

Campisi, C., Boccardo, F., Zilli, A., Maccio, A. & Napoli, F., 2001 'The use of vein grafts in the treatment of peripheral lymphedemas: long-term results'; *Microsurgery*, vol. 21 no .2, 143-7.

Campisi, C., Boccardo, F., Zilli, A., Maccio, A. & Napoli, F., 2001, 'Long-term results after lymphatic-venous anastomoses for the treatment of obstructive lymphedema', *Microsurgery*, vol 21, no. 4, 135-9.

Campisi, C. & Boccardo, F., Mar 1999, 'Role of microsurgery in the management of lymphedema', *Int Angiology*, vol. 8, no. 1, 47-51.

Carati, C.J., Anderson, S.N., Gannon, B.J. & Piller, N.B., Sep 2003, 'Treatment of postmastectomy lymphedema with low-level laser therapy', *Cancer*, vol. 98, no. 6, 1114-1122.

Carroll, D. & Rose, K., 1992, 'Treatment leads to significant improvement. Effect of conservative treatment on pain in lymphoedema', *Prof Nurse*, vol. 8, no. 1, 32-36.

Case, T.C., Witte, C.L., Witte, M.H., Unger, E.C. & Williams, W.H., 1992, 'Magnetic resonance imaging in human lymphedema: comparison with lymphoscintigraphy', *Magnetic Resonance Imaging*, vol. 10, no. 4, 549-58.

Casley-Smith, J.R., Clodius, L. & Piller, N.B., Sep 1980, 'Tissue changes in chronic experimental lymphoedema in dogs', *Lymphology*, vol. 13, no. 3, 130-41.

Casley-Smith, J.R., 1983, 'Varying total tissue pressure and the concentration of initial lymphatic lymph', *Microvasc Res*, vol. 25, 69-379.

Casley-Smith, J.R., 1988, 'A double-blind trial of calcium dobesilate in chronic venous insufficiency', *Angiology*, vol. 39, no. 10, 853-857.

Casley-Smith, J.R. & Casley-Smith, J.R., 1992 'Modern treatment of lymphoedema I. Complex physical therapy: the first 200 Australian limbs', *Australas J Dermatol*, vol. 33, 61-8.

Casley-Smith, J.R. & Casley-Smith J.R., 1992, 'Modern treatment of lymphoedema. II. The benzopyrones', *Australasian J Derma*, vol. 33, no. 2, 69-74.

Casley-Smith, J.R., Morgan, R.G. & Piller, N.B., 1993, 'Treatment of lymphedema of the arms and legs with 5,6-BENZO-[á]-PYRONE', *New Eng J Med*, vol. 329, no. 16, 1158-1163.

Casley-Smith, J.R. & Casley-Smith, J.R., 1994, 'Volume alterations in lymphoedema; untreated, and after complex therapy (C.P.T), benzo-pyrones, or both', *Lymphology*, vol. 27, suppl, 627-631.

Casley-Smith, J.R. & Casley-Smith, J.R., 1994, 'Modern treatment for lymphoedema', University of Adelaide, Australia, 67, 69

Casley-Smith, J.R. & Casley-Smith, J.R. 1997, 'Modern Treatment for Lymphoedema (5th Ed)', Terrace Printing, Australia, 138-139, 151.

Casley-Smith, J.R., Boris, M., Weindorf, S. & Lasinski, B., Dec 1998, 'Treatment for lymphoedema of the arm – The Casley-Smith Method', *Cancer (suppl)*, vol. 83, no. 12, 2843-860

Casley-Smith, J., 2001, 'Psycho-social and physical issues affecting patients with lymphoedema', *Europ J Lymph*, vol. 9, 73.

Castejon, R., Gamallo, C. & Jimenez-Cossio, J., Dec 1990, 'An experimental study of lymphatic vessel autotrasplantation in the dog', *Lymphology*, vol. 23, no. 4, 194-7.

Cha, K., Chertow, G.M., Gonzalez, J., Lazarus, J.M. & Wilmore, D.W., Oct 1995, Multi-frequency bioelectrical impedance estimates the distribution of body water', *J Appl Phys*, vol. 79, no. 4, 1316-9.

Chan, Y.K., Chiu, K.Y., Cheng, S.W. & Ho, P., Dec 2004, 'The incidence of deep vein thrombosis in elderly Chinese suffering hip fracture is low without prophylaxis: a prospective study using serial duplex ultrasound', *J Ortho Surg*, vol. 12, no. 2, 178-83.

Chang, T.S., Han, L.Y., Gan, J.L. & Huang, W.Y., Mar 1989, 'Microwave: an alternative to electric heating in the treatment of peripheral lymphedema', *Lymphology*, vol. 22, no. 1, 20-4.

Chang, T.S., Gan, J.L., Fu, K.D. & Huang, W.Y., Sep 1996, 'The use of 5,6 benzo-[alpha]-pyrone (coumarin) and heating by microwaves in the treatment of chronic lymphedema of the legs', *Lymphology*, vol. 29, no. 3, 106-11.

Cheatle, T.R., Scurr, T.H. & Coleridge-Smith, P.D., Jun 1991, 'Drug treatment of chronic venous insufficiency and venous ulceration: A review', *Roy Soc Med*, vol. 84, no. 6, 354-58.

Chen, H.C., O'Brien, B.M., Pribaz, J.J. & Roberts, A.H., Jul 1988, 'The use of tonometry in the assessment of upper extremity lymphoedema', *Brit J Plast Surg*, vol. 41, no. 4, 399-402.

Chen, H.C., O'Brien, B.M., Rogers, I.W., Pribaz, J.J. & Eaton, C.J., Sep 1990, 'Lymph node transfer for the treatment of obstructive lymphoedema in the canine model', *Brit J Plastic Surg*, vol. 433, no. 5, 578-86.

Christopoulos, D.G., Nicolaides, A.N., Szendro, G., Irvine, A.T. & Eastcott, H.H., 1987, 'Air-plethysmography and the effect of elastic compression on hemodynamics of the leg', *J Vasc Surg*, vol 5, 148-59.

Ciocon, J.O., Galindo-Ciocon, D. & Galindo, D.J., Jan 1995, 'Raised leg exercises for leg edema in the elderly', *Angiology*, vol. 46, no. 1, 19-25.

Ciostek, P., Michalak, J. & Noszczyk, W., Nov 2004, 'Improvement in deep vein haemodynamics following surgery for varicose veins', *Eur J Vasc & Endovasc Surg*, vol. 28 no. 5, 473-8.

Clement, D.L., Jan 2000, 'Management of venous edema: Insights from an international task force', *Angiology*, vol. 51, no. 1, 13-17.

Clodius, L., 1982, 'Problems of microsurgery in lymphedema', *Handchirurgie, Mikrochirurgie, Plastische Chirurgie*, vol. 14, no. 2, 79-82.

Clodius, L., Deak, N. & Piller, N., 1976, 'A new instrument for the evaluation of tissue tonometry in lymphoedema', *Lymphology*, vol. 9, 1-5.

Cluzan, R.V., Alliot, F., Ghabboun, S. & Pascot, M., 1996, 'Treatment of secondary lymphedema of the upper limb with Cyclo 3 Fort', *Lymphology*, vol. 29, 29-35.

Coates, G., O'Brodovich, H. & Goeree, G., 1993, 'Hindlimb and lung lymph flows during prolonged exercise', *J Appl Physiol*, vol. 75, no. 2, 633-8.

Cohen, S.R., Payne, D.K. & Tunckel, R.S., Aug 2001, 'Lymphedema: strategies for management', *Cancer*, vol. 92 no. 4 (suppl), 980-7.

Cohen, S.R., Mount, B.M., Bruera, E., Provost, M., Rowe J. & Tong, K., 1997, 'Validity of the McGill Quality of Life Questionnaire in the palliative care setting: a multi-centre Canadian study demonstrating the importance of the existential domain', *Pall Med*, vol. 11, 3-20.

Cornish, B.H., Bunce, I.H., Ward, L.C., Jones, L.C. & Thomas, B.J., 1996, 'Bioelectrical impedance for monitoring the efficacy of lymphoedema treatment programmes', *Breast Cancer Res & Treat*, vol. 38, no. 2, 169-76.

Cornish, B., Chapman, M., Hirst, C., Mirolo, B., Bunce, I.H., Ward, L.C. & Thomas, B.J. 2001, 'Early diagnosis of lymphedema using multifrequency bioimpedance', *Lymphology* vol. 34, no. 1, 2-11.

Coster, S., Poole, K. & Fallowfield, L.J., Aug 2001, 'The validation of a quality of life scale to assess the impact of arm morbidity in breast cancer patients post-operatively', *Breast Cancer Res & Treat*, vol. 68, no. 3, 273-82.

Dar'oczy, J., 1992, 'Morphologische Veränderungen des Bindegewebes beim chronischen lymphödem' in: *Lymphologica*. Berens, V., Rautenfeld. & Weisslede, H.(eds), Kagew Kommunikation, Bonn: 66-67.

Deo, S.V., Ray, S., Rath, G.K., Shukla, N.K., Kar, M., Asthana, S. & Raina, V. Jan-Mar 2004, 'Prevalence and risk factors for development of lymphedema following breast cancer treatment', *Ind J Cancer*, vol. 41, no. 12.

Dereppe, H., Hoylaerts, M., Renard, M., Leduc, O., Bernard, R. & Leduc, A., 1990, 'Répercussions hémodynamiques de la pressothérapie', *J Maladies Vasculaires, Masson*, vol. 15, 267-269.

Diehm, C., Trampisch, H.J., Lange, S. & Schmidt, C., Feb 1996, 'Comparison of leg compression stocking and oral horse-chestnut seed extract therapy in patient with chronic venous insufficiency', *Lancet*, vol. 347, no. 8997, 292-294.

Dubois, F., 2004, 'Comparison between applying manual lymphatic drainage only, applying sequential pressotherapy by Lympha-Press itself, and the combination of using both applications', <http://www.lympha-press.com/pdf/phystreatment.pdf>.

Eliska, O. & Eliskova, M., Mar 1995, 'Are peripheral lymphatics damaged by high pressure manual massage?', *Lymphology*, vol. 29, no. 1, 21-30.

Ernst, E., Saradeth, T. & Resch, K.L. 1991, 'A single blind randomized, controlled trial of hydrotherapy for varicose veins', *VASA*, vol. 20, no. 4, 147-151

Failde, I. & Ramos, I., 2000, 'Validity and reliability of the SF-36 Health Survey Questionnaire in patients with coronary artery disease', *J Clin Epidemiol*, vol. 53, 359-65.

Feied, C. & Weiss, R., Oct 2004, 'Chronic Venous Insufficiency', *Emedicine* (<http://www.emedicine.com/derm/topic474.htm>)

Földi, M., Földi, E. & Weissleder, H., 1985, 'Conservative treatment of lymphoedema of the limbs', *Angiology*, vol. 36, no. 3, 171-80.

Földi, E., Dec 1998, 'The treatment of Lymphedema', *Cancer (suppl)*, vol. 83, no. 12, 2833-827.

Földi, M., Földi, E. & Kubrik, S. (eds), 2003, 'Textbook of Lymphology for Physicians and Lymphedema Therapists', Elsevier, Germany, 496-7.

Földi, M., & Földi, E., 2003, 'Lymphostasis', in in *Textbook of Lymphology for Physicians and Lymphedema Therapists*, Földi, M., Földi, E. & Kubik, S., (eds), Elsevier GmbH, Germany, 240-41, 246.

Fowkes, F.G., Evans, C.J. & Lee, A.J., Aug 2001, 'Prevalence and risk factors of chronic venous insufficiency', *Angiology*, vol. 52, suppl. 1, S5-15.

Frullini, A., Weiss, R. & Schadeck, M., 2001, 'Varicose Veins and Chronic Venous Insufficiency in General Practice', *Information booklet*, 1-25.

Gaffney, R.M. & Casley-Smith, J.R., 1981, 'Excess plasma proteins as a cause of chronic inflammation and lymphedema: biochemical estimations', *J Pathol*, vol. 133, 229-42.

Gallagher, H., Garewal, D., Drake, R.E. & Gabel, J.C., Jun 1993, 'Estimation of lymph flow by relating lymphatic pump function to passive flow curves', *Lymphology*, vol. 26, no. 2, 56-60.

Gerli, R., Ibba, L., & Fruschelli, C., 1990 'A fibrillar elastic apparatus around human lymph capillaries', *Anat & Embry*, vol. 181, no. 3, 281-6.

Gloviczki, P., Bergan, J.J., Rhodes, J.M., Canton, L.G., Harmsen, S. & Ilstrup, D.M., 1999, 'Mid-term results of endoscopic perforator vein interruption for chronic insufficiency: Lessons learned from the North American subfascial endoscopic perforator surgery registry: The North American Study Group', *J Vasc Surg*, vol. 2, no. 9, 489-502

Gloviczki, P., Mar 1999, 'Principles of surgical treatment of chronic lymphoedema', *Int Angiology*, vol. 18, no. 1, 42-6.

Gray, H., 2002, 'Anatomy – Descriptive and Surgical', Paragon, United Kingdom, 434-36, 555- 560.

Gutting, B.W., Schomaker, S.J., Kaplan, A.H. & Amacher, D.E., Sep 1999, 'A comparison of the direct and reporter antigen popliteal lymph node assay for the detection of immunomodulation by low molecular weight compounds', *Toxicological Sciences*, vol. 51, no. 1, 71-9.

Harris, S.R. & Niesen-Vertommen, S.L., Jun 2000, 'Challenging the myth of exercise-induced lymphedema following breast cancer: a series of case reports', *J Surg Oncol*, vol. 74, no. 2, 95-8.

Harris, S.R., Hugi, M.R., Olivotto, I.A. & Levine, M., Jan 2001, 'Clinical practice guidelines for the care and treatment of breast cancer: lymphedema', *CMA*, vol. 164, no. 2, 191-99.

Havas, E., Parviainen, T., Vuorela, J., Toivanen, J., Nikula, T. & Vihko, V., 1997, 'Lymph flow dynamics in exercising human skeletal muscle as detected by scintigraphy', *J Physiol*, vol. 504 (Pt 1), 233-39.

Havas, E., Lehtonen, M., Vuorela, J., Parviainen, T. & Vihko, V., 2000, 'Albumin clearance from human skeletal muscle during prolonged steady-state running', *Exp Physiol*, vol 85, no. 6, 863-8.

Heinz, L., Fishman, L., Farrar, R., Bernstein, R.K. & Zybert, P.A., 1994, 'Edema control in the management of disabling chronic venous insufficiency', *Arch Phys Med Rehab*, vol. 7, 436-441.

Herbertz., U., Apr 1998, 'Erysipelas and lymphedema', *Fortschritte der Medizin*, vol. 116, no. 12, 36-40.

Hidden, G., 1990, 'Some recent, or claiming to be recent, data on the superficial lymphatic circulation of the limbs', *J des Maladies Vasculaires*, vol. 15, no. 2, 149-51.

Hinrichs, C.S., Gibbs, J.F., Driscoll, D., Kepner, J.L., Wilkinson, N.W., Edge, S.B., Fassl, K.A., Muir, R. & Kraybill, W.G., 2004, 'The effectiveness of complete decongestive therapy for the treatment of lymphedema following groin dissection for melanoma', *J Surg Oncol*, vol. 85, no. 4, 187-92.

Hoffmann, J.N., Fertmann, J.P., Baumeister, R.G., Putz R. & Frick, A., Feb 2004, 'Tumescent and dry liposuction of lower extremities: differences in lymph vessel injury', *Plastic & Reconstruct Surg*, vol. 113, no. 2, 718-24

Hornsby, R., 1995, 'The use of compression to treat lymphoedema', *Prof Nurse*, vol. 11, no. 2, 127-128.

Hoult, J.R. & Paya, M., Jun 1996, 'Pharmacological and biochemical actions of simple coumarins: natural products with therapeutic potential', *General Pharmacology*, vol. 27, no. 4, 713-22.

Hu, X., Adamson, R.H., Liu, B., Curry, F.E. & Weinbaum, S., 2000, 'Starling forces that oppose filtration after tissue oncotic pressure is increased', *Am J Physiol Heart Circ Physiol*, vol. 279, H1724-1736.

Hwang, J.H., Kwon, J.Y., Lee, K.W., Choi, J.Y., Kim, B.T, Lee, B.B. & Kim, D.I., Mar 1999, 'Changes in lymphatic function after complex physical therapy for lymphoedema', *Lymphology*, vol. 32, no. 1, 15-21.

Iimura, A., Nakamura, Y. & Itoh, M., Jan 2003, 'Anatomical study of distribution of valves of the cutaneous veins of adult's limbs', *Ann Anat*, vol. 185, no. 1, 91-5.

International Society of Lymphology, 2003, 'The diagnosis and treatment of peripheral lymphedema, Consensus document of the International Society of Lymphology', *Lymphology*, vol. 36, 84-91.

Iokomi, E., Zweifach, B.W. & Schmid-Schonbein, G.W., Mar 1997, 'Fluid pressures in the rabbit popliteal afferent lymphatics during passive tissue movement', *Lymphology*, vol. 30, no. 1, 13-23.

Jantet, G., Jan 2000, 'RELIEF study: first consolidated European data. Reflux assessment and quality of life improvement with micronized flavonoids', *Angiology*, vol. 51, no. 1, 31-37

Jessup, G. & Lane, R.J., Nov 1988, 'Repair of incompetent venous valves: a new technique', *J Vasc Surg*, vol. 8, no. 5, 569-75.

Johansen, J., Taagehoj, F., Christensen, T., Overgaard, J. & Overgaard, M., Dec 1994, 'Quantitative magnetic resonance for assessment of radiation fibrosis after post-mastectomy radiotherapy', *Brit J Radiology*, vol. 67, no. 804, 1238-42.

Johansson, K., Lie, E., Ekdahl, C. & Lindfeldt, J., 1998, 'A randomized study comparing manual lymph drainage with sequential pneumatic compression for treatment of postoperative arm lymphedema', *Lymphology*, vol. 31, 56-64.

Johansson, K., Albertsson, M., Ingvar, C. & Ekdahl, C., 1999, 'Effects of compression bandaging with or without manual lymph drainage treatment in patients with postoperative arm lymphedema', *Lymphology*, vol. 32, 103-110.

Johansson, K., Ohlsson, K., Ingvar, C., Albertsson, M. & Ekdahl, C., Jun 2002, 'Factors associated with the development of arm lymphedema following breast cancer treatment: a match pair case-control study', *Lymphology*, vol. 35, no. 2, 59-71.

Johansson, K., Tibe, K., Kanne, L. & Skantz, H., 2004, 'Controlled physical training for arm lymphedema patients', *Lymphology*, vol. 37, suppl, 37-39.

Johnson, G., 1989, 'The Early History of Chronic Venous Insufficiency' in *Current Critical Problems in Vascular Surgery*, Veith, F. (ed), Quality Medical Publishing Inc, USA, 113-114.

Kahle, B. & Leng, K., May 2004, 'Efficacy of sclerotherapy in varicose veins - prospective, blinded, placebo-controlled study', *Dermatologic Surg*, vol. 30, no. 5, 723-8.

Kahn, S.R., Azoulay, L., Hirsch, A., Haber, M., Strulovitch, C. & Shrier, I. Feb 2003, 'Acute effects of exercise in patients with previous deep venous thrombosis: impact of the postthrombotic syndrome', *Chest*, vol. 123, no. 2, 399-405

Kaptchuk, T.J., 2002, 'The placebo effect in alternative medicine: Can the performance of healing ritual have clinical significance?', *Ann Inter Med*, vol. 136, no. 11, 817- 825.

Karges, J.R., Mark, B.E., Stikeleather, S.J. & Worrell, T.W., Feb 2003, 'Concurrent validity of upper-extremity volume estimates: comparison of calculated volume derived from girth measurements and water displacement volume', *Physical Therapy*, vol. 83, no. 2, 134-45.

Kasseroller, R., 1998, 'Compendium of Dr. Vodder's manual lymphatic massage', Karl F. Haug Verlag, Hüthig GmbH, Heidelberg, 67.

Kasseroller, R.G., 1998, 'The Vodder School. The Vodder Method', *Cancer*, vol. 83 (suppl), 2840-2.

Kerr, K.A., Watson, W.C. & Dalsing, M.C., 2004, 'Chronic Venous Disease' in *Vascular Nursing (4th Ed)*, Fahey, V.A. (Ed), Elsevier, USA, 399-425.

Kim, D.I., Huh, S., Lee, S.J., Hwang, J., Kim, Y.I. and Lee, B., 1998, 'Excision of subcutaneous tissue and deep fascia for advanced lymphedema', *Lymphology*, vol. 31, 190-4.

Kluner, C., Fischer T., Filimonow, S., Hamm, B. & Kroncke, T., Feb 2005, 'Endovenous treatment of primary varicose veins: an effective and safe therapeutic alternative to stripping?', *Fortschritte auf dem Gebiete der Rontgenstrahlen und der Nuklearmedizin*, vol. 17, no. 2, 179-87.

Knight, K.R., Ritz, M., Lepore, D.A., Booth, R., Octigan, K. & O'Brien, B.M., May 1994, 'Autologous lymphocyte therapy for experimental canine lymphoedema: a pilot study', *Aus & NZ J Surg*, vol. 64, no.5, 332-7.

Knight, K.R., Khazanchi, R.K., Pederson, W.C., McCann, J.J., Coe, S.A. & O'Brien, B.M., Jul 1989, 'Coumarin and 7-hydroxycoumarin treatment of canine obstructive lymphoedema', *Clinic Sci (London)*, vol. 77, no. 1, 69-76.

Knight, K.R., Collopy, P.A., McCann, J.J., Vanderkolk, C.A., Coe, S.A., Barton, R.M., Chen, H.C. & O'Brien, B., Nov 1987, 'Protein metabolism and fibrosis in experimental canine obstructive lymphedema', *J Lab Clin Med*, vol. 10, no. 5, 558-566.

Kohler, M., Michel, C. & Zimmermann, A., 1995, 'Histological changes after fractionated whole or partial irradiation of the rabbit urinary bladder', *Acta Oncologica*, vol. 34, no. 2, 199-204

Korpon, M.I., Vacariu, G., Schneider, B. & Fialka Moser, V., Aug 2003, 'Effects of compression therapy in patients with lymphedema after breast cancer surgery', *Annual Congresses of the American College of Phlebology*, San Diego, California.

Kubik, S., 1999, 'Anatomie des Lymphgefäßsystems' in *Lehrbuch der Lymphologie (4th ed)*, Földi, M. & Kubik, S. (eds), G. Fischer, Stuttgart, 2-203.

Kubik, S., 2003, 'Anatomy of the lymphatic system', in *Textbook of Lymphology for Physicians and Lymphedema Therapists*, Földi, M., Földi, E. & Kubik, S., (eds), Elsevier GmbH, Germany, 7-8, 37.

- Kuhn, E., Molnar, Z. & Bohm, K., Jul 1979, 'Postirradiation changes on the lymphatics studied by lymphography', *Rofo: Fortschritte auf dem Gebiete der Rontgenstrahlen und der Nuklearmedizin*, vol. 131, no. 1, 92-6,
- Labropoulos, N., Volteas, N., Leon, M., Sowade, O., Rulo, A., Giannoukas, A. & Nicolaides, A., Jan 1997, 'The role of venous outflow obstruction in patients with chronic venous dysfunction', *Arch Surg*, vol. 132, no. 1, 46-51.
- Labs, K., Tschoepf, M., Gamba, G., Aschwanden, M. & Jaeger, K.A., 2000, 'The reliability of leg circumference assessment: a comparison of spring tape measurements and optoelectronic volumetry', *Vasc Med*, vol. 5, no. 2, 69-74.
- Lane, K., Worsley, D. & McKenzie, D., 2005, 'Lymphoscintigraphy to evaluate the effects of upper body dynamic exercise and handgrip exercise on radiopharmaceutical clearance from hands of healthy females. *Lymph Res & Biol*, vol 3, no.1, 16-24.
- Lane, R.J., Cuzzilla, M.L. & McMahon, C.G., May 2003, 'Intermediate to long-term results of repairing incompetent multiple deep venous valves using external valvular stenting', *ANZ J Surg*, vol. 73, no. 5, 267-74.
- Launois, R., Reboul-Marty, J. & Henry, B. , Dec 1996, 'Construction and validation of a quality of life questionnaire in chronic lower limb venous insufficiency (CIVIQ)', *Quality of Life Res*, vol. 5, no. 6, 539-54.
- Lasheen, A.E., Hefny, M.R., El Askry, S.M. & Al Bakly, E., 2004, *Surg Today*, vol. 34, no. 12, 1057-60
- Leduc, A., Lievens, P. & Dewald, J., Dec 1981, 'The influence of multidirectional vibrations on wound healing and on regeneration of blood and lymph vessels', *Lymphology*, vol. 14, no. 4, 179-85.
- Leduc, O., Peeters, A. & Borgeois P., 1990, 'Bandages: scintigraphic demonstration of its efficacy on colloidal protein reabsorption during muscle activity', in *Progress in Lymphology XII Excerpta Med*, Nish et al (eds), Elsevier, 421-423.
- Leduc, O., Klien, P., Rasquin, C. et al 1992, 'Reliability of a volume measuring device (Volumeter[®]) for human limbs', *Eur J Lymphol*, vol. 3, 53-6.

Leduc, O., Leduc, A., Bourgeois, P. & Belgrado, J., Dec 1998, 'The physical treatment of upper limb edema', *Cancer (Supp)*, vol. 83, no. 12, 2835-2839.

Legnani, G., Zappa, B., Casolo, F., Adamini, R. & Magnani, P.L., Dec 2000, 'A model of an electro-goniometer and its calibration for biomechanical applications', *Med Eng & Physics*, vol. 22, no. 10, 711-22.

Levick, J.R., 1991 'Capillary filtration and extravascular influences', *J Exp Physiol*, vol. 76, no. 6, 825-857.

Lievens, P., June 1985, 'The influence of laser irradiation on the motricity of lymphatical system and on the wound healing process', *International Congress on Laser in Medicine and Surgery*, 171-174.

Lievens, P., 1991, 'The effect of a combined HeNe and I.R. laser treatment on the regeneration of the lymphatic system during the process of wound healing', *Lasers in Medical Science*, vol. 6, no. 193, 193-99.

Lin, J.C., Iafrati, M.D., O'Donnell, T.F. Jr., Estes, J.M. & Mackey, W.C., May 2004, 'Correlation of duplex ultrasound scanning-derived valve closure time and clinical classification in patients with small saphenous vein reflux: Is lesser saphenous vein truly lesser?', *J Vasc Surg*, vol. 39, no. 5, 1053-8.

Lindenblatt, N., Belusa, L., Tiefenbach, B., Schareck, W. & Olbrisch, R.R., Nov-Dec 2004, 'Prilocaine plasma levels and methemoglobinemia in patients undergoing tumescent liposuction involving less than 2,000 ml', *Aesth Plast Surg*, vol. 28, no. 6, 435-40.

Liu, N. & Olszewski, W., 1992, 'Use of tonometry to assess lower extremity lymphoedema', *Lymphology*, vol. 25, 155-8.

Lo, R.S., Woo, J., Zhoc, K.C., Yeo, W., Johnson, P., Mak, Y. & Lee, J., 2001, 'Cross-cultural validation of the McGill Quality of Life questionnaire in Hong Kong Chinese', *Pall Med*, vol. 15, 387-397.

Loprinzi, C.L., Kugler, J.W., Sloan, J.A., Rooke, T.W., Quella, S.K., Novotny, P., Mowat, R.B., Michalak, J.C., Stella, P.J., Levitt, R., Tschetter, L.K. & Windschitl, H., Feb 1999, 'Lack of effect of Coumarin in women with lymphedema after treatment for breast cancer', *New Eng J Med*, vol. 340, no. 5, 346-350

Markovic, S., Baskot, B., Ajdinovic, B., Pervulov, S., Gligic, B. & Perovanovic, M., 2001, 'Diagnostic validity of radionuclide phlebography in the detection of clinically occult deep venous thrombosis in patients with thromboembolism', *Vojnosanitetski Pregled*, vol. 58, no. 6, 611-4.

Marsch, W.C., Mar 2005, 'The lymphatic system and the skin. Classification, clinical aspects und histology', *Hautarzt*, vol. 56, no. 3, 277-93.

Martin, K.P. & Földi, E., 1996, 'Are hemodynamic factors important in arm lymphedema after treatment of breast cancer?', *Lymphology*, vol. 29, 155-57.

Martinez, M.J., Bonfill, X., Moreno, R.M., Vargas, E. & Capellà, D. 2005, 'Phlebotonics for venous insufficiency', *The Cochrane Database of Systematic Reviews*, Issue 3, no. CD003229

Mayrovitz, H.N., 2003, 'Limb volume estimates based on limb elliptical vs. circular cross section models', *Lymphology*, vol. 36, 140-143.

Mayrovitz, H.N., Sims, N., Hill, C.J., Hernandez, T., Greenshner, A. & Diep, H., 2006, 'Hand volume estimates based on a geometric algorithm in comparison to water displacement', *Lymphology*, vol. 39, 95-103.

Mazzoni, M.C., Skalak, T.C. & Schmid Shönbein, B.W., 1990, 'Effects of skeletal muscle fiber deformation on lymphatic volumes', *AM J Physiol*, vol. 259 (part 2): H 1860-8.

McCulley, S.J., Feb 1999, 'A new multiangle goniometer', *Annals Plast Surg*, vol. 42, no. 2, 221-2.

McGeown, J.G., McHale, N.G. & Thornbury, K.D., 1987, 'The role of external compression and movement in lymph propulsion in the sheep hind limb', *J Physiol*, vol. 387 83-93.

McHale, N.G. & Roddie, I.C., 1983, 'The effect of intravenous adrenaline and noradrenaline infusion of peripheral lymph flow in the sheep', *J Physiol*, vol. 341, 517-526.

McNeely, M.L., Magee, D.L., Lees, A.L., Bagnell, K.M., Haykowsky, M. & Hanson, J., 2004, 'The addition of manual lymphatic drainage to compression therapy for breast cancer related lymphedema: A randomized controlled trial', *Breast Cancer Treat & Res*, vol. 86, no. 2, 96 – 105.

McKenzie, D.C. & Kalda, A.L., Feb 2003, 'Effect of upper extremity exercise on secondary lymphedema in breast cancer patients: A pilot study', *J Clin Oncol*, vol. 21, no. 3, 463-466.

Mellor, R.H., Bush, N.L., Stanton, A.W., Bamber, J.C., Levick, J.R. & Mortimer, P.S., Nov-Dec 2004, 'Dual-frequency ultrasound examination of skin and subcutis thickness in breast cancer-related lymphedema', *Breast J*, vol. 10, no. 6, 496-503.

Michel, C.C., 1997, 'Starling: the formulation of his hypothesis of microvascular fluid exchange and its significance after 100 years', *J Exp Physiol*, vol. 82, no. 1, 1-30

Mikes, D., Cha, B., Dym, C., Baumgaertner, J., Hartzog, A.G., Tacey, A.D. & Calabria, M.R., 1999, 'Bioelectrical impedance analysis revisited', *Lymphology*, vol. 32, no. 4, 157-65.

Miller, L.T., 1996, 'The enigma of exercise: Participation in an exercise program after breast surgery', National Lymphoedema Network Newsletter, USA.

Miller, T.A., Wyatt, L.E. & Rudkin, G.H., 1998, 'Staged skin and subcutaneous excision for lymphedema: a favorable report of long-term results', *Plast Reconstr Surg*, vol. 102, 1486-1498.

Mislin, H., 1978, 'Vasomotor lymph drainage as a peripheral vascular association', *Lympho-Kinetics*, suppl. 33.

Moholkar, K. & Fenelon, G., 2001, 'Diurnal variations in volume of the foot and ankle', *J Foot Ankle Surg*, vol. 40, no. 5, 302-4.

Mortimer, P.S., 1995, 'Managing Lymphoedema', *Clin & Experiment Derm*, vol. 20, 98-106.

Mortimer, P.S., Sep 1995, 'Evaluation of lymphatic function: abnormal lymph drainage in venous disease', *Int Angiology*, vol. 14, no. 3 (suppl 1), 32-5.

Mortimer, P.S., Jan 2000, 'Implications of the lymphatic system in CVI-associated edema', *Angiology*, vol. 54, no. 1, 3 - 8.

Mortimer, P.S. & Levick, R.J., Sep/Oct 2004, 'Chronic peripheral oedema: The critical role of the lymphatic system', *Clin Med*, vol. 4, no. 5, 448-453

Moseley, A., Piller, N. & Carati, C., 2005, 'The effect of gentle arm exercise and deep breathing on secondary arm lymphoedema', *Lymphology*, vol. 38, no. 3, 136-145.

Moseley, A., Piller, N., Carati, C. & Esterman, A., Jun 2004, 'The Sun Ancon Chi Machine Aerobic Exerciser: a new patient focused, home based therapy for people with chronic secondary leg lymphoedema', *Lymphology*, vol. 37, 53-61.

Moseley, A., Piller, N., Carati, C. & Esterman, A., 2003, 'The impact of the Sun Ancon Chi Machine Aerobic Exerciser on chronic oedema of the legs', *Aus & NZ J Phlebology*, vol. 7, no. 2, 5-10.

Moseley, A., Piller, N. & Caratic, C., 2002, 'Combined opto-electronic perometry and bioimpedance to measure objectively the effectiveness of a new treatment intervention for chronic secondary leg lymphoedema', *Lymphology*, vol. 35, 136-143.

Mulrow, C. & Oxman, A., 1996, 'How to Conduct a Cochrane Systematic Review (3rd Ed)', BMJ Publishing Group, United Kingdom.

Nagata, Y., Murata, R., Mitsumori, M., Okajima, K., Ishigaki, T., Ohya, N., Fujiwara, K., Abe, M. & Kumada, K. Feb 1994, 'Intraarterial infusion of autologous lymphocytes for the treatment of refractory lymphoedema. Preliminary report', *Euro J Surg*, vol. 160, no. 2, 105-9,

Nakaji, S., Shiroto, C., Yodono, M., Umeda, T. & Liu, Q., Feb 2005, 'Retrospective study of adjunctive diode laser therapy for pain attenuation in 662 patients: detailed analysis by questionnaire', *Photomedicine & Las Surg*, vol. 23, no. 1, 60-5.

Neumann, H.A., Jul 1998, 'Compression therapy with medical elastic stockings for venous disease', *Dermatologic Surg*, vol. 24, no. 7, 765-70.

Neumann, H.A. & van den Broek, M.J., Aug 1995, 'A comparative clinical trial of graduated compression stockings and O-(beta-hydroxyethyl)-rutosides (HR) in the treatment of patients with chronic venous insufficiency', *Zeitschrift fur Lymphologie - J Lymphology*, vol. 19, no. 1, 8-11.

Nicolaides, A.N., Jan 2000, 'Edema in chronic venous insufficiency and the effect of modern pharmacology', *Angiology*, vol. 51, no. 1: 1-8.

Nicolaides, A.N., Nov 2000, 'Investigation of chronic venous insufficiency: A consensus statement', *Circulation*, [vol.](#) 102, no. 20, e126-e163.

- Nocker, W., Diebschlag, W. & Lehmacher, W., 1990, 'Clinical trials of the dose-related effects of O-(β -hydroxyethyl)-rutosides in patients with chronic venous insufficiency', *Phlebology*, vol. 5, suppl. 1, 23-26
- Nouri, K., Jimenez, G., Harrison-Balestra, C. & Elgert, G., 2003, '545-nm pulsed dye laser in the treatment of surgical scarring starting on the suture removal day', *Dermatol Surg*, vol. 29, 65-73.
- O'Brien, B.M., Mellow, C.G., Khazanchi, R.K., Dvir, E., Kumar, V. & Pederson, W.C., Apr 1990, 'Long-term results after microlymphaticvenous anastomoses for the treatment of obstructive lymphedema', *Plastic Reconst Surg*, vol. 859, no. 4, 562-72.
- Ogawa, Y., Yoshizumi, M., Kitagawa, T., Kitaichi, T., Katoh, I., Hisaeda, H. & Himeno, K. Dec 1999, 'Investigation of the mechanism of lymphocyte injection therapy in treatment of lymphedema with special emphasis on cell adhesion molecule (L-selectin)', *Lymphology*, vol. 32, no. 4, 151-6.
- Ohkuma, M., Sep 1992, 'Lymphedema treated by microwave and elastic dressing', *Int J Derm*, vol. 31, no. 9, 660-3.
- Ohkuma, M., Jun 2002, 'Treatment of peripheral lymphedema by concomitant application of magnetic fields, vibration and hyperthermia: a preliminary report', *Lymphology*, vol. 35, no. 2, 87-90.
- Olszewski, W.L., 1991 'Lymph pressure and flow in limbs' in 'Lymph stasis: Pathophysiology, diagnosis and treatment', CRC Press, United States of America, 119, 122-125, 130.
- Olszewski, W.L. & Engeset, A., 1998, 'Vasomotoric function of lymphatics and lymph transport in limbs during massage and with elastic support', in *Progress in Lymphology XI*, Partsch, H.(ed) Excerpta Medica, International Congress series 779, Elsevier, Amsterdam, 571-5.
- Olszewski, W., Jan 2000, 'Clinical efficacy of micronized purified flavanoid fraction (MPFF) in edema', *Angiology*, vol. 51, no. 1, 25-29.
- Olszewski, W.L., 2003, 'Pathophysiological aspects of lymphedema of human limbs: I. Lymph protein composition', *Lymphatic Res & Biol*, vol. 1, no. 3, 235-43.

Orsted, H.L., Radke, L. & Gorst, R., Oct 2001, 'The impact of musculoskeletal changes on the dynamics of the calf muscle pump', *Ostomy Wound Manag*, vol. 47, no. 10, 18-24.

Ozaslan, C. and Kuru, B., Jan 2004, 'Lymphedema after treatment of breast cancer', *Amer J Surg*, vol. 187, no. 1, 69-72.

Padberg, F.T. Jr., Johnston, M.V. & Sisto, S.A., Jan 2004, 'Structured exercise improves calf muscle pump function in chronic venous insufficiency: a randomized trial', *J Vasc Surg*, vol. 39, no. 1, 79-87

Papakostas, Y.G. & Daras, M.D., 2001, 'Placebos, placebo effect, and the response to the healing situation: The evolution of a concept', *Epilepsia*, vol. 42, no. 12, 1614-1625.

Pappas, P.J., You, R., Rameshwar, P., Gorti, R., DeFouw, D.O., Phillips, C.K., Padberg, F.T. Jr., Silva, M.B. Jr., Simonian, G.T., Hobson, R.W. 2nd., & Duran, W.N., 1999, 'Dermal tissue fibrosis in patients with chronic venous insufficiency is associated with increased transforming growth factor', *J Vasc Surg*, vol. 30, no. 6, 1129-45.

Partsch, H., 2003, 'Practical aspects of indirect lymphography and lymphoscintigraphy.', *Lymphatic Research & Biology*, vol. 1, no. 1, 71-3.

Pecking, A., Lasry, S., Boudinet, A., et al., 1988, 'Post surgical physio-therapeutic treatment: interest in secondary upper limb lymphoedema prevention', in Partsch, H., (ed)., 'Progress in lymphology – Proceedings of the XIth Congress in Vienna', Elsevier Science, Amsterdam, 561-64.

Pecking, A.P., Fevrier, B., Wargon, C. & Pillion, G., Jan 1997, 'Efficacy of Daflon 500mg in the treatment of lymphedema (Secondary to conventional therapy of breast cancer)', *Angiology*, vol. 48, no. 1, 93-98.

Periera de Godoy, J.M., Braile, D.M., de Fátmima Godoy, M. & Longo, O (Jr)., 2002, 'Quality of life and peripheral lymphedema', *Lymphology*, vol. 35, 72-5.

Perrin, M. & Guex, J.J., Jan 2000, 'Edema and leg volume: Methods of assessment', *Angiology*, vol. 51, no. 1, 9-12.

Petrek, J.A., Senie, R.T., Peters, M. and Rosen, P.P. , Sep 2001, 'Lymphedema in a cohort of breast carcinoma survivors 20 years after diagnosis', *Cancer*, vol. 92, no. 6, 1368-77.

- Phillips, G.W., Paige, J. & Molan, M.P., Jan 1995, 'A comparison of colour duplex ultrasound with venography and varicography in the assessment of varicose veins', *Clin Radiol*, vol. 50, no.1, 20-5.
- Pierson, S., Pierson, D., Swallow, R. & Johnson, G. Jr., Jan 1983, 'Efficacy of graded elastic compression in the lower leg', *JAMA*, vol. 249, no. 1, 242-3.
- Piller, N., 1976, 'Conservative treatment of acute and chronic lymphoedema with benzopyrones', *Lymphology*, vol. 9, no. 4, 132-7.
- Piller, N.B. & Clodius, L., Dec 1976, 'The use of a tissue tonometer as a diagnostic aid in extremity lympho-edema: a determination of its conservative treatment with benzo-pyrones', *Lymphology*, vol. 9, no. 4, 127-32.
- Piller, N.B. & Clodius, L., Jun 1978, 'Lymphoedema of the rabbit ear following partial and complete lymphatic blockade; its effects on fibrotic development, enzyme types and their activity levels', *Brit J Experimental Path*, vol. 59, no. 3, 319-26.
- Piller, N.B., 1990, 'Macrophage and tissue changes in the developmental phases of secondary lymphoedema and during conservative therapy with benzopyrone. *Arch Histol & Cytol*, vol. 53, (suppl), 209-18.
- Piller, N.B., Swedborg, I., Wilking, N. & Jensen, G., 1994, 'Short-term manual lymph drainage treatment and maintenance therapy for post-mastectomy lymphoedema', *Lymphology*, vol. 27, suppl, 589-592.
- Piller, N.B., Packer, R., Coffee, J. & Swagemakers, S., 1996, 'Accepting responsibility for health management: Partner training as an effective means of managing chronic lymphoedema', *Progress in Lymphology*, XV, 266-269.
- Piller, N.B. & Thelander, A., 1996, 'Low level laser therapy: A cost effective treatment to reduce post mastectomy lymphoedema', *Lymphology*, vol. 29, suppl. 1, 297-300.
- Piller, N.B. & Thelander, A., 1998, 'Treatment of chronic postmastectomy lymphedema with low level laser therapy: a 2.5 year follow-up', *Lymphology*, vol. 31, no. 2, 74-86.
- Pissas, A., Dautheville, E., Petricoul, S. et al., 2001, 'Quality of life with lymphoedema patients: which assessment for psychological profile? An original experience: a patients' association in France', *Euro J Lymph*, vol. 9, 74.

Pond, C.M. & Mattacks, C.A., Feb 2002, 'The activation of the adipose tissue associated with lymph nodes during the early stages of an immune response', *Cytokine*, vol. 17, no. 3, 131-9.

Porter, J.M. & Moneta, G.L., 1995, 'International Consensus Committee on Chronic Venous Disease. Reporting standards in venous disease: An update', *J Vasc Surg*, vol. 21, 635-45.

Proby, C.M., Gane, J.N., Joseph, A.E. & Mortimer, P.S., Jun 1990, 'Investigation of the swollen limb with lymphography', *Brit J Derm*, vol. 123, no. 1, 29-37.

Raju, S., Owens, S. & Neglen, P., 2001, 'Reversal of abnormal lymphoscintigraphy after placement of venous stents for correction of associated venous obstruction', *J Vasc Surg*, vol. 34, 779-84.

Raju, S., Owens, S. & Neglen, P., 2002, 'The clinical impact of iliac venous stents in the management of chronic venous insufficiency', *J Vasc Surg*, vol. 35, 8-15.

Ramlett, A.A., Jan 2000, 'Pharmacologic aspects of phlebotropic drug in CVI-associated edema', *Angiology*, vol. 51, no. 1, 19-23.

Ramelet, A., 2000, 'Microcirculation and chronic venous insufficiency-induced trophic disorders', *Medicographia*, vol. 22, no. 3, 139-143.

Recek, C., Sep-Oct 2004, 'The venous reflux', *Angiology*, vol. 55, no. 5, 541-8.

Rehn, D., Golden, G., Nocker, W., Diebschlag, W. & Lehmacher, W., 1993, 'Comparison between efficacy and tolerability of Oxerutins and Troxerutin in the treatment of patients with chronic venous insufficiency', *Arzneim-Forsch./Drug Res*, vol. 43, no. 10, 1060-1063.

Rehn, D., Unkaufm M., Klein, P., Jost, V. & Lucker, P.W., 1996, 'Comparative clinical efficacy and tolerability of Oxerutins and Horse Chestnut Extract in patients with chronic venous insufficiency', *Arzneim-Forsch./Drug Res*, vol. 46, no. 5, 483-487.

Reul-Hirche, H., Piller, N.B. & Watkins, T., July 2001, 'Setting a national standard for measurement of lymphoedematous limbs' *Australasian Lymphology Association Newsletter*, 1:4, 8-12

Rockson, S.G., Mar 2001, 'Lymphedema', *Amer J Med*, vol. 110, no. 4, 288-95.

Rockson, S.G., 2004, 'The elusive adipose connection', *Lymph Res & Biol*, vol. 2, no. 3, 105-106.

Roztocil, K., Pretovsky, I. & Olivia, I., 1993, 'The effects of hydroethylrutosides on capillary filtration rate in the lower limbs of man', *Euro J Clin Pharm*, vol. 11, 435-8.

Ruckley, C., Jan 1997, 'Socioeconomic impact of chronic venous insufficiency and leg ulcers', *Angiology*, vol. 48, no. 1, 67-69.

Sadick, N.S., 1992, 'Predisposing factors of varicose and telangiectatic leg veins', *J Dermatol Surg Oncol*, vol. 18, 883-886.

Sadick, N.S., Jul 2005, 'Advances in the treatment of varicose veins: ambulatory phlebectomy, foam sclerotherapy, endovascular laser, and radiofrequency closure', *Dermatologic Clinics*, vol. 23, no. 3, 443-55.

Safar, H., Shawa, N., Al-Ali, J., Al-Nassar, M., Dashti, H. & Asfar, S., Jan-Feb 2004, 'Is there a need for Doppler vascular examination for the diagnosis of varicose vein? A prospective study', *Med Principles & Prac*, vol. 13, no. 1, 43-6.

Sandel, S.L, Judge, J.O., Landry, N., Faria, L, Ouellette, R. & Majczak, M., 2005, 'Dance and movement program improves quality-of-life measures in breast cancer survivors', *Cancer Nurs*, vol. 28, no. 4, 301-309.

Schad, H., 1996, 'Physiologie der lymphbildung und der Lymphströmung', *Phlebology*, vol. 25, 213-21.

Schmid-Schönbein, G.W., 1990, 'Microlymphatics and lymph flow', *Physiol Rev*, vol. 70, no. 4, 987-1028.

Schreuders, T.A., Roebroek, M.E., Jaquet, J.B., Hovius, S.E. & Stam, H.J., Nov 2004, 'Long-term outcome of muscle strength in ulnar and median nerve injury: comparing manual muscle strength testing, grip and pinch strength dynamometers and a new intrinsic muscle strength dynamometer', *J Rehab Med*, vol. 36, no. 6, 273-8.

Segers, P., Belgrado, J.P., Leduc, A., Leduc, O. & Verdonck, P., Oct 2002, 'Excessive pressure in multichambered cuffs used for sequential compression therapy', *Physical Therapy*, vol. 82, no. 10, 1000-8.

Shields, J., 1980, 'Central lymph propulsion', *Lymphology*, vol. 13, 9–17.

Song, R., Gao, X., Li, S. & Zuo, Z., 1982, 'Surgical treatment of lymphedema of the lower extremity', *Clin Plast Surg*, vol. 9, 113–117.

Shimada, M., Yoshikawa, K., Suganuma, T., Kayanuma, H., Inoue, Y., Ito, K., Senoo, A. & Hayashi, S. Jul-Aug 2003, 'Interstitial magnetic resonance lymphography: comparative animal study of gadofluorine 8 and gadolinium diethylenetriamine-pentaacetic acid', *J Computer Assist Tomography*, vol. 27, no. 4, 641-6.

Spence, R.K. & Cahall, E., Nov 1996, 'Inelastic versus elastic leg compression in chronic venous insufficiency: a comparison of limb size and venous hemodynamics.', *J Vasc Surg*, vol. 24, no. 5, 783-7.

Staffa, R., 2002, 'Chronic venous insufficiency-epidemiology', *Bratislavske Lekarske Listy*, vol. 103, no. 4-5, 166-8.

Stanton, A., Northfield, J., Holroyd, B., Mortimer, P.S. & Levick, J.R., 1997, 'Validation of an optoelectronic limb volumeter (perometer)', *Lymphology*, vol. 30, no. 2, 77-97.

Stanton, A.W.B., Badger, C. & Sitzia, J., 2000, 'Non-invasive assessment of the lymphedematous limb', *Lymphology*, vol. 33, 122-35.

Stanton, A.W.B., Svensson, W.E., Mellor, R.H., Peters, A.M., Levick, J.R. & Mortimer, P.S., 2001, 'Differences in lymph drainage between swollen and non-swollen regions in arms with breast-cancer-related lymphoedema', *Clinical Science*, vol. 101, 131-140.

Stemmer, R., 1976, 'Ein Klinisches Zeichen zur Frü- und Differentialdiagnose des Lymphödems', *VASA*, vol 5, 262.

Strandness, D.E., 1976 'Applied venous physiology in normal subjects and venous insufficiency', In *Venous Problems*, Bergan, J.J., Yao, J.S.T., (Eds), Year Book, Chicago, 24-45.

Strandness, D.E., 1987, 'Vascular Disease of the Extremities' in '*Harrison's Principles of Internal Medicine (11th ED)*', Braunwald, E. et al., (eds), McGraw-Hill Book Company, New York, 1040-1046.

Strössenreuther, R.H.K., 2003, 'Compression Therapy' in *Textbook of Lymphology for Physicians and Lymphedema Therapists*, Földi, M., Földi, E. & Kubik, S., (eds), Elsevier GmbH, Germany, 532-35.

Sumner, D.S., 1995, 'Hemodynamics and Pathophysiology of Venous Disease' in Ruthford, R.B. (ed), 'Vascular Surgery (4th Ed)', WB Saunders, Philadelphia, 1673-98.

Surakka, J., Romberg, A., Ruutiainen, J., Virtanen, A., Aunola, S. & Maentaka, K., Sep 2004, 'Assessment of muscle strength and motor fatigue with a knee dynamometer in subjects with multiple sclerosis: a new fatigue index', *Clin Rehab*, vol. 18, no. 6, 652-9.

Svensson, W.E., Mortimer, P.S., Tohno, E. et al., 1990, 'Increased arterial inflow demonstrated by Doppler ultrasound in arm swelling following breast cancer treatment', *Euro J Cancer*, vol. 30A, no. 5, 661-4.

Swedborg, I., 1980, 'Effectiveness of combined methods of physiotherapy for post-mastectomy lymphoedema', *Scand J Rehab Med*, vol. 12, 77-85

Swedborg, I., 1984, 'Effects of treatment with an elastic sleeve and intermittent pneumatic compression in post-mastectomy patients with lymphoedema of the arm', *Scand J Rehab Med*, vol. 16, 35-41.

Swedborg, I., Norrefalk, J., Piller, N.B. & Asard, C., 1993, 'Lymphoedema post-mastectomy: is elevation alone an effective treatment?', *Scand J Rehab Med*, vol. 25, 79-82.

Szolnok, G., Lakatos, B., Keskeny, T. & Dobozy, A., 2002, 'Advantage of combined decongestive lymphatic therapy over manual lymph drainage: A pilot study', *Lymphology*, vol. 35, suppl 1, 277-282.

Szuba, A. & Rockson, S.G., Nov 1997, 'Lymphedema: anatomy, physiology and pathogenesis', *Vasc Med*, vol. 2, no. 4, 321-6.

Szuba, A., Cooke, J.P., Yousuf, S. & Rockson, S.G., Sep 2000, 'Decongestive Lymphatic Therapy for Patients with Cancer-related or Primary Lymphedema', *Cancer*, vol. 109, no. 4

Szuba, A., Achalu, R. & Rockson, S.G., Dec 2002, 'Decongestive lymphatic therapy for patients with breast carcinoma-associated lymphedema. A randomized, prospective study of a role for adjunctive intermittent pneumatic compression', *Cancer*, vol. 95, no. 11, 2260-2267.

Tierney, S., Aslam, N., Rennie, K. & Grace, P., 1996, 'Infrared optoelectronic volumetry, the ideal way to measure limb volume', *Euro J Vasc Endovasc Surg*, vol. 12, 4, 412-7.

Tisi, P.V. & Beverley, C.A., 2002, 'Injection sclerotherapy for varicose veins (Cochrane Review)', *Cochrane Database Systematic Review*, (1): CD001732.

Tiwari, A., Cheng, K.S., Button, M., Myint, F. & Hamilton, G., Feb 2003, 'Differential diagnosis, investigation, and current treatment of lower limb lymphedema', *Arch Surg*, vol. 138, no. 2, 152-161.

Turner, J., Hayes S. & Reul-Hirche, H., Jun 2004, 'Improving the physical status and quality of life of women treated for breast cancer: a pilot study of a structured exercise intervention', *J Surg Oncol*, vol. 86, no. 3, 141-6.

Unkauf, M., Rehn, D., Klinger, J., de la Motte, S. & Grossmann, K., 1996, 'Investigation of the efficacy of Oxerutins compared to placebo in patients with chronic venous insufficiency treated with compression stockings', *Arzneim.-Forsch/Drug Res*, vol. 46, no. 5, 478 – 482.

Van Bemmelen, P.S., Bedford, G., Beach, K. & Strandness, D.E., 1989, 'Quantitative segmental evaluation of venous valvular reflux with duplex ultrasound scanning', *J Vasc Surg*, vol. 10, no. 425-31.

Van Geest, A.J., Veraart, J.C., Nelemans, P. & Neumann, H., Mar 2000, 'The effect of medical elastic compression stockings with different slope values on edema', *Derm Surg*, vol. 26, no. 3, 244-47.

Van Haarst, E.P., Liasis, N., Van Ramshorst, B. & Moll, F.L., Oct 1996, 'The development of valvular incompetence after deep vein thrombosis: a 7 year follow-up study with duplex scanning.', *Euro J Vasc & Endovasc Surg*, vol. 12, no. 3, 295-9.

Van Rij, A.M., Solomon, C. & Christie, R., Nov 1994, 'Anatomic and physiologic characteristics of venous ulceration', *J Vasc Surg*, vol. 20, no. 5, 759-64.

Vanscheidt, W., Rabe, E., Naser-Hijazi, B., Ramelet, A.A., Partsch, H., Diehm, C., Schultze-Ehrenburg, U., Spengel, F., Wirsching, M., Gotz, V., Schnitzer, J. & Henneicke-von Zeplin, HH., 2002, 'The efficacy and safety of a coumarin-/troxerutin-combination (SB-LOT) in patients with chronic venous insufficiency: A double blind placebo controlled randomised study', *VASA*, vol. 31, 185-190.

Varma, S. & Pappas, P.J. 2004, 'The Venous System', in *Vascular Nursing (4th Ed)*, Fahey, V.A., (Ed), Elsevier, USA, 21-31.

Vignes, S., Boursier, V., Priollet, P., Miserey, G. & Trevidic, P., Feb 2003, 'Quantitative evaluation and qualitative results of surgical lymphovenous anastomosis in lower limb lymphedema', *J des Maladies Vasculaires*, vol. 28, no. 1, 30-5.

Villavicencio, J.L., Conaway, C.W., Coffey, J.A., Gomez, E.R., Salander, J.M. & Rich, N.M., 1989, 'New Concepts and Surgical Approaches to Chronic Venous Insufficiency in Current Critical Problems', in *Vascular Surgery*, Veith, F. (Ed), Quality Medical Publishing Inc, USA, 119-124.

Villavicencio, J. L., 2001, 'Sclerotherapy guidelines' in *Handbook of venous disorders (2nd Ed)*, Gloviczki, P. and Yao, J.S.T. (Eds), Arnold, London, 253-266.

Wadworth, A.N. & Faulds D., 1992, 'Hydroxyethylrutosides, a review of its pharmacology, and therapeutic efficacy in venous insufficiency and related disorders', *Drugs*, vol. 44, no. 6, 1013-1032.

Watanabe, T., Owashi, K., Kanauchi, Y., Mura, N., Takahara, M. & Ogino, T., May 2005, 'The short-term reliability of grip strength measurement and the effects of posture and grip span', *Amer J Hand Surg*, vol. 30, no. 3, 603-9.

Watanabe, R., Miura, A., Inoue, K., Haeno, M., Sakamoto, K. & Kanai, H., 1989, 'Evaluation of leg edema using a multifrequency impedance meter in patients with lymphatic obstruction', *Lymphology*, vol. 22, 85-92.

Ward, L., Bunce, I., Cornish, B., Mirolo, B.R., Thomas, B.J. & Jones, L.C., 1992, 'Multi-frequency bioelectrical impedance augments the diagnosis and management of lymphoedema in post-mastectomy patients', *Euro J Clin Invest*, vol. 22, 751-54.

Ward, L.C., Byrne, N.M., Rutter, K., Hennoste, L., Hills, A.P., Cornish, B.H. & Thomas, B.J., 1997, 'Reliability of multiple frequency bioelectrical impedance analysis: an inter-machine comparison', *Am J Human Biol*, vol. 9, no. 1, 63-72.

Weber, J., Jun 2001, 'Phlebological diagnosis. Phlebography of the veins of the lower extremity', *Zentralblatt fur Chirurgie*, vol. 126, no. 6, 466-71.

Weiss, J.M. & Spray, B.J., 2002, 'The effect of complete decongestive therapy on the quality of life of patients with peripheral lymphedema', *Lymphology*, vol. 35, 46-58.

Weissleder, H. & Schuchhardt, C., 2000, 'Anatomy (fundamentals)', in *Lymphoedema Diagnosis and Treatment*, Weissleder, H. & Schuchhardt, C. (Eds), Wesel, Baden-Baden, chp1.

Welch, H.J., Young, C.M., Semegran, A.B., Iafrati, M.D., Mackey, W.C. & O'Donnell, T.F. Jr., Nov.1996 , 'Duplex assessment of venous reflux and chronic venous insufficiency: the significance of deep venous reflux', *J Vasc Surg*, vol. 24, no. 5, 755-62.

Williams, A., Franks, P.J. & Moffatt, C.J., 2005, 'Lymphoedema: estimating the size of the problem', *Pall Med*, vol. 19, no. 4, 300-13.

Williams, A.F., Vadgama, A., Franks, P.J. & Mortimer, P.S., 2002, 'A randomized controlled cross-over study of manual lymphatic drainage therapy in women with breast cancer-related lymphedema', *Euro J Cancer Care*, vol. 11, no. 5, 254-263.

Witte, C.L. & Witte, M.H., 'Diagnostic and interventional imaging of lymphatic disorders.', Mar 1999, *Int Angiology*, vol. 18, no. 1, 25-30.

Wozniowski, M., Jasinski, R., Pilch, U. & Dabrowska, G., 2001, 'Complex physical therapy for lymphoedema of the limbs', *Physiotherapy*, vol. 87, no. 5, 252-256.

Yamazaki, Z., Idezuki, Y., Nemoto, T. & Togawa, T., Feb 1988, 'Clinical experiences using pneumatic massage therapy for oedematous limbs over the last 10 years', *Angiology*, vol. 39, no. 2, 154-63.

Yang, D., Vandongen, Y.K. & Stacey, M.C. March 1999, 'Effect of exercise on calf muscle pump function in patients with chronic venous disease', *British J Surg*, vol. 86, no. 3, 338-341

Yasuhara, H., Shigematsu, H. & Muto, T., 1996, 'A study of the advantages of elastic stockings for leg lymphoedema', *Int Angiology*, vol. 15, 272-7.

Xia, Z.D, Hu, D., Wilson, J.M., Cherry, G.W. & Ryan, T.J., Apr 2004, 'How echographic image analysis of venous oedema reveals the benefits of leg elevation', *J Wound Care*, vol. 13, no. 4, 125-8.

Zelikovski, A., Melamed, I., Kott, I., Manoach, M. & Urca, I., 1980, 'The "Lymphapress" - A new pneumatic device for the treatment of lymphedema: Clinical trial and results', *Folia Angiologica*, vol. XXV VIII, 165-9.